

## 521 CMR 26.00: DOORS AND DOORWAYS

## 26.1 GENERAL

All doors and openings along *accessible routes* shall comply with the following requirements.

26.1.1 Gates, including ticket gates, shall also comply with 521 CMR 26.00.

Exceptions: Openings greater than 24 inches (24" = 610mm) in depth are not doorways but may be part of an *accessible route*, in which case they shall comply with **521 CMR 20.00: ACCESSIBLE ROUTES** and **521 CMR 24.00: RAMPS** (See **Fig. 26a**). Doors not requiring full user passage, such as shallow closets, may have the *clear* opening reduced to 20 inches (20" = 508mm) minimum, See **521 CMR 9.5.8, Closets**.

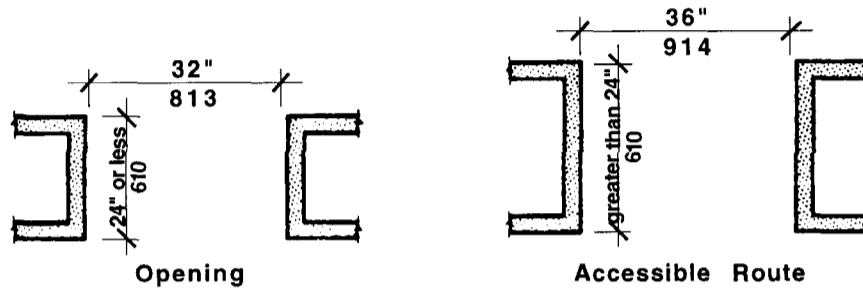

Openings and Accessible Routes  
Figure 26a

26.1.2 In buildings classified in the assembly use and educational use (See **780 CMR 302.0**) with an occupancy of over 150 (See **521 CMR 14.1.1**), all required egress doors which lead directly to the outside at grade, shall be made accessible at the exterior as well as the interior so as to provide a safe path of travel to a public way for persons who are disabled. Such egress doors shall be provided with illuminated signage identifying accessibility by the use of the international symbol contained within the "exit" sign (See **521 CMR 41.1.3**)

## 26.2 REVOLVING DOORS

Revolving doors shall not be the only means of passage at an *accessible entrance* or along an *accessible route* unless the revolving door is also *accessible*. An *accessible* door shall be provided adjacent to a revolving door and shall permit the same use pattern.

26.2.1 Whenever the revolving doors are unlocked, the adjacent *accessible* door shall be unlocked.

26.2.2 The adjacent *accessible* door must have hardware that allows *entrance* into the building as well as *egress*.

## 26.3 TURNSTILES

Turnstiles shall not be the only means of passage at an *accessible entrance* or along an *accessible route*. An *accessible* gate shall be provided adjacent to the turnstile and shall be designed to permit the same use pattern, complying with **521 CMR 26.2.1** and **26.2.2**.

## 26.4 DOUBLE-LEAF DOORWAYS

A doorway having two independently operated door leaves shall have at least one leaf that meets the requirements of **521 CMR 26.5, Width** and **521 CMR 26.6, Maneuvering Clearance**. That leaf shall be an active leaf.

## 26.5 WIDTH

All doorways and openings that are required to be *accessible* shall have a *clear* opening of not less than 32 inches (32" = 813mm). *Clear* opening of a door is measured from the face of the stop on the latch side to the face of the door when the door is open 90 degrees. For door types such as bifold, accordion, and pocket, the *clear* opening is measured when the door is in its most fully open position. See **Fig. 26b** and **26c**.

26.00: continued

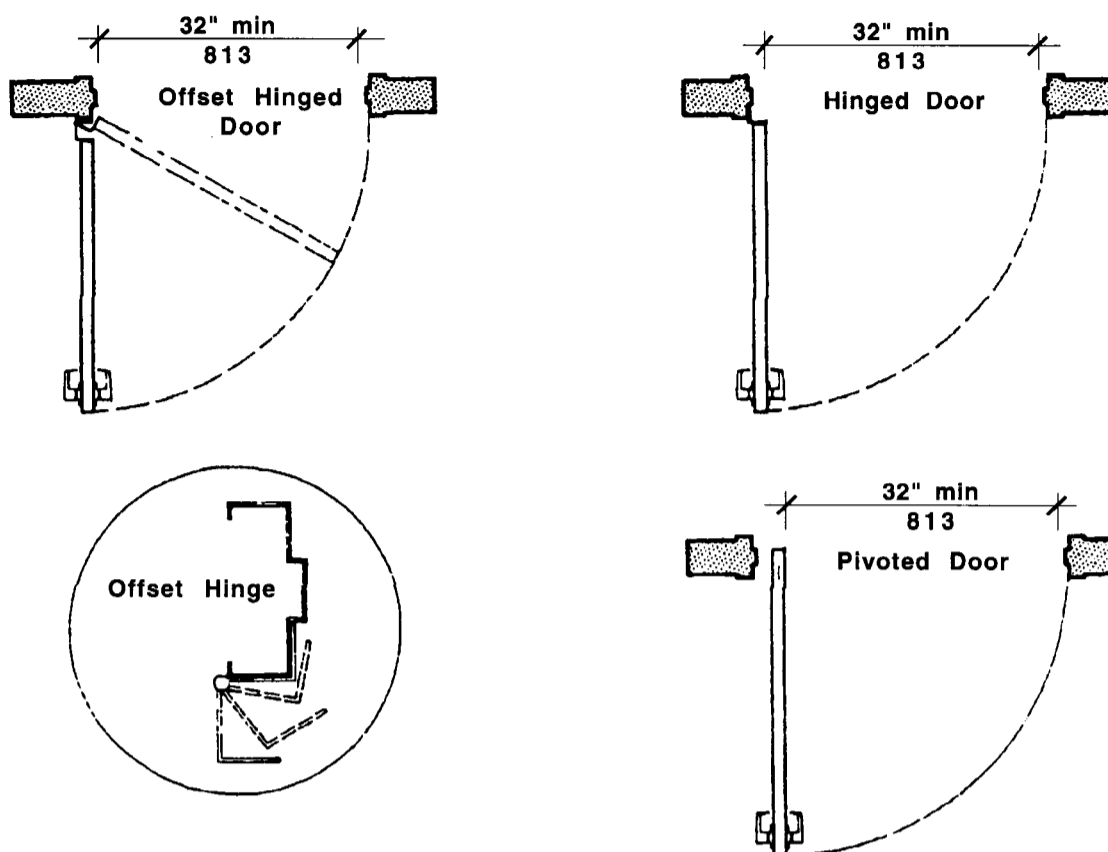

Clear Opening  
Figure 26b

NOTE: A standard 36 inch (36" = 914mm) door with a standard hinge, will produce a *clear* opening of at least 32 inches (32" = 813mm).

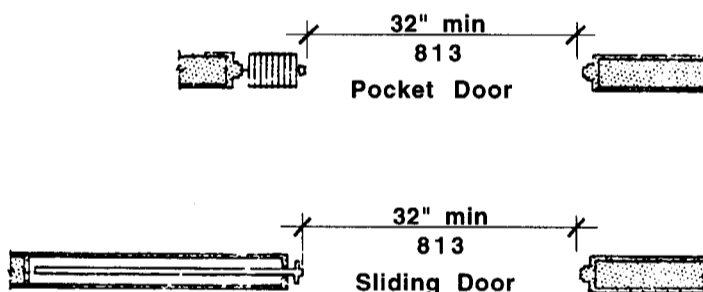

Clear Opening - sliding doors  
Figure 26c

**26.6 MANEUVERING CLEARANCE**

A minimum *clear* floor area shall be provided on both sides of all doors and gates.

Exception: Doors equipped with automatic opening devices are exempt from 521 CMR 26.6.3, 26.6.4 and 26.8

- 26.6.1 The floor or ground area within the required clearances shall be *level*.
- 26.6.2 Doors located in a recess of more than six inches (6" = 152mm) deep shall have clear floor space as required in **521 CMR 26.6.3** and **521 CMR 26.6.4**. Said clear floor space shall be measured within six inches of the door.
- 26.6.3 Pull side clearance shall comply with the following:
  - a. A minimum of 18 inches (18" = 457mm) of *clear* floor space shall be provided on the latch, pull side of the door when the *clear floor space* in front of the door is a minimum of 60 inches (60" = 1524mm). See **Fig. 26d**.

26.00: continued

- b. A minimum of 42 inches (42" = 10667mm) of *clear floor space* shall be provided on the latch, pull side of the door when the *clear floor space* in front of the door is more than 54 inches (54" = 1372mm) but less than 60 inches (60" = 1524mm). See **Fig. 26g**.
- c. A minimum of 24 inches (24" = 610mm) of clear floor space shall be provided on the latch, pull side of the door when the clear floor space in front of the door is a minimum of 54 inches (54" = 1372mm) and the door has a closer. See **Fig. 26d**.

Pull side clearance shall comply with **Fig. 26d**.

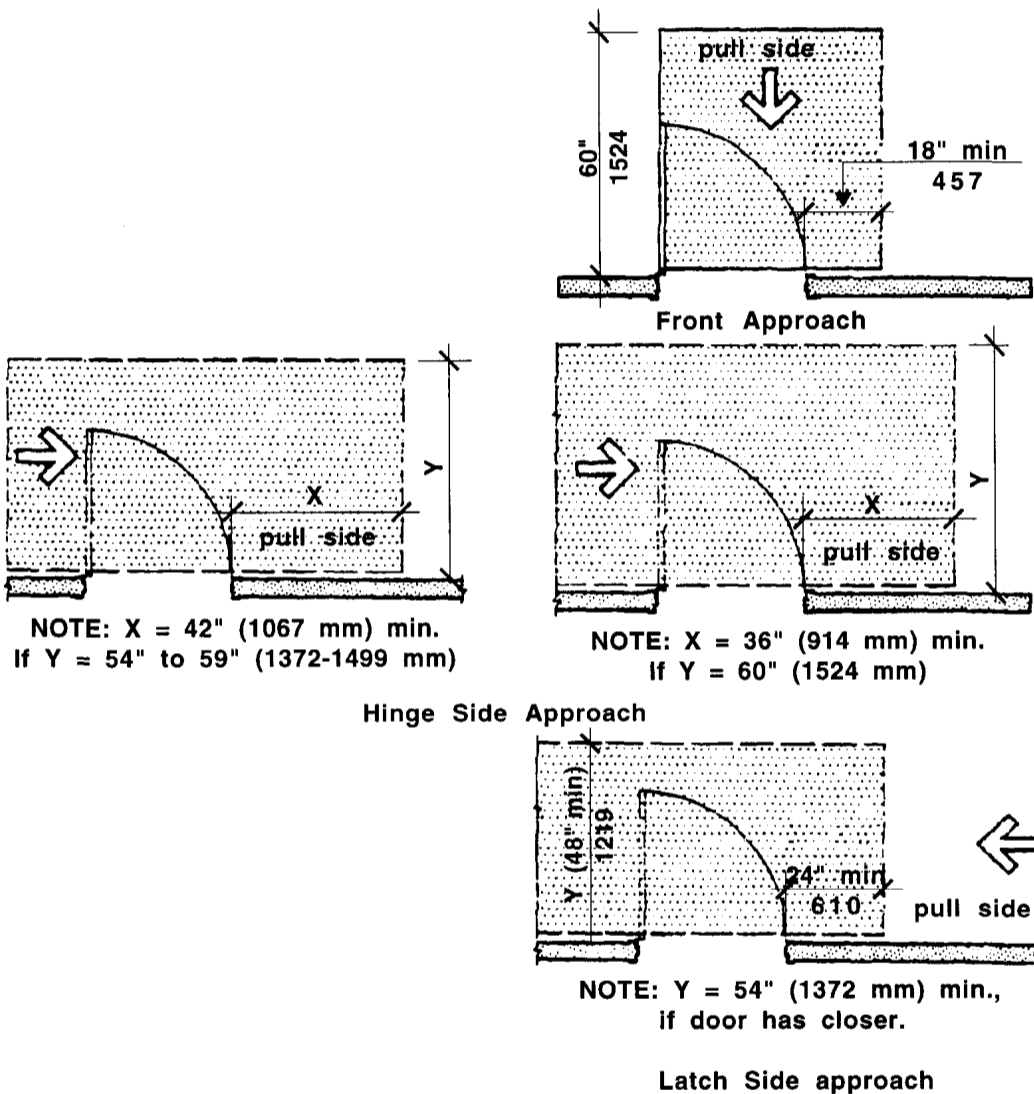

Maneuvering Clearance at Doors (Pull Side)  
Figure 26d

26.00: continued

26.6.4 Push side clearance shall comply with Fig. 26e.

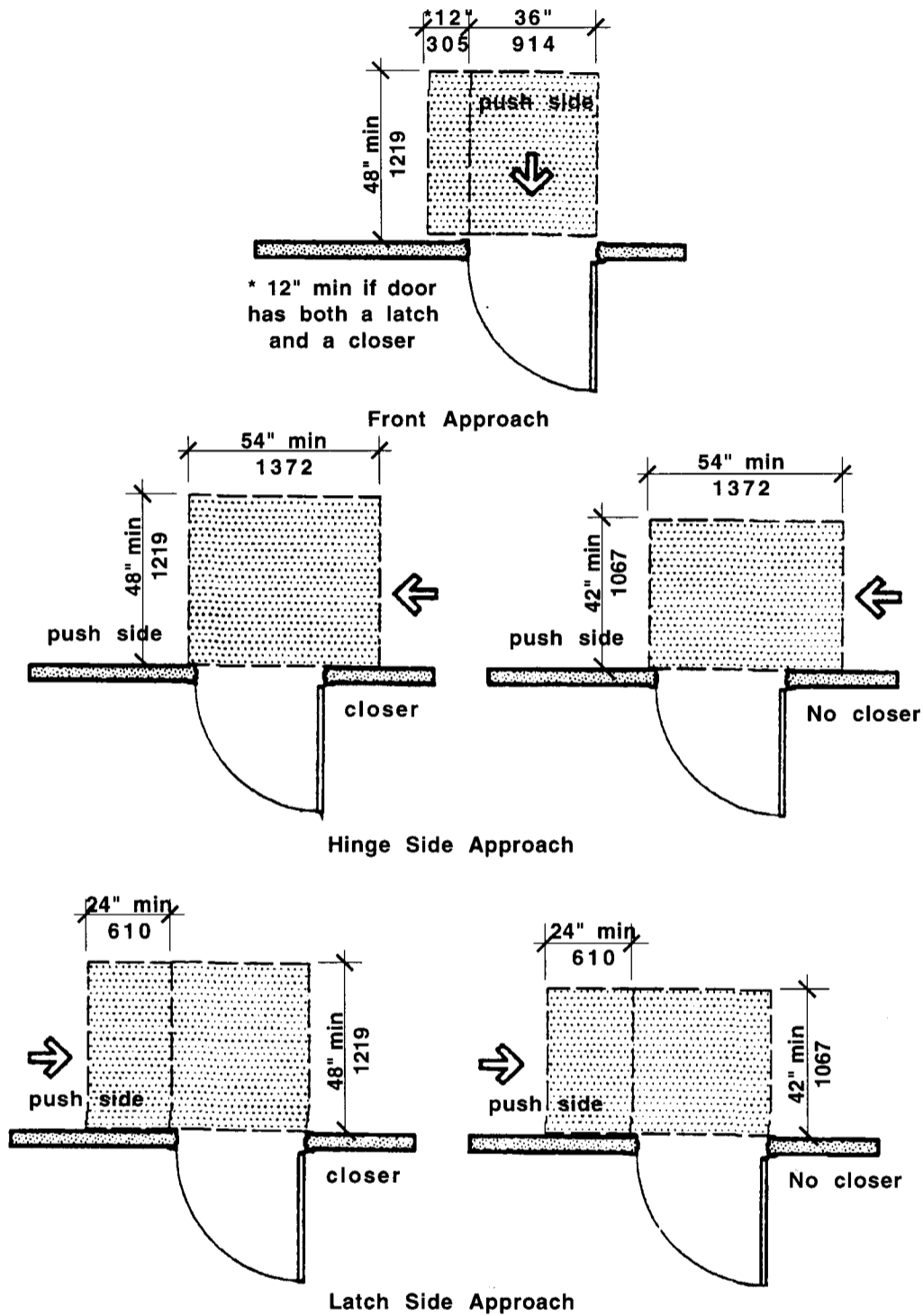

Maneuvering Clearance at Doors (Push Side)  
Figure 26e

26.00: continued

26.6.5 Clearance for sliding door shall comply with **Fig. 26f**.

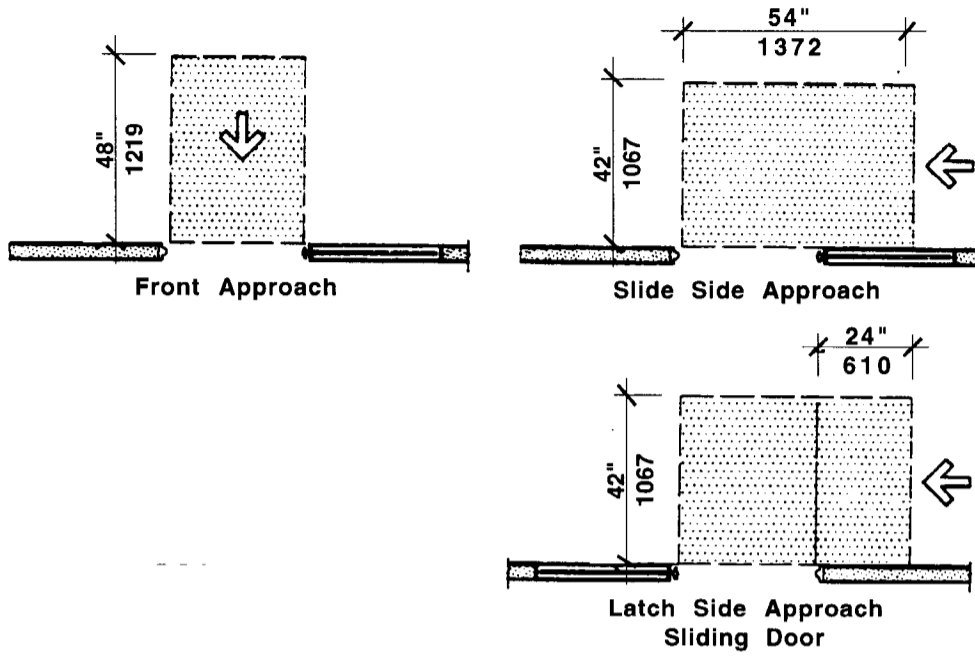

**Maneuvering Clearances at Sliding Doors**  
Figure 26f

**26.6 MANEUVERING CLEARANCE**

A minimum *clear* floor area shall be provided on both sides of all doors and gates:

Exception: Doors equipped with automatic opening devices are exempt from **521 CMR 26.6.3, 26.6.4 and 26.8**

**26.7 TWO DOORS IN SERIES**

The minimum *space* between two hinged or pivoted doors in series shall be 48 inches (48" = 1219mm) plus the width of any door swinging into the *space*. Doors in series shall swing either in the same direction or away from the *space* between the doors. See **Fig. 26g**.

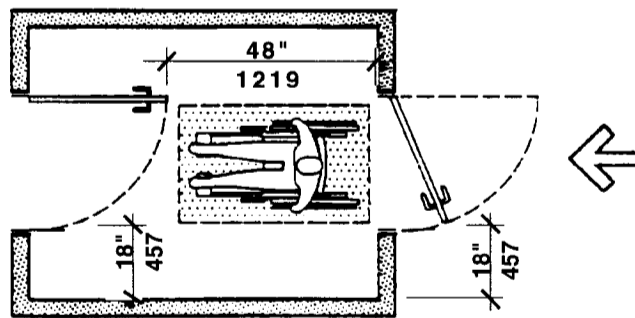

**Vestibule Clearances**  
Figure 26g

**26.8 DOOR OPENING FORCE**

The maximum force for pushing or pulling open a door shall be as follows:

26.8.1 Doors: These forces apply only to opening the door, not to the effort required to retract latch bolts or disengage other devices that may hold the door in a closed position.

- a. exterior hinged doors: 15 lbs.
- b. interior hinged doors: five lbs.
- c. sliding or folding doors: five lbs.

26.00: continued

Exception: Fire doors shall have the minimum opening force allowable by the appropriate *administrative authority*.

26.8.2 Compensating devices: Doors requiring greater force shall be equipped with compensating devices to reduce the operating force, or shall be equipped with automatic opening devices.

### 26.9 DOOR CLOSERS

If a door has a closer, then the sweep period of the closer shall be adjusted so that from an open position of 90 degrees, the door will take at least six seconds to close.

### 26.10 THRESHOLDS

Thresholds at doorways shall comply with the following (See **Fig. 26h**):

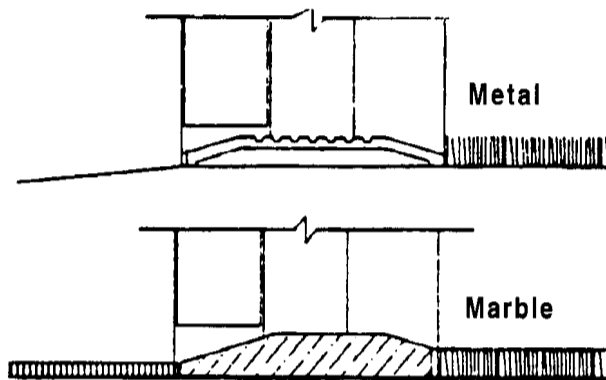

Thresholds  
Figure 26h

26.10.1 Thresholds shall not exceed  $\frac{1}{2}$  inch ( $\frac{1}{2}$ " = 13mm) in height and shall be beveled on both sides with a slope no greater than one-in-two (1:2) (50%).

26.10.2 Changes in floor finish materials shall have an edge strip or threshold that is beveled at a ratio of one-in-two (1:2) (50%).

26.10.3 Exterior sliding door thresholds shall not exceed  $\frac{3}{4}$  of an inch ( $\frac{3}{4}$ " = 19mm) in height and shall be beveled both sides with a slope no greater than one-in-four (1:4) (25%).

### 26.11 DOOR HARDWARE

Shall comply with the following:

26.11.1 Type: Handles, pulls, latches, locks, and other operating devices on *accessible* doors shall have a shape that is easy to operate with one hand and that does not require tight grasping, tight pinching, or twisting of the wrist to operate. Lever-operated mechanisms, push-type mechanisms, and U-shaped handles are acceptable designs. When sliding doors are fully open, operating hardware shall be exposed and usable from both sides.

26.11.2 Height: Hand-operated door opening hardware shall be located 36 inches to 48 inches (36" to 48" = 914mm to 1219mm) above the floor. See **Fig. 26i**

26.11.3 Operation: Doors in the *means of egress* shall be operable with one hand and with a single effort. Doors in the paths of ingress shall be able to be unlocked and opened with one hand.

26.00: continued

26.11.4 Special hardware: Doors opening into hazardous areas shall have door-opening hardware which is knurled or has a roughened surface to give tactile warning to persons with visual impairments. Hazardous areas shall include but not be limited to loading platforms, boiler rooms, and electrical equipment rooms.

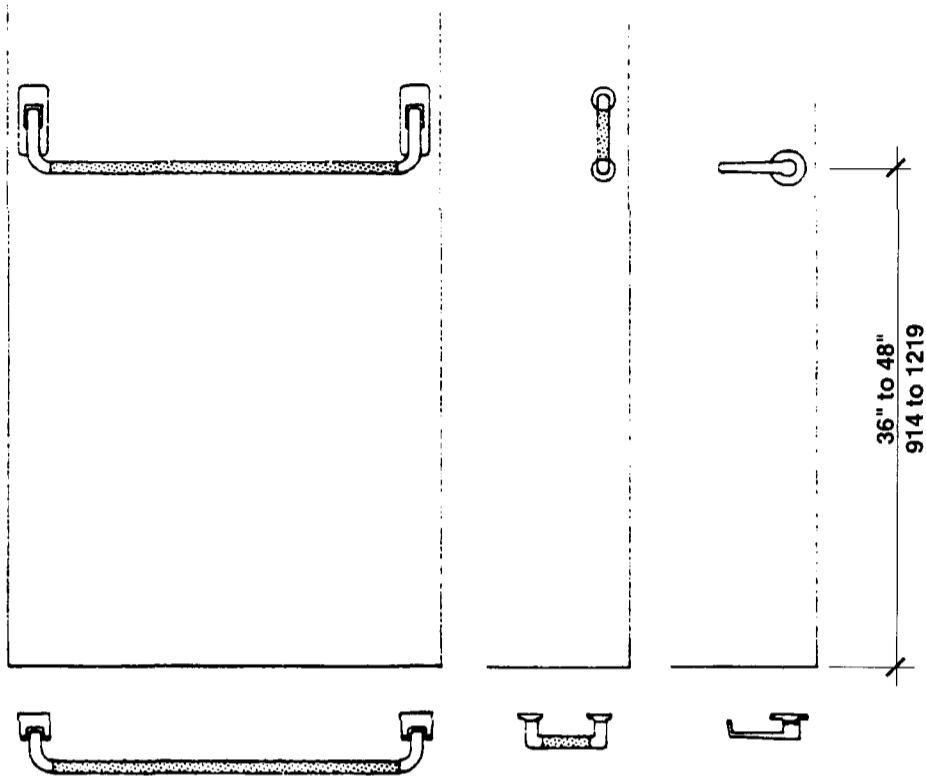

Door Hardware  
Figure 26i