

521 CMR 28.00: **ELEVATORS**

28.1 **GENERAL**

In all multi-story *buildings* and *facilities*, each level including *mezzanines*, shall be served by a passenger elevator. If more than one elevator is provided, each passenger elevator shall comply with 521 CMR 28. *Accessible* elevators shall be on an *accessible route* and located within the *space* with which it is intended to serve. **Elevators are not required under the following exceptions.**

- a. Buildings having only two *levels* may provide an interior *accessible ramp* complying with **521 CMR 24.00: RAMPS** in lieu of an elevator.
- b. *Buildings* having only two levels, in which each *level* serves an unrelated use and in which there is no internal stair, do not require an elevator if each level is *accessible*.
- c. Freight elevators shall not be required to meet the requirements of **521 CMR 28.00** unless the only elevators provided are used as combination passenger and freight elevators for the public and employees.
- d. Elevator pits, elevator penthouses, mechanical rooms, and piping or equipment catwalks shall not be required to meet the requirements for elevator access.
- e. Where platform lifts are allowed to be installed in lieu of an elevator as per **521 CMR 28.12, Wheelchair Lifts/Limited Use Elevators**.
- f. *Multiple dwellings* where all *accessible* rooms and all public use and *common use* spaces are on the *accessible level*.
- g. *Transient lodging facilities* of less than three stories in height and where all *accessible* rooms and all public and *common use* spaces are on the *accessible level*.

28.1.2 The elevator exceptions set forth above do not obviate or limit in any way the obligation to comply with the other accessibility requirements of 521 CMR. For example, floors above or below the *accessible ground floor* must meet the requirements of 521 CMR except for elevator service. If toilet or bathing facilities are provided on a level not served by an elevator, then toilet or bathing facilities must be provided on the *accessible ground floor*.

28.1.3 A passenger elevator that provides service from a garage to only one level of a *building* or *facility* is not required to serve other levels.

28.2 **OPERATION**

Elevator operation shall be automatic.

28.2.1 Self Leveling: Each car shall be equipped with a self-leveling feature that is automatic and independent of the operating device and shall correct any overtravel or undertravel.

28.2.2 The self-leveling feature shall bring the car to a position level with floor landings under all loading conditions from zero to the rated limit. A tolerance of ½ inch (½" = 13mm) shall be permitted.

28.00: **ELEVATORS**

28.3 **HALL CALL BUTTONS**

Shall comply with the following:

28.3.1 Call buttons in elevator lobbies and halls shall be centered at 42 inches (42" = 1067mm) above the floor. See **Fig. 28a**.

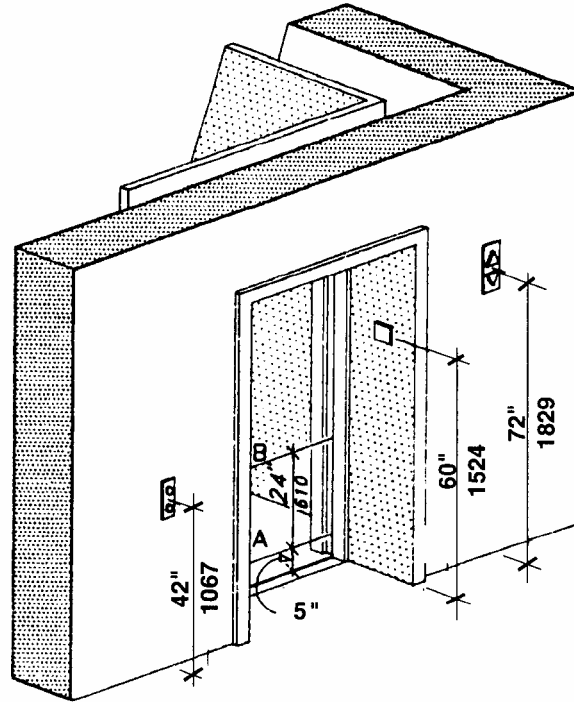

**Hall Buttons
Figure 28a**

28.3.2 Such call buttons shall have visual signals to indicate when each call is registered and when each call is answered.

28.3.3 Call buttons shall be a minimum of $\frac{3}{4}$ of an inch ($\frac{3}{4}$ " = 19mm) in the smallest dimension. The button designating the up direction shall be on top. Buttons shall be raised or flush.

28.3.4 Objects mounted beneath hall call buttons shall not project into the elevator lobby more than four inches (4" = 102mm).

Note: The automatic door reopening device is activated if an object passes through either line A or line B. Line A and line B represent the vertical locations of the door reopening device not requiring contact.

28.4 **HALL LANTERNS**

A visible and audible signal shall be provided at each hoistway *entrance* to indicate which car is answering a call. Lanterns shall comply with the following:

28.00: **ELEVATORS**

28.4.1 Hall lantern fixtures shall be mounted so that their centerline is at least 72 inches (72" = 1829mm) above the lobby floor. *See Fig. 28a.*

28.4.2 Audible signals shall sound once for the up direction and twice for the down direction or shall have verbal annunciators that say "up" and "down."

28.4.3 Visible signals shall have the following features:

- a. Visual elements shall be at least 2½ inches (2½" = 64mm) in the smallest dimension.
- b. Signals shall be visible from the vicinity of the hall call button. *See Fig. 28a.* In-car lanterns located in cars, visible from the vicinity of hall call buttons, and conforming to the above requirements, shall be acceptable.

28.5 **DOOR JAMB MARKINGS**

Both jambs of all elevator hoistway *entrances* shall have raised and *Braille* floor designation jambs that are visible from within the car and the elevator lobby.

28.5.1 The centerline of the characters shall be 60 inches (60" = 1524mm) above finish floor. *See Fig. 28a.*

28.5.2 Such characters shall be two inches (2" = 51mm) high and on a contrasting color background.

28.5.3 Permanently applied plates are acceptable if they are secured to the jambs.

28.6 **DOORS**

Elevator doors shall open and close automatically and shall comply with the following:

28.6.1 Width: Elevator doors shall provide a clear opening that is at least 32 inches (32" = 813mm) wide.

28.6.2 Closing Speed: Doors shall close at a maximum speed of approximately one foot (1' = 305mm) per second.

28.6.3 Reopening Device: A door reopening device shall be provided that will stop and reopen a car door and an adjacent hoistway door automatically if the car door becomes obstructed by an object or person while closing.

- a. The device shall be capable of completing these operations without requiring contact with the obstruction.
- b. The reopening device shall detect possible obstructions passing through the opening at heights of five inches and of 29 inches (5" = 127mm and 29" = 737mm) above finish floor. *See Fig. 28a.*

28.00: **ELEVATORS**

- c. Door reopening devices shall remain effective for at least 20 seconds. After such an interval, doors may close in accordance with the requirements of ASME A17.1-1990 and, if applicable, with 524 CMR: the Board of Elevator Regulations.

28.6.4 Door and Signal Timing for Hall Calls: Doors and signals shall be coordinated to comply with the following:

- a. The minimum acceptable time from notification that a car is answering a call until the doors of that car start to close shall be calculated from the following equation:

$$T = D/(1.5 \text{ ft/s})$$

or

$$T = D/(457 \text{ mm/s})$$

T = total time in seconds

D = distance (in feet or millimeters) from a point in the lobby or corridor 60 inches (60" = 1524mm) directly in front of the farthest call button controlling that car to the centerline of its hoistway door. See **Fig. 28b**.

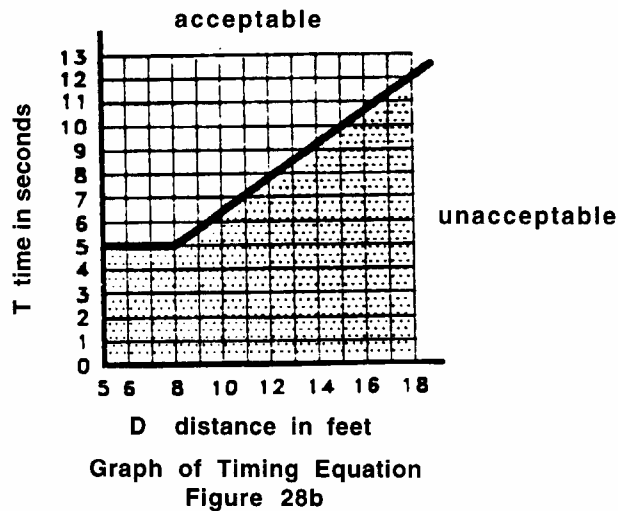

For cars with in-car lanterns, "T" begins when the lantern is visible from the vicinity of hall call buttons and an audible signal is sounded.

- b. The minimum acceptable notification time shall be five seconds.

28.00: **ELEVATORS**

28.6.5 Door Delay for Car Calls: The minimum time for elevator doors to remain fully open in response to a car call shall be three seconds.

28.7 **ELEVATOR CAR**

The elevator cab shall be a minimum of 54 inches by 68 inches (54" x 68" = 1372mm x 1727mm) measured wall-to-wall and wall-to-door, or may be 60 inches by 60 inches, (60" by 60" = 1524mm by 1524mm) wall-to-wall and wall to wall. The door can be located on any wall or walls.

Exception: In existing *buildings*, where existing shaft configuration prohibits strict compliance with **521 CMR 28.7**, the maximum car size allowable for the existing shaft shall be provided, but in no case shall the inside car area be smaller than 48 inches by 48 inches, wall-to-wall and wall-to-door.

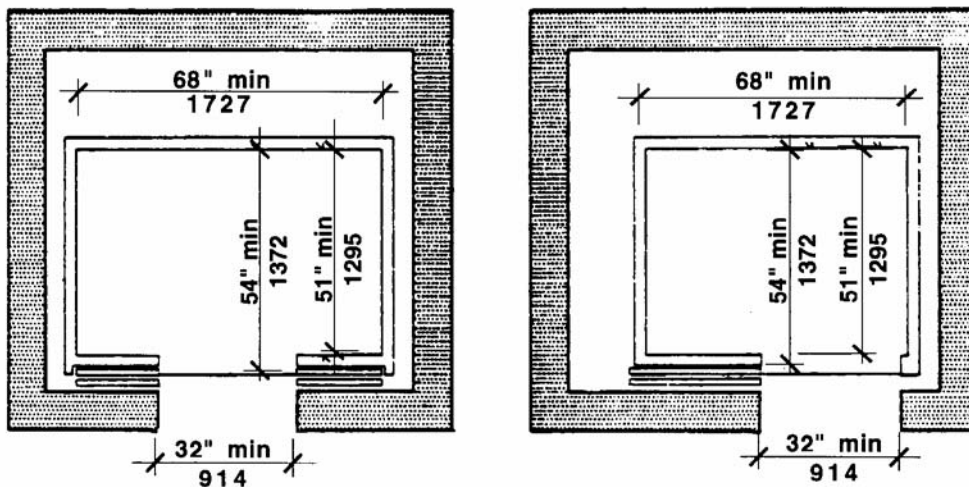

Minimum Elevator Cab Size
Figure 28c

28.7.1 Hoistway Clearance: The horizontal clearance between the car platform sill and the edge of any hoistway landing shall be no greater than 1¼ inch (1¼" = 32mm).

28.7.2 Handrails shall be located on at least one wall in every elevator between 32 and 36 inches (32" and 36" = 813mm and 914mm) above the car floor, with a 1½ inch (1½" = 38mm) clearance from the wall.

28.7.3 Floor surface: Floor surfaces shall comply with **521 CMR 29.00: FLOOR SURFACES**.

28.00: ELEVATORS

28.8 CAR CONTROLS

Elevator control panels shall have the following features:

28.8.1 Location: If cars have center opening doors, controls shall be located on the same wall or walls. If cars have side opening doors, controls shall be located at the side wall or at the front wall next to the door. See Fig. 28d.

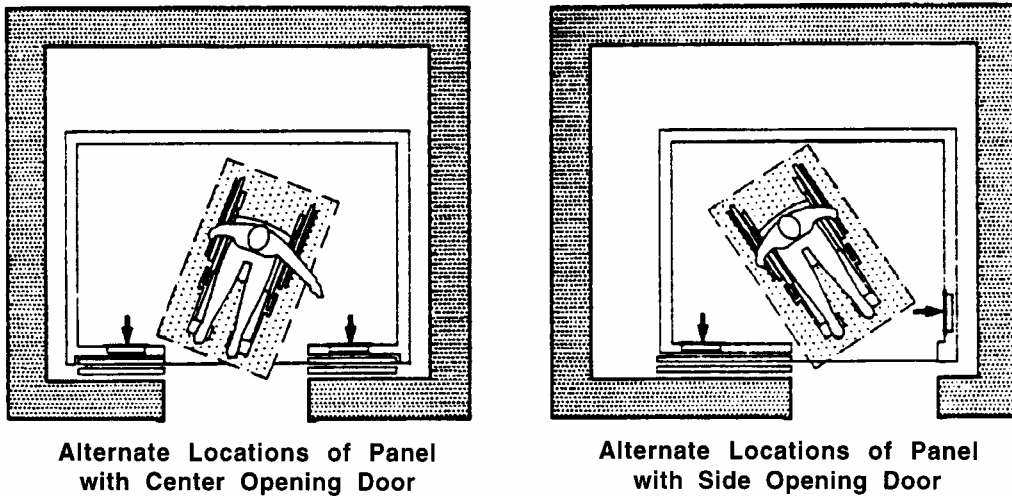

Elevator Car Control Locations
Figure 28d

28.8.2 Height: All floor buttons shall be no higher than 54 inches (54" = 1372mm) above the finish floor for side approach and 48 inches (48" = 1219mm) for front approach. Emergency controls, including the emergency alarm and emergency stop, shall be grouped at the bottom of the panel and shall have their centerlines no less than 35 inches (35" = 889mm) above the finish floor. See Fig. 28e and 28f.

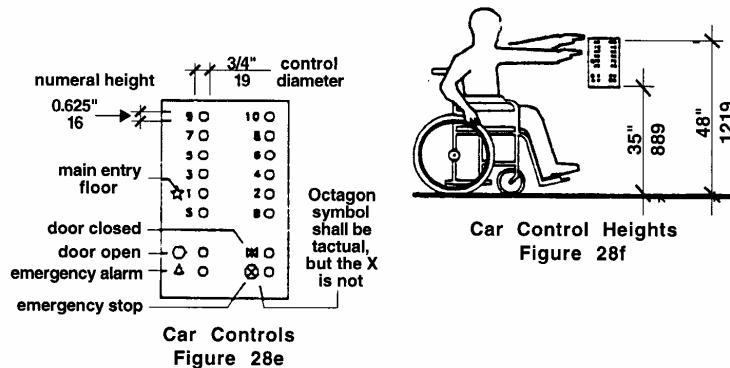

28.00: **ELEVATORS**

- 28.8.3 Buttons: All control buttons shall be at least $\frac{3}{4}$ of an inch ($\frac{3}{4}$ " = 19mm) in their smallest dimension. They shall be raised or flush.
- 28.8.4 Tactile, *Braille*, and Visual Control Indicators: All control buttons shall be designated by *Braille* and by raised standard alphabet characters for letters, arabic characters for numerals, or standard symbols as shown in **Fig. 28e**.
- Raised and *Braille* characters and symbols shall comply with **521 CMR 41.00: SIGNAGE**.
 - The call button for the main entry floor shall be designated by a raised star at the left side of the floor designation. *See Fig. 28e*.
 - All raised designations for control buttons shall be placed immediately to the system shall be placed immediately to the left of the button to which they apply.
 - Applied plates, permanently attached, are an acceptable means to provide raised control designations.
 - Floor buttons shall be provided with visual indicators to show when each call is registered. The visual indicators shall be extinguished when each call is answered.

28.9 **CAR POSITION INDICATORS**

In elevator cars, a visual car position indicator shall be provided in compliance with the following:

- 28.9.1 Location: The car position indicator shall be located above the car control panel or over the door to show the position of the elevator in the hoistway.
- 28.9.2 Visual and Audible: As the car passes or stops at a floor served by the elevators, the corresponding numerals shall illuminate and an audible signal shall sound.
- Numerals shall be a minimum of $\frac{1}{2}$ inch ($\frac{1}{2}$ " = 13mm) high and shall be illuminated on a contrasting background.
 - The audible signal shall be no less than 20 decibels with a frequency no higher than 1500 Hz.
 - An automatic verbal announcement of the floor number at which a car stops or which a car passes may be substituted for the audible signal.

28.10 **EMERGENCY COMMUNICATIONS**

Where a service location is maintained in a *building*, a two-way emergency communication system shall be provided between the elevator car and the service location.

- 28.10.1 The highest operable part of a two-way communication system shall be a maximum of 48 inches (48" = 1219mm) from the floor of the car.
- 28.10.2 It shall be identified by a raised symbol and lettering complying with **521 CMR 41.00, SIGNAGE**, and located adjacent to the device.

28.00: **ELEVATORS**

28.10.3 The emergency intercommunication system shall not require voice communication. Lights that indicate that emergency contact has been made and is being responded to would meet this requirement.

28.10.4 If the system uses a handset, the length of the cord from the panel to the handset shall be at least 29 inches (29" = 737mm). Said handsets shall be equipped with hearing amplification.

28.10.5 If the system is located in a closed compartment the compartment door hardware shall conform to **521 CMR 39.00, CONTROLS**.

28.11 **ILLUMINATION LEVELS**

The *level* of illumination at the car controls, platform, car threshold and landing sill shall be at least five footcandles (53.8 lux).

28.12 **WHEELCHAIR LIFTS/ LIMITED USE ELEVATORS:**

Platform lift devices, shall comply with the following:

28.12.1 General: Vertical wheelchair lift devices and Limited use elevators may be used as a part of an *accessible route* of travel in lieu of an elevator under any of the following circumstances.

- a. To provide an *accessible route* to a performing area (stage) in an assembly occupancy.
- b. To comply with the wheelchair viewing position line-of-sight and dispersion requirements of **521 CMR 14.4.1**.
- c. In existing buildings where no other work is being performed, except for the installation of a vertical wheelchair lift.
- d. In existing *buildings* of less than three *stories* in height or that have less than 3000 square feet per *story* unless the *building* is a shopping center, a shopping mall, or the professional office of a health care provider.
- e. To provide vertical access where the distance between floors is less than a full *story* and where a *ramp* is not feasible.

28.12.2 Vertical wheelchair lifts shall comply with the following:

- a. **521 CMR 24.4, Landings, 521 CMR 29.00: FLOOR SURFACES,** and **521 CMR 39:00 CONTROLS;**
- b. Platform size shall be a minimum of 36 inches wide by 54 inches deep (36" by 54" = 914mm by 1372mm)
- c. The wheelchair lift shall be recessed into the floor, at all levels, so that it is flush with the finished floor or grade. Where recessing the lift is not possible and a *ramp* must be used, the *ramp* shall comply with **521 CMR 24.00: RAMPS**.
- d. If the wheelchair lift is key operated, a buzzer and intercom system must be installed at the lift and connected to a location within the building where the key is maintained.

28.00: ELEVATORS

- e. Doors or gates shall comply with the requirements of **521 CMR 26.5** through **521 CMR 26.11.4**. Exception: Where a door or gate is provided in the wider side of any lift platform that is less than 54 inches (54" = 1372mm) in any dimension, the door or gate shall be a minimum of 42 inches (42" = 1067mm) wide and shall comply with the applicable requirements of **521 CMR 26.6** through **521 CMR 26.11.4**.
- f. Wheelchair lifts must be permanently installed and maintained in operating condition at all times.

28.12.3 Limited use elevators shall comply with the following:

- a. The cab size shall be a minimum of 36 inches wide by 60 inches deep (36" by 60" = 914mm by 1524mm) with the door opening on the 36 inch (36" = 914mm) side.
- b. The interior elevator door or gate shall be automatic.
- c. The exterior doors shall comply with **521 CMR 26.00: DOORS AND DOORWAYS**.
- d. The elevator meet all other requirements of **521 CMR 28.2 through 28.6** and **521 CMR 28.8 through 28.11**.

28.12.4 Inclined wheelchair lifts may be used as a part of an *accessible route* of travel in lieu of an elevator only under the following circumstances.

- a. To provide an *accessible route* to a performing area (stage) in an assembly occupancy.
- b. In an existing *building* where no other work is being performed and no other alternative is available such as a vertical wheelchair lift, limited use elevator or a *ramp*.

28.12.5 Inclined wheelchair lifts shall comply with the following:

- a. The platform shall be a minimum of 30 inches wide by 48 inches long (30" by 48" = 762mm by 1219mm).
- b. A permanent folding seat shall be provided on the lift.
- c. If the wheelchair lift is key operated, a buzzer and intercom system must be installed at the lift and connected to a location within the *building* where the key is maintained.
- d. All controls and operating mechanisms shall comply with **521 CMR 39.00: CONTROLS**.
- e. Inclined wheelchair lifts must be permanently installed and maintained in operating condition at all times.
- f. Clear floor space must be provided at all entry and exit locations to the inclined wheelchair lift in accordance with the clear floor space requirement as cited in 521 CMR 26.6.3 and 26.6.4.