

521 CMR 30.00: PUBLIC TOILET ROOMS

30.1 GENERAL

Each public toilet room provided on a *site* or in a *building* shall comply with 521 CMR.

- a. In each adult public toilet room, at least one water closet and one sink in each location shall be *accessible* to persons in wheelchairs, or a separate *accessible* unisex toilet room shall be provided at each location. Adult water closets shall comply with the provisions of **521 CMR 30.1 through 30.13**.
- b. Where children's toilet rooms are provided, at least one water closet and one sink in each location shall be *accessible* to children in wheelchairs, or a separate *accessible* unisex toilet room shall be provided at each location. Children's toilet rooms shall comply with the provisions of **521 CMR 30.14 through 30.20**. For purposes of 521 CMR, pre-kindergarten school is defined as a school which serves children from infancy up until but not including kindergarten. Elementary school is defined as a school which serves grades kindergarten through six.

30.1.1 The installation of unisex toilet room in *lieu* of fully *accessible* men's and women's room is permitted by 521 CMR. See also **521 CMR 30.2, Location**.

30.1.2 Portable Toilets: For single user portable toilets clustered at a single location, at least 5% but not less than one accessible toilet unit shall be installed at each cluster. *Accessible* units shall be identified by the International Symbol of Accessibility. Portable units at construction sites used exclusively by *construction* personnel are not required to be *accessible*.

30.2 LOCATION

Accessible toilet rooms shall be on an *accessible route*. Where unisex toilet room(s) are provided, they shall be located in the same area as other toilet rooms.

30.3 VESTIBULES

Where vestibules are provided, they shall comply with **521 CMR 25.3, Vestibules**.

30.4 DOORS TO SINGLE USER TOILET ROOMS

Doors to single user toilet rooms may swing into the room if the door has a self-closing device and maneuvering space is provided in accordance with **521 CMR 26.6**. The door may swing into the room if there is a clear floor space of 30 inches by 48 inches (30" = 762mm by 48" = 1219mm) beyond the swing of the door.

30.5 CLEAR FLOOR SPACE

An unobstructed turning *space* complying with **521 CMR 6.3, Wheelchair Turning Space** shall be provided within an *accessible* toilet room. The *clear floor space* at fixtures and controls, the *accessible route*, and the turning *space* may overlap.

30.6 TOILET STALLS

If toilet stalls are provided, then at least one shall be a standard *accessible* toilet stall. Where six or more stalls are provided in a toilet room, at least one alternate *accessible* toilet stall (See **Fig. 30c**) shall be provided in addition to the standard *accessible* toilet stall. *Accessible* toilet stalls shall be on an *accessible route*.

30.6.1 Standard *Accessible* Toilet Stall: Standard *accessible* toilet stalls shall be at least 60 inches (60" = 1524mm) wide and 72 inches (72" = 1829mm) deep. See **Fig. 30a and 30b**. Arrangements shown for standard *accessible* toilet stalls may be reversed to allow either a left- or right-hand approach. Water closets in *accessible* stalls shall be located on the 60 inch (60" = 1524mm) wall and shall comply with **521 CMR 30.7, Water closets**.

- a. *Accessible* toilet stalls shall have a door that swings out or slides and has a 32 inch (32" = 813mm) clear opening.
- b. The stall door shall have an automatic self-closing hinge device, a pull device on both sides of the door to assist in closing and opening the door, and a lock located approximately 36 inches (36" = 914mm) above the floor that does not require tight grasping, pinching, or twisting of the wrist to operate.

30.00: continued

- c. There shall be 18 inches (18" = 457mm) of clear space on the latch pull side of the door.
- d. A coat hook shall be provided at a maximum height of 54 inches (54" = 1372mm) above the floor.

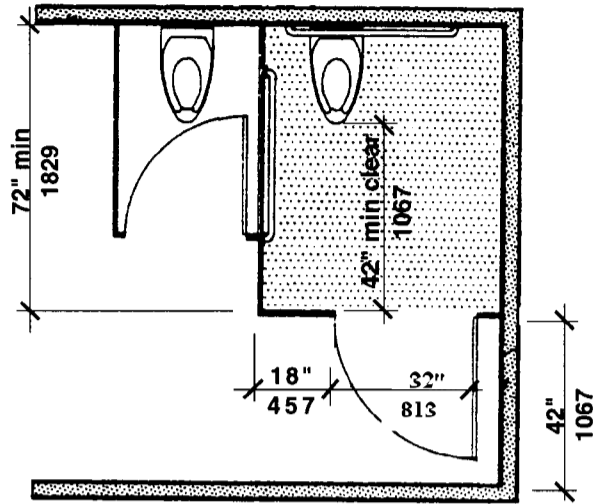

Accessible Toilet Stall (Left Approach)
Figure 30a

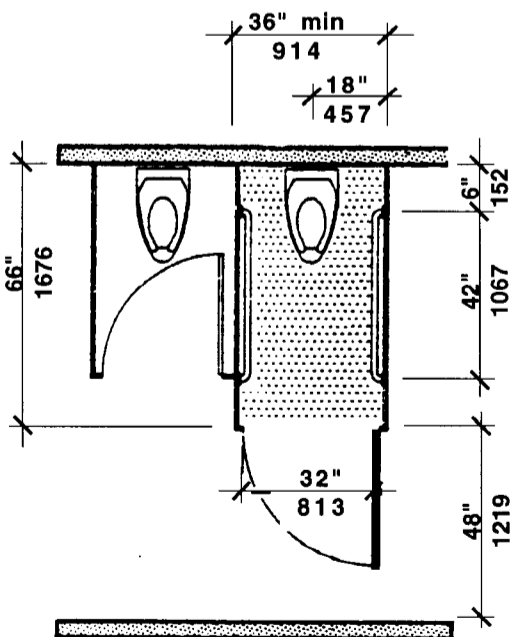
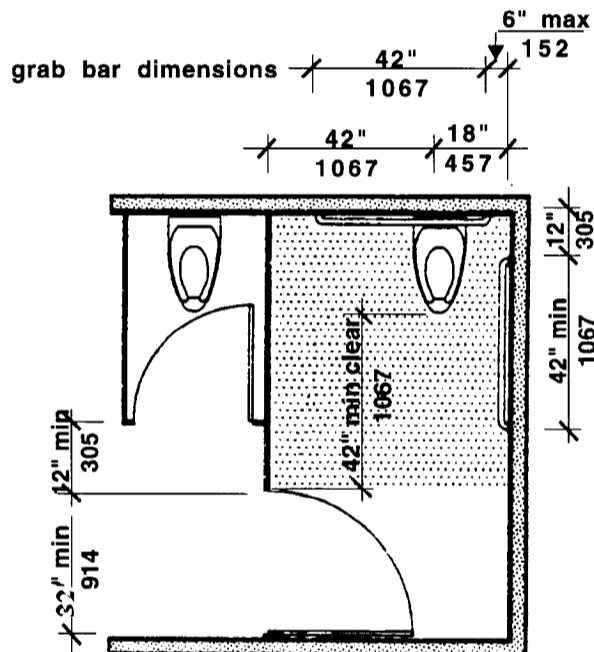

Alternate Accessible Stall
(in addition to accessible stall)
Figure 30c

30.00: continued

30.6.2 *Alternate Accessible Stall*: Alternate *accessible* toilet stalls shall be 36 inches (36" = 914mm) wide with an outward swinging, self-closing door and parallel grab bars. See **Fig. 30c**.

- a. The alternate toilet stall shall have a door that swings out or slides and has a 32 inch (32" = 813mm) clear opening.
- b. The stall door shall have an automatic self-closing hinge device, a pull device on both sides of the door to assist in closing and opening the door, and a lock located approximately 36 inches (36" = 914mm) above the floor that does not require tight grasping, pinching, or twisting of the wrist to operate.
- c. A coat hook shall be provided at a maximum height of 54 inches (54" = 1372mm) above the floor.

30.7 WATER CLOSETS

That are required to be *accessible* shall comply with the following:

30.7.1 *Clear floor space*: *Clear floor space* for water closets not in stalls shall comply with **Fig. 30d**. *Clear floor space* may be arranged to allow either a left-handed or right-handed approach to the water closet.

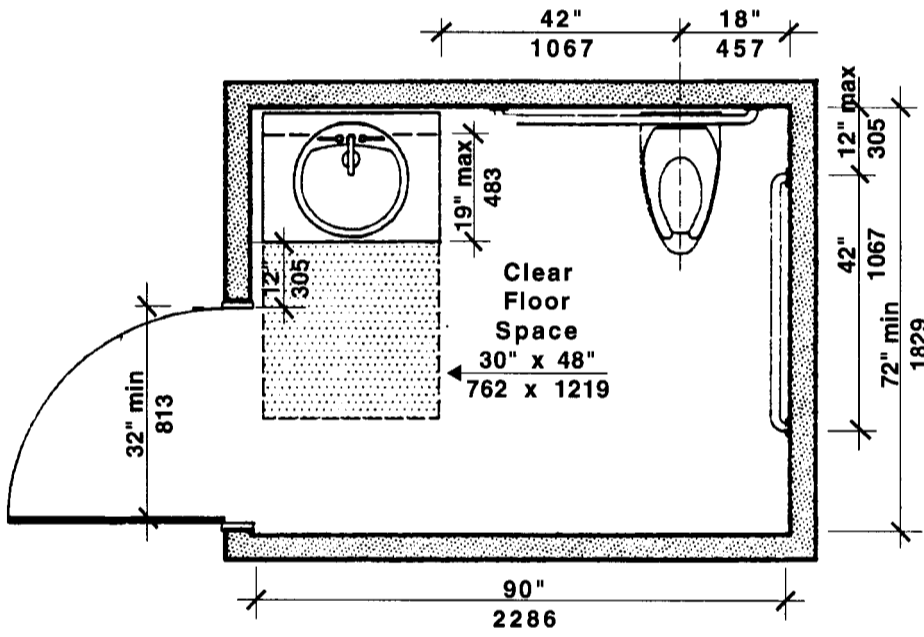

**Accessible Unisex Toilet Room
Figure 30d**

30.00: continued

30.7.2 Location: The centerline of the water closet shall be located 18 inches (18" = 457mm) from the nearest side wall and at least 42 inches (42" = 1067mm) from the farthest side wall or the closest edge of an adjacent fixture. There shall be at least 42 inches (42" = 1067mm) clearance between the front edge of the water closet and the nearest wall or fixture.

30.7.3 Height: Water closets shall be 17 inches to 19 inches (17" to 19" = 432mm to 483mm) high, measured to the top of the water closet seat. See Fig. 30e.

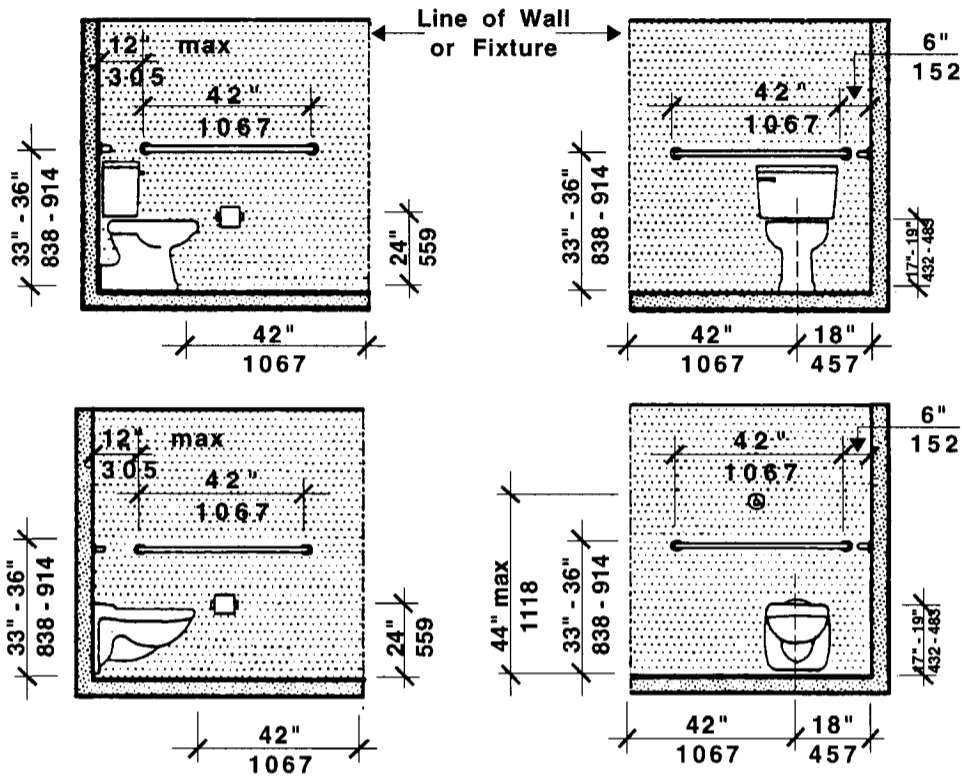

Accessible Toilet Stall Elevations
Figure 30e

30.7.4 Seats: Water closet seats shall not be spring mounted to return to a lifted position.

30.7.5 Flush Controls: Flush controls shall be hand operated or automatic and shall comply with **521 CMR 39.5, Operation**. Controls for flush valves shall be mounted on the wide side of water closet no more than 44 inches (44" = 1120mm) above the floor.

30.7.6 Toilet Paper Dispensers: Toilet paper dispensers shall be located on the side wall closest to the water closet. The centerline of the roll shall be set at a minimum height of 24 inches (24" = 610mm) above the floor. Dispensers that control delivery or that do not permit continuous paper flow are not allowed.

30.8 GRAB BARS

For the standard accessible toilet stall the water closet shall have two grab bars 42 inches (42" = 1067mm) long, one on the wall in back of the water closet and one on the side wall closest to the water closet.

For the alternate accessible toilet stall the water closet shall have two parallel grab bars, 42 inches long (42" = 1067mm) installed on the side walls and located a minimum of six inches (6" = 76mm) from the interior corner.

30.8.1 Location: The side grab bar shall be located a maximum of 12 inches (12" = 305mm) from the interior corner. The rear grab bar shall be located a maximum of six inches (6" = 152mm) from the interior corner.

30.00: continued

30.8.2 Height: Grab bars shall be set at a height of 33 to 36 inches (33" to 36" = 838mm to 914mm) above and parallel to the floor. Where a tank prevents location of the rear grab bar, a bar may be installed three inches (3" = 76mm) above the tank. Where a flushometer prevents the location of a 42 inch (42" = 1067mm) rear grab bar, one grab bar, 36 inches (36" = 914mm) shall be installed to the side of the flushometer, located three inches (3" = 76mm) from the closest edge of the flushometer.

30.8.3 Thickness: Grab bars shall be between 1¼ inches and 1½ inches (1¼" to 1½" = 32mm to 38mm) in outside diameter, have a ½ inch (½" = 38mm) clearance between the bar and the wall. See Fig. 30f.

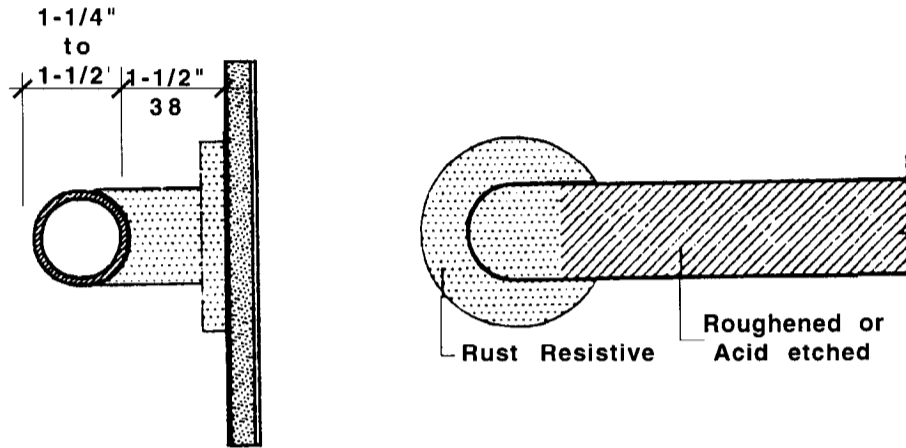

Grab Bars
Figure 30f

30.8.4 Material: Grab bars shall also be non-rusting and acid-etched or roughened. Grab bars shall comply with the *structural strength* defined in **521 CMR 5.00, DEFINITIONS**.

30.8.5 Dispensers or other devices shall not be mounted above the grab bars.

30.9 SINK

Sinks, including vanities, shall comply with the following:

30.9.1 *Clear floor space:* A clear floor space complying with **521 CMR 6.3, Wheelchair Turning Space** shall be provided in front of a sink to allow forward approach. The clear floor space shall be on an accessible route and shall extend no more than a maximum of 19 inches (19" = 483mm) underneath the sink. See Fig. 30g.

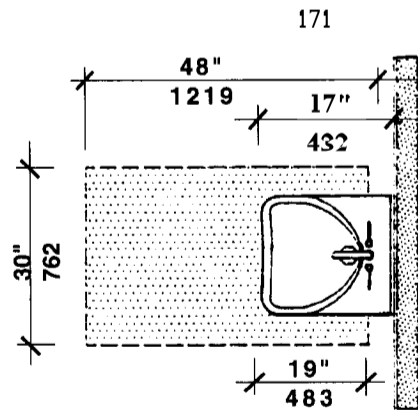

Clear Floor Space
Figure 30g

30.9.2 Height: Sinks shall be mounted with the rim no higher than 34 inches (34" = 864mm) above the finish floor. See Fig. 30h. Sinks shall also extend a minimum of 17 inches (17" = 432mm) from the wall to the front of the sink or counter.

30.00: continued

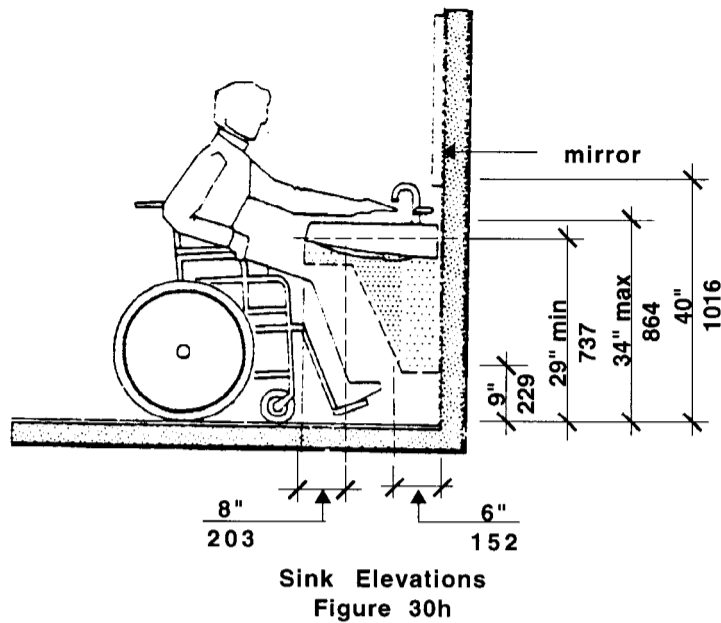

30.9.3 **Knee Clearance:** Knee clearance shall be provided underneath the sink which is 27 inches (27" = 685mm) minimum from the floor to the underside of the sink and extends eight inches (8" = 205mm) minimum measured from the front edge underneath the sink back towards the wall; if a minimum of nine inches (9" = 230mm) of toe clearance is provided, a maximum of six inches (6" = 150mm) of the 48 inches (48" = 1220mm) of clear floor space required at the fixture may extend into the toe space. *See Fig. 30h.*

30.9.4 **Depth:** Sink depth shall not exceed six inches 6½ inches (6½" = 165mm).

30.9.5 **Piping:** Sink traps and drains shall be located as close to rear walls as possible. Hot water and drain pipes exposed under sinks shall be recessed, insulated, or guarded. There shall be no sharp or abrasive surfaces under sinks.

30.9.6 **Faucets:** Faucets shall be operable with one hand and shall not require tight grasping, pinching, or twisting of the wrist. Lever-operated, push-type, touch-type, or electronically controlled mechanisms are acceptable designs. If self-closing valves are used the faucet shall remain open for at least ten seconds.

30.10 URINALS

Where one or more urinals is provided, at least one urinal shall be *accessible*. *See Fig. 30i.*

30.10.1 **Height:** *Accessible* urinals shall be stall-type or wall-hung with an elongated rim at a maximum of 17 inches (17" = 432mm) above the finish floor.

30.10.2 **Clear floor space:** A *clear floor space* shall be provided in front of an *accessible* urinal to allow forward approach. This *clear space* shall adjoin or overlap an *accessible route* and shall comply with **521 CMR 6.3, Wheelchair Turning Space**. Urinal shields that do not extend beyond the front edge of the urinal rim may be provided with 29 inches (29" = 737mm) clearance between them.

30.10.3 **Flush Controls:** Flush controls shall be hand operated or automatic, and shall comply with **521 CMR 39.5, Operation** and shall be mounted no more than 44 inches (44" = 1118mm) above the finish floor. *See Fig. 30i.*

30.00: continued

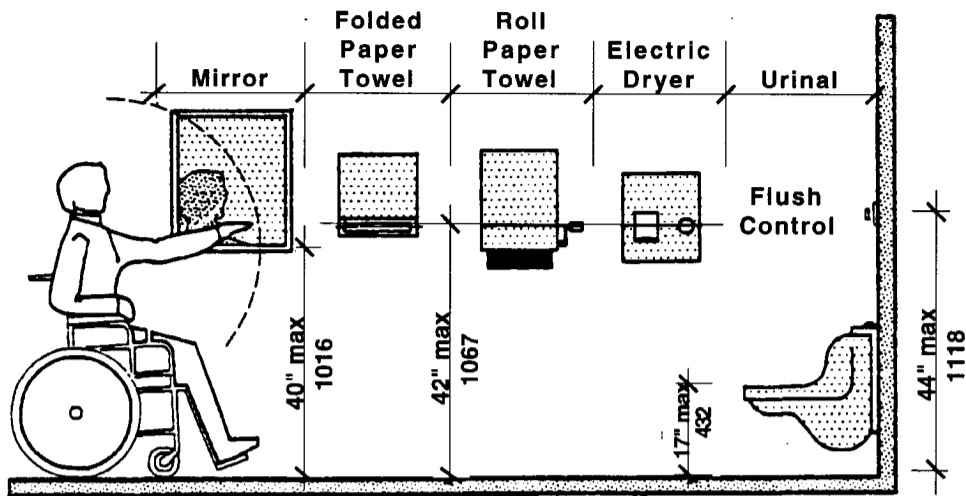

Dispenser Elevations
Figure 30i

30.11 MIRROR

The top of any shelf and or bottom of any mirror that is provided above a sink shall be set with the bottom edge of the reflecting surface no higher than 40 inches (40" = 1016mm) above the finish floor. See Fig. 30i.

30.12 DISPENSERS

Towel dispensers, drying devices, or other types of devices and dispensers shall have at least one of each device mounted within the *zone of reach*. At least one of each device shall be located within reach of a person using the *accessible* sink and shall comply with **521 CMR 39.5, Operation**. See Fig. 30i.

30.13 CONTROLS AND RECEPTACLES

If controls, receptacles, or other equipment is provided, then at least one of each shall be on an *accessible route* and shall comply with **521 CMR 39.00: CONTROLS**.

30.14 CHILDREN'S WATER CLOSETS

Where provided, shall comply with the following:

30.14.1 *Clear floor space*: *Clear floor space* for water closets shall comply with **521 CMR 30.5, Clear Floor Space**. *Clear floor space* may be arranged to allow either a left-handed or right-handed approach.

30.14.2 *Location*: The centerline of the water closet shall be located 11 inches (11" = 279mm) from the nearest side wall for pre-kindergarten; 11 to 15 (11" to 15" = 279mm to 381mm) for kindergarten to third grade and 15 to 18 inches (15" to 18" = 381mm to 457mm) for fourth grade to sixth grade. The water closet shall also be located 42 inches (42" = 1067mm) from the centerline of the water closet to the opposite wall or closest edge of next fixture.

30.14.3 *Height*: Water closets shall be set at a height measured from the floor to the top of the seat as follows:

Pre-kindergarten:	11½" to 12½" (292mm to 318mm)
Kindergarten to third grade:	12" to 15" (305mm to 381mm)
Fourth grade to sixth grade:	15" to 17" (381mm to 432mm)

30.14.4 *Flush Controls*: Controls for flush valves on water closets used by children shall be mounted on the wide side of water closet within 20 to 30 inches (20" to 30" = 508mm to 762mm) above the floor.

30.00: continued

30.14.5 Toilet paper dispensers: Toilet paper dispensers used by children shall be centered above finished floor, as follows:

Pre-kindergarten:	14" (356mm)
Kindergarten to third grade:	14" to 17" (356mm to 432mm)
Fourth grade to sixth grade:	17" to 19" (432mm to 483mm)

30.15 CHILDREN'S GRAB BARS

The water closet shall have two grab bars, 42 inches (42" = 1067mm) long, one mounted on the wall in back of the water closet and one on the side wall closest to the water closet and located no more than six inches (6" = 152mm) from the interior corner. Where a tank prevents location of the rear grab bar, a bar may be installed three inches (3" = 76mm) above the tank. Where a flushometer prevents the location of a 42 inch (42" = 1067mm) rear grab bar, one grab bar, 36 inches (36" = 914mm) shall be installed to the side of the flushometer, located three inches (3" = 76mm) from the closest edge of the flushometer.

30.15.1 Height: Grab bars shall be mounted from the floor to the top of the grab bar as follows:

Pre-kindergarten:	18" to 20" (457mm to 508mm)
Kindergarten to third grade:	20" to 25" (508mm to 635mm)
Fourth grade to sixth grade:	25" to 27" (635mm to 686mm)

30.15.2 Thickness: The outside diameter of grab bars shall be as follows:

Pre-kindergarten:	1" (25mm)
Kindergarten to sixth grade:	1¼" to 1½" (32mm to 38mm)

30.16 CHILDREN'S SINK

Sinks including vanities shall comply with the following:

30.16.1 *Clear floor space:* A *clear floor space* complying with **521 CMR 30.5, Clear Floor Space** shall be provided in front of a sink to allow a forward approach. The *clear floor space* shall be on an *accessible route* and shall extend no more than a maximum of 19 inches (19" = 483mm) underneath the sink.

30.16.2 Height: Sinks shall be mounted with the rim no higher than 30 inches (30" = 762mm) above the finish floor. A clearance of at least 25 inches (25" = 635mm) above the finish floor to the bottom of the apron shall be provided. Knee and toe clearance shall be at least 30 inches (30" = 762mm) wide and 19 (19" = 483mm) deep.

30.16.3 Piping: Sink traps and drains shall be located as close to rear walls as possible. Hot water and drain pipes exposed under sinks shall be recessed, insulated, or guarded. There shall be no sharp or abrasive surfaces under sinks.

30.16.4 Faucets: Faucets shall be operable with one hand and shall not require tight grasping, pinching, or twisting of the wrist. Lever-operated push-type, touch-type, or electronically controlled mechanisms are acceptable designs. If self-closing valves are used, the faucet shall remain open for at least ten seconds.

30.17 CHILDREN'S URINALS

Where one or more urinal is provided, at least one urinal shall be *accessible*.

30.17.1 Height: The *accessible* urinal shall be stall-type or wall-hung with an elongated rim at a maximum of 15 inches (15" = 381mm) above the finish floor.

30.17.2 Flush Controls: Flush controls shall be hand operated or automatic, and shall be mounted no more than 44 inches (44" = 1120mm) above the finish floor.

30.00: continued

30.18 CHILDREN'S MIRROR

The top of any shelf and or bottom of any mirror which is provided above a sink shall be set with the bottom edge of the reflecting surface no higher than 31 inches (31" = 787mm) above the finish floor.

30.19 CHILDREN'S DISPENSERS

Towel dispensers, drying devices, or other types of devices and dispensers shall have at least one of each device mounted within the *zone of reach*, and at least one of each device shall be located within reach of a person using the *accessible* sink.

30.20 CHILDREN'S CONTROLS AND RECEPTACLES

If controls , receptacles, or other equipment are provided, then at least one of each shall be mounted no higher than 36 inches (36" = 914mm) above the floor to the centerline of the operable portion of the control.

NON-TEXT PAGE