

521 CMR 42.00: **GROUP 1 BATHROOMS**

42.1 **GENERAL**

In *Group 1 dwelling units*, (see **521 CMR 9.2, Applicability**) *bathrooms* and *half bathrooms* shall comply with the following:

42.1.1 Number: If more than one *bathroom* is provided, whether a full bath or *half bath*, and one *bathroom* is a *captive bathroom* (a *bathroom* only entered through a bedroom) then both must comply unless the *captive bathroom* has two entries, one from the *bedroom* and one from the corridor, then only the *captive bathroom* is required to comply. If two common *bathrooms* are provided, then only one full *bathroom* must comply. If two *captive bathrooms* are provided, then both must comply.

42.2 **CLEAR FLOOR SPACE:**

Shall be as defined in **521 CMR 6.4, Clear Floor or Ground Space for Wheelchairs**. *Clear floor space* shall be available at each fixture as shown below to enable users to reach fixture controls and to transfer out of a wheelchair. When a *bathroom* is adapted, the *clear floor space* must be able to be made free of obstructions, other than those shown in the diagram. The *clear floor space* for one fixture may overlap the *clear floor space* for other fixtures. The *clear floor space* for the tub or the water closet is measured from the closest edge of that fixture. The *clear floor space* for the sink may extend a maximum of 19 inches (19" = 483mm) under the sink. Wing walls may not intrude on the minimum *clear floor space*.

42.3 **MANEUVERING SPACE:**

Shall be available so that, at a minimum, a person using a wheelchair can enter, close the door, use each of the fixtures, reopen the door, and exit. See **Fig. 42a** and **42b**.

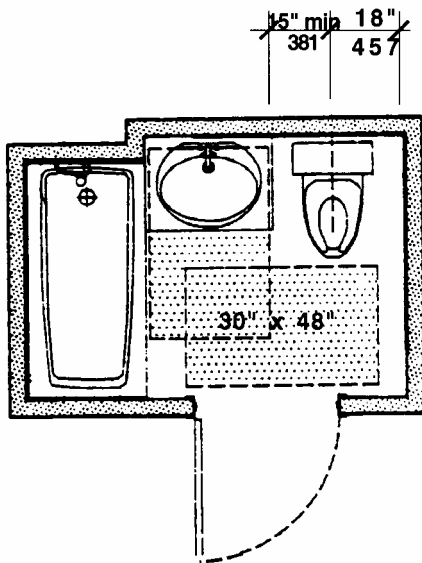

**Maneuvering Space
Figure 42a**

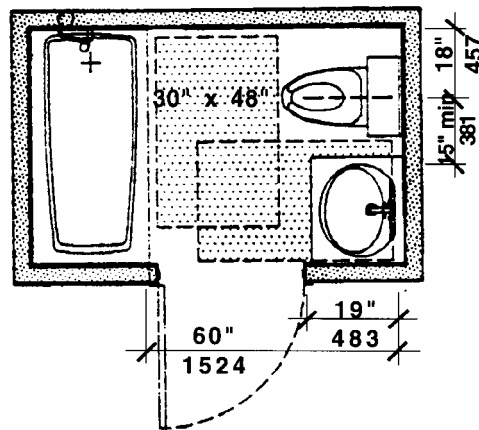

**Maneuvering Space
Figure 42b**

42.00: **GROUP 1 BATHROOMS**

42.4 **DOORS**

Shall be capable of complying with **521 CMR 26.5, Width** through **521 CMR 26.11, Door Hardware**.

42.4.1 **Operation:** Doors may swing into the *bathroom* if the swing of the door does not impede *clear floor space*. If the door impedes the *clear floor space*, the doors shall be capable of being adapted to swing out, fold or slide.

42.5 **WATER CLOSETS**

Shall comply with the following:

42.5.1 **Clear Floor Space:** As defined in **521 CMR 42.2, Clear Floor Space**, shall be provided or shall be capable of being provided without *structural change* in at least one of two specific locations at the water closet. One shall be beside the water closet with its short edge parallel to the wall behind the water closet. The other shall be in front of the water closet with its long edge parallel to the wall behind the water closet.

42.5.2 **Location:**

- a. When a water closet is located between a wall and a fixture, its centerline shall be 18 inches (18" = 457mm) from the wall. If the *clear floor space* is provided in front of the water closet, the centerline of the water closet shall be a minimum of 15 inches (15" = 381mm) from the closest edge of the fixture. See **Fig. 42c**.

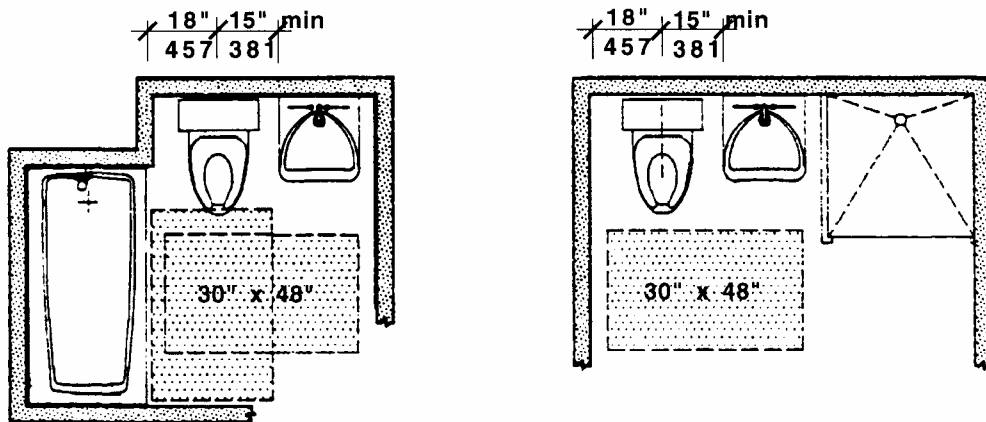

Toilet between Fixtures

Toilet between Wall and Fixture

Toilet Locations
Figure 42c

- b. When a water closet is located between two fixtures, its centerline shall be 18 inches (18" = 457mm) from a bathing fixture and a minimum of 15 inches (15" = 381mm) from other types of fixtures. See **Fig. 42c**.

521 CMR: ARCHITECTURAL ACCESS BOARD

42.00: **GROUP 1 BATHROOMS**

42.5.3 Wall reinforcement: Walls adjacent to and behind the water closet shall be capable of structurally supporting the future installation of grab bars from 32 to 38 inches (32" to 38" = 813mm to 965mm) above the floor. The back wall shall have reinforcement from the interior corner to a distance of six inches (6" = 152mm) beyond the widest part of the water closet. The side wall shall have reinforcement from the interior corner to a distance of six inches (6" = 152mm) beyond the front edge of the water closet, unless interrupted by a door or other fixture, then the reinforcement shall be installed as far as possible.

When the water closet is located between two fixtures, the wall reinforcement behind the water closet shall be extend at least six inches (6" = 152mm) beyond the widest part of the water closet.

42.6 **SINKS**

At least one sink in a *bathroom* must meet the following:

42.6.1 Vanity Cabinets: If a cabinet is provided under a sink, it shall be capable of being removed without structural change.

42.6.2 Knee *Space* Width: The sink shall have or be capable of having a knee *space* of 30 inches (30" = 762mm) in width.

42.6.3 Knee *Space* Depth: The front edge of the sink fixture, or the countertop in which a sink is located, shall be a minimum of 19 inches (19" = 482mm) from the back wall or shall be capable of being relocated to create a *space* of that depth under the sink.

42.6.4 Height: The sink shall be capable of being relocated without structural change.

42.6.5 *Clear Floor Space*: Shall be provided at the sink, as defined in **521 CMR 42.2, Clear Floor Space** and shall be perpendicular to the face of the sink and may extend under the sink. *See Fig. 42d.*

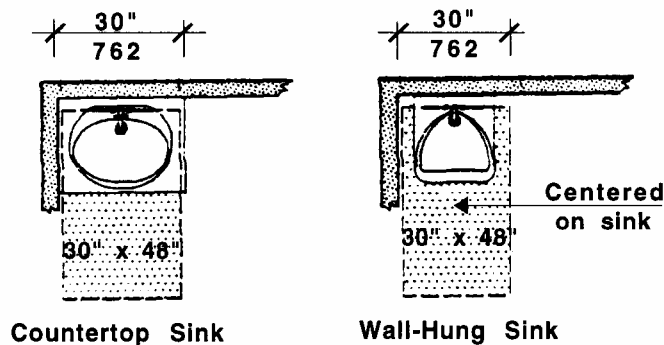

Sinks
Figure 42d

42.00: **GROUP 1 BATHROOMS**

42.7 **BATHING FIXTURES**

If more than one bathing fixture is provided in a *bathroom*, at least one must meet the requirements of 521 CMR 42.

42.7.1 Bathtubs shall comply with the following:

- a. **Size:** Bathtubs shall be at least a nominal 60 inches (60" = 1524mm) long.
- b. **Clear Floor Space:** At the bathtub, as defined in **521 CMR 42.2, Clear Floor Space** shall be parallel to the face of the tub.
- c. **Wall Reinforcement:** All tub walls shall be capable of structurally supporting the future installation of grab bars from six inches (6" = 152mm) above the tub rim to a height of 48 inches (48" = 1219mm) above the tub bottom and shall extend the length and width of the tub.
- d. **Door Enclosure:** Tracks for sliding doors or enclosures mounted on the rim of a bathtub must be capable of removal to provide a smooth tub rim for transfer.

42.7.2 Showers shall comply with the following:

- a. **Size:** Shower stalls shall be a minimum, nominal dimension of 36 inches by 36 inches (36" x 36" = 914mm x 914mm).
- b. **Minimum Clear Floor Space:** At the shower, as defined in **521 CMR 42.2, Clear Floor Space** shall be located parallel to and centered on the shower stall opening.
- c. **Wall Reinforcement:** All shower walls shall be capable of structurally supporting the future installation of grab bars, seats, etc., from a height of six inches (6" = 152mm) to 48 inches (48" = 1219mm) above the floor and shall extend the full width and length of the shower stall. Grab bars shall not be located behind the seat.
- d. **Door:** The opening of the shower stall must be 32 inches (32" = 813mm) wide. If a shower door is provided, it shall be capable of swinging open 180 degrees or capable of being removed.
- e. **Seat:** If a wall mounted seat is provided, it shall be located on a wall adjacent to the opening. The seat shall be mounted with the edge as close as possible to the door opening to allow a safe transfer.
- f. **Hardware Location:** Mixing valves shall be mounted on the wall opposite the seat. The centerline of the shower controls shall be located between 38 inches and 48 inches (38" to 48" = 965mm to 1219mm).
- g. Where curbs are provided, they shall not exceed four inches (4" = 102mm) in height.

42.7.3 Soap Tray shall not have a hand hold feature unless it can support 250 lbs for five minutes. Soap dispensers, holders, etc., shall be located within the *zone of reach* from the seat.

42.7.4 Prefabricated Units: In prefabricated showers and tubs, structural reinforcement for grab bars must be in full contact with the surface of walls of the unit on which grab bars may be mounted as described in **521 CMR 42.7.1 (c)** and **521 CMR 42.7.2 (c)**.

521 CMR: ARCHITECTURAL ACCESS BOARD

42.00: **GROUP 1 BATHROOMS**

42.8 **OUTLETS AND CONTROLS**

Shall comply with **521 CMR 39.00: CONTROLS.**

42.9 **ALARMS**

Shall comply with **521 CMR 40.00: ALARMS.**