

ADDENDA
TO THE
1997
MASSHIGHWAY
HIGHWAY DESIGN MANUAL

INTERIM GUIDANCE

FOR
CONFORMANCE
WITH THE

AASHTO

A POLICY ON GEOMETRIC DESIGN
OF
HIGHWAYS AND STREETS
2001

APRIL 2003

INTERIM GUIDANCE TO THE 1997 HIGHWAY DESIGN MANUAL

The following information is addenda to the 1997 MassHighway Highway Design Manual. These changes were made to address updated design guidance from the AASHTO *A Policy on Geometric Design of Highways and Street 2001* (Green Book). Significant changes were made from the previous version of the AASHTO Green Book that affect the design of roadways in Massachusetts. These changes were made by AASHTO design committees to address the need for improved safety and mobility while recognizing the need for agencies and designers to be more sensitive in their approach to design.

On March 14, 2002, the Federal Highway Administration (FHWA) officially adopted the 2001 AASHTO Green Book as minimum design standards for projects on the National Highway System. At that time, the FHWA gave the states one year to address compliance of the Green Book with their own standards. This document serves that purpose. Changes were made primarily to address items affecting the 13 AASHTO controlling criteria. In addition, this document includes dimensions in both the English and Metric systems of measurement, with most dimensions rounded to even English values.

Designers should design to desirable standards where practical and minimum standards where feasible. This is the flexibility in design inherent in the AASHTO guidance. The context of the roadway should always be considered and exceptions to the minimum standards may be warranted based on constraints. The normally requires justification and documentation in the form of a design exception report to assure that the designer used sound engineering judgment to address safety and mobility objectives.

MassHighway is currently considering more significant revisions to the *Highway Design Manual* relative to context sensitivity and community concerns. In the interim period between now and when a fully revised manual is issued, this document should be used to design all roadways in Massachusetts. Since most of the values contained in this document are within the range of the desirable and minimum standards in the *1997 Highway Design Manual*, projects currently under design or construction may continue to use the 1997 values at the direction of the project manager.

ADDENDUM TO THE 1997 HIGHWAY DESIGN MANUAL

Page 3.12.0 Section 3.4.1 Design Speed

First sentence is replaced with the following:

Design speed is a selected speed used to determine the various design features of the roadway.

Page 3.13.0 Section 3.4.1 Design Speed

Table 3.6 is replaced with the following Table:

**Table 3.6
DESIGN SPEEDS
(A Design Exception is required when speed selected is outside Table Values)**

Metric Units (meters)		
FUNCTIONAL CLASSIFICATION	U/R	DESIGN SPEED
FREEWAY/EXPRESSWAY	URBAN	DESIGN SPEED SHOULD NOT BE LESS THAN 80 km/h
	RURAL	110 km/h SHOULD BE USED, IN MOUNTAINOUS TERRAIN, A DESIGN SPEED OF 80 km/h TO 100 km/h MAY BE USED
ARTERIAL	URBAN	MAY RANGE FROM 50 km/h TO 100 km/h. BELOW 70 km/h APPROPRIATE FOR BUILT-UP AREAS. ABOVE 80 km/h IS APPROPRIATE FOR OUTLYING AREAS.
	RURAL	LEVEL - 100 to 120 km/h
		ROLLING - 80 to 100 km/h
MOUNTAINOUS - 60 to 80 km/h		
COLLECTOR	URBAN	MINIMUM OF 50 km/h
	RURAL	OVER 2000 ADT: LEVEL - 100 km/h ROLLING - 80 km/h MOUNTAINOUS - 60 km/h SEE PAGE 426 OF 2001 AASHTO POLICY ON GEOMETRIC DESIGN FOR ADT BELOW 2000.
LOCAL	URBAN	MAY RANGE FROM 30 km/h TO 50 km/h DEPENDING ON AREA CONTROLS.
	RURAL	OVER 2000 ADT: LEVEL - 80 km/h ROLLING - 60 km/h MOUNTAINOUS - 50 km/h SEE PAGE 385 OF 2001 AASHTO POLICY ON GEOMETRIC DESIGN FOR ADT BELOW 2000.

Table 3.6 (CONTINUED)

DESIGN SPEEDS

(A Design Exception is required when speed selected is outside Table Values)

English Units (feet)		
FUNCTIONAL CLASSIFICATION	U/R	DESIGN SPEED
FREEWAY/EXPRESSWAY	URBAN	DESIGN SPEED SHOULD NOT BE LESS THAN 50 mph
	RURAL	70 mph SHOULD BE USED, IN MOUNTAINOUS TERRAIN, A DESIGN SPEED OF 50 mph TO 60 mph MAY BE USED
ARTERIAL	URBAN	MAY RANGE FROM 30 mph TO 60 mph. BELOW 45 mph APPROPRIATE FOR BUILT-UP AREAS. ABOVE 50 mph IS APPROPRIATE FOR OUTLYING AREAS.
	RURAL	LEVEL - 60 to 75 mph
		ROLLING - 50 to 60 mph
MOUNTAINOUS - 40 to 50 mph		
COLLECTOR	URBAN	MINIMUM OF 30 mph
	RURAL	OVER 2000 ADT: LEVEL - 60 mph ROLLING - 50 mph MOUNTAINOUS - 40 mph SEE PAGE 426 OF 2001 AASHTO POLICY ON GEOMETRIC DESIGN FOR ADT BELOW 2000.
LOCAL	URBAN	MAY RANGE FROM 20 mph TO 30 mph DEPENDING ON AREA CONTROLS.
	RURAL	OVER 2000 ADT: LEVEL - 50 mph ROLLING - 40 mph MOUNTAINOUS - 30 mph SEE PAGE 385 OF 2001 AASHTO POLICY ON GEOMETRIC DESIGN FOR ADT BELOW 2000.

Page 3.14.0 **Section 3.4.2** **Running Speed**

Third paragraph: replace 30 km/h to 70 km/h with 30 km/h to 75 km/h.

Page 3.15.0 **Section 3.4.3** **Posted Speed**

Delete Figure 3-2

Page 3.17.0 **Section 3.5.1.3** **Composition**

First paragraph: replace 4100 kilograms with 4000 kilograms

Page 3.18.0 **Section 3.5.1.4** **Levels of Service**

Second paragraph: replace Table 3.7 with The Highway Capacity Manual (HCM)

Page 3.18.0 **Section 3.5.1.4** **Levels of Service**

Table 3.8 is replaced with the following Table:

Table 3.8
MINIMUM LEVEL OF SERVICE GUIDELINES

HIGHWAY TYPE	TYPE OF AREA AND APPROPRIATE LEVEL OF SERVICE			
	RURAL LEVEL	RURAL ROLLING	RURAL MOUNTAINOUS	URBAN AND SUBURBAN
FREEWAY ¹	B	B	B	C
ARTERIAL	B	B	C	C
COLLECTOR	C	C	D	D
LOCAL	D	D	D	D

Note: LEVEL OF SERVICE D, E, AND F ARE NOT NORMALLY USED FOR DESIGN.

1. SEE HIGHWAY CAPACITY MANUAL TO DETERMINE LEVEL OF SERVICE FOR FREEWAYS IN DESIGN YEAR.

Reference: "A POLICY ON GEOMETRIC DESIGN OF HIGHWAYS AND STREETS" AASHTO, 2001"

Delete Table 3.7

Third paragraph is replaced with the following:

The approximate braking distance of a vehicle on a level roadway traveling at the design speed of the roadway may be determined from the following equation:

Metric	US Customary
$d = 0.039 \frac{V^2}{a}$	$d = 1.075 \frac{V^2}{a}$ (3-1)
where: d = braking distance, m; V = design speed, km/h; a = deceleration rate, m/s ²	where: d = braking distance, ft; V = design speed, mph; a = deceleration rate, ft/s ²

Studies documented in the literature show that most drivers decelerate at a rate greater than 4.5 m/s² [14.8 ft/s²] when confronted with the need to stop for an unexpected object in the roadway. Approximately 90 percent of all drivers decelerate at rates greater than 3.4 m/s² [11.2 ft/s²]. Such decelerations are within the driver's capability to stay within his or her lane and maintain steering control during the braking maneuver on wet surfaces. Therefore, 3.4 m/s² [11.2 ft/s²] (a comfortable deceleration for most drivers) is recommended as the deceleration threshold for determining stopping sight distance. Implicit in the choice of this deceleration threshold is the assessment that most vehicle braking systems and the tire-pavement friction levels of most roadways are capable of providing a deceleration of at least 3.4 m/s² [11.2 ft/s²]. The friction available on most wet pavement surfaces and the capabilities of most vehicle braking systems can provide braking friction that exceeds this deceleration rate.

Fourth paragraph: replace 1070 mm with 1080 mm and 150 mm with 600 mm

Table 3.9 is replaced by the following Table:

**Table 3.9
STOPPING SIGHT DISTANCES**

Metric					US Customary				
Design speed (km/h)	Brake reaction distance (m)	Braking distance on level (m)	Stopping sight distance		Design speed (mph)	Brake reaction distance (ft)	Braking distance on level (ft)	Stopping sight distance	
			Calculated (m)	Design (m)				Calculated (ft)	Design (ft)
20	13.9	4.6	18.5	20	15	55.1	21.6	76.7	80
30	20.9	10.3	31.2	35	20	73.5	38.4	111.9	115
40	27.8	18.4	46.2	50	25	91.9	60.0	151.9	155
50	34.8	28.7	63.5	65	30	110.3	86.4	196.7	200
60	41.7	41.3	83.0	85	35	128.6	117.6	246.2	250
70	48.7	56.2	104.9	105	40	147.0	153.6	300.6	305
80	55.6	73.4	129.0	130	45	165.4	194.4	359.8	360
90	62.6	92.9	155.5	160	50	183.8	240.0	423.8	425
100	69.5	114.7	184.2	185	55	202.1	290.3	492.4	495
110	76.5	138.8	215.3	220	60	220.5	345.5	566.0	570
120	83.4	165.2	248.6	250	65	238.9	405.5	644.4	645
130	90.4	193.8	284.2	285	70	257.3	470.3	727.6	730
					75	275.6	539.9	815.5	820
					80	294.0	614.3	908.3	910

Note: Brake reaction distance predicated on a time of 2.5 s; deceleration rate of 3.4 m/s² [11.2 ft/s²] used to determine calculated sight distance.

The computed distances for various speeds at the assumed conditions are shown in Table 3.9 and were developed from the following equation:

Metric	US Customary
$d = 0.278Vt + 0.039 \frac{V^2}{a}$	$d = 1.47Vt + 1.075 \frac{V^2}{a} \quad (3-2)$
where: t = brake reaction time, 2.5 s; V = design speed, km/h; a = deceleration rate, m/s ²	where: t = brake reaction time, 2.5 s; V = design speed, mph; a = deceleration rate, ft/s ²

Reference: "A POLICY ON GEOMETRIC DESIGN OF HIGHWAYS AND STREETS" AASHTO, 2001

First paragraph under (Table 3.9): replace formula as follows:

Metric	US Customary
$d = \frac{V^2}{254 \left(\left(\frac{a}{9.81} \right) \pm G \right)}$	$d = \frac{V^2}{30 \left(\left(\frac{a}{32.2} \right) \pm G \right)} \quad (3-3)$

Table 3.10 is replaced by the following Table:

Table 3.10
GRADE ADJUSTMENTS FOR STOPPING SIGHT DISTANCES

Metric							US Customary						
Design speed (km/h)	Stopping sight distance (m)						Design speed (mph)	Stopping sight distance (ft)					
	Downgrades			Upgrades				Downgrades			Upgrades		
	3%	6%	9%	3%	6%	9%	3%	6%	9%	3%	6%	9%	
20	20	20	20	19	18	18	15	80	82	85	75	74	73
30	32	35	35	31	30	29	20	116	120	126	109	107	104
40	50	50	53	45	44	43	25	158	165	173	147	143	140
50	66	70	74	61	59	58	30	205	215	227	200	184	179
60	87	92	97	80	77	75	35	257	271	287	237	229	222
70	110	116	124	100	97	93	40	315	333	354	289	278	269
80	136	144	154	123	118	114	45	378	400	427	344	331	320
90	164	174	187	148	141	136	50	446	474	507	405	388	375
100	194	207	223	174	167	160	55	520	553	593	469	450	433
110	227	243	262	203	194	186	60	598	638	686	538	515	495
120	263	281	304	234	223	214	65	682	728	785	612	584	561
130	302	323	350	267	254	243	70	771	825	891	690	658	631
							75	866	927	1003	772	736	704
							80	965	1035	1121	859	817	782

Reference: "A POLICY ON GEOMETRIC DESIGN OF HIGHWAYS AND STREETS" AASHTO, 2001

Table 3.11 is replaced by the following Table:

Table 3.11
DECISION SIGHT DISTANCE

Metric						US Customary					
Design speed (km/h)	Decision sight distance (m)					Design speed (mph)	Decision sight distance (ft)				
	Avoidance maneuver						Avoidance maneuver				
	A	B	C	D	E	A	B	C	D	E	
50	70	155	145	170	195	30	220	490	450	535	620
60	95	195	170	205	235	35	275	590	525	625	720
70	115	235	200	235	275	40	330	690	600	715	825
80	140	280	230	270	315	45	395	800	675	800	930
90	170	325	270	315	360	50	465	910	750	890	1030
100	200	370	315	355	400	55	535	1030	865	980	1135
110	235	420	330	380	430	60	610	1150	990	1125	1280
120	265	470	360	415	470	65	695	1275	1050	1220	1365
130	305	525	390	450	510	70	780	1410	1105	1275	1445
						75	875	1545	1180	1365	1545
						80	970	1685	1260	1455	1650

Avoidance Maneuver A: Stop on rural road— $t = 3.0$ s
 Avoidance Maneuver B: Stop on urban road— $t = 9.1$ s
 Avoidance Maneuver C: Speed/path/direction change on rural road— t varies between 10.2 and 11.2 s
 Avoidance Maneuver D: Speed/path/direction change on suburban road— t varies between 12.1 and 12.9 s
 Avoidance Maneuver E: Speed/path/direction change on urban road— t varies between 14.0 and 14.5 s

Reference: "A POLICY ON GEOMETRIC DESIGN OF HIGHWAYS AND STREETS" AASHTO, 2001

Second paragraph under (Table 3.11): replace 1070 mm with 1080 mm, and 150 mm with 600 mm

Table 3.12 is replaced by the following Table:

**Table 3.12
PASSING SIGHT DISTANCES**

Metric					US Customary				
Design speed (km/h)	Assumed speeds (km/h)		Passing sight distance (m)		Design speed (mph)	Assumed speeds (mph)		Passing sight distance (ft)	
	Passed vehicle	Passing vehicle	From Exhibit 3-6	Rounded for design		Passed vehicle	Passing vehicle	From Exhibit 3-6	Rounded for design
30	29	44	200	200	20	18	28	706	710
40	36	51	266	270	25	22	32	897	900
50	44	59	341	345	30	26	36	1088	1090
60	51	66	407	410	35	30	40	1279	1280
70	59	74	482	485	40	34	44	1470	1470
80	65	80	538	540	45	37	47	1625	1625
90	73	88	613	615	50	41	51	1832	1835
100	79	94	670	670	55	44	54	1984	1985
110	85	100	727	730	60	47	57	2133	2135
120	90	105	774	775	65	50	60	2281	2285
130	94	109	812	815	70	54	64	2479	2480
					75	56	66	2578	2580
					80	58	68	2677	2680

Reference: "A POLICY ON GEOMETRIC DESIGN OF HIGHWAYS AND STREETS" AASHTO, 2001

Figure 3.4 is replaced by the following Figure:

Figure 3-4 SCALING AND RECORDING SIGHT DISTANCES ON PLANS

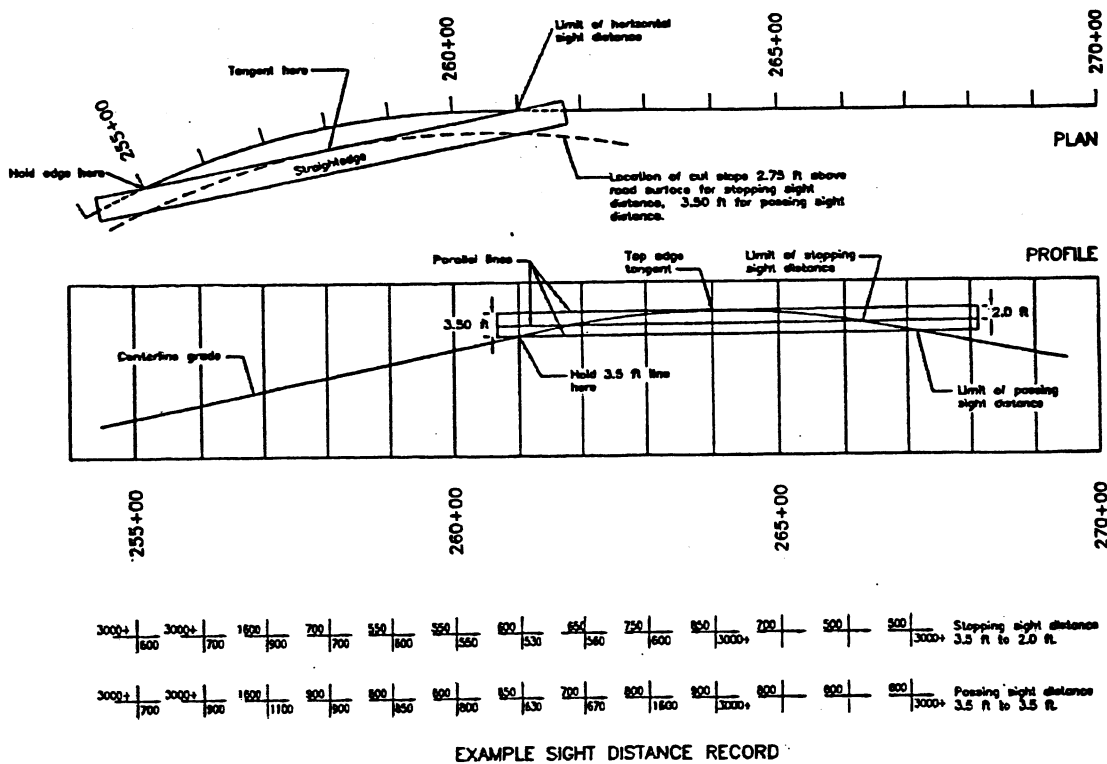
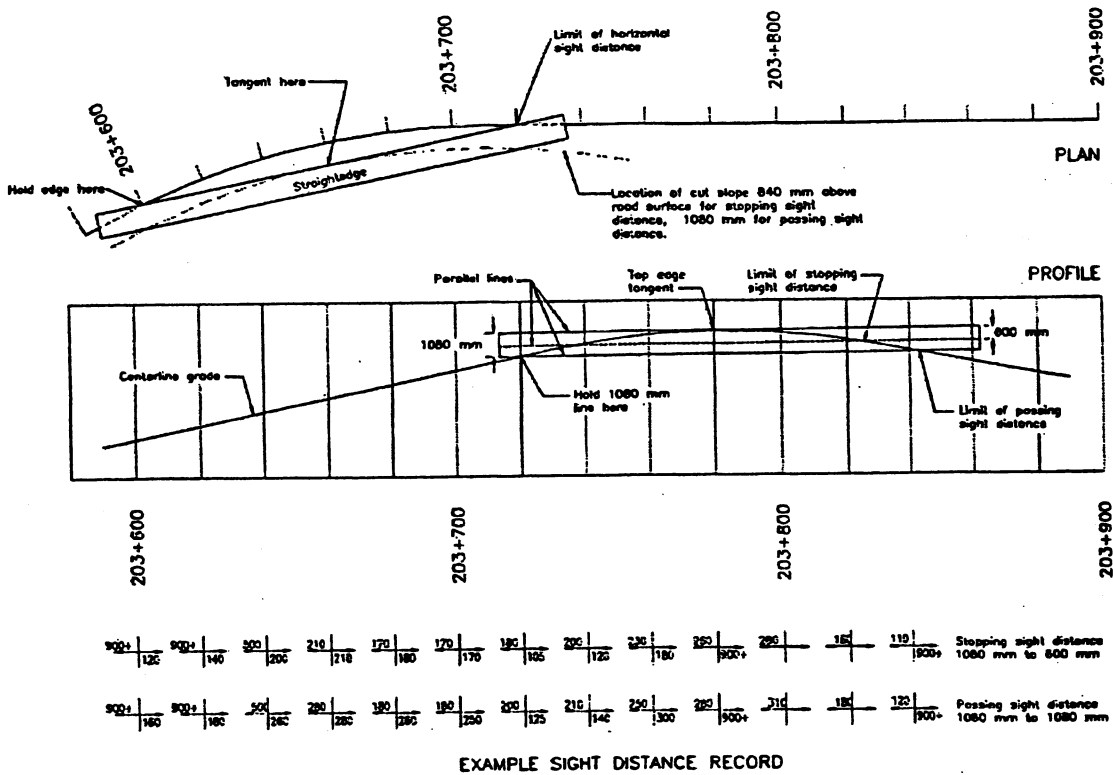

Table 4.2 is replaced by the following Table:

Table 4.2
MINIMUM RADIUS FOR DESIGN OF RURAL HIGHWAYS, URBAN FREEWAYS,
AND HIGH-SPEED URBAN STREETS USING LIMITING VALUES OF e AND f

Metric						US Customary					
Design Speed (km/h)	Maximum e (%)	Limiting Values of f	Total (e/100 + f)	Calculated Radius (m)	Rounded Radius (m)	Design Speed (mph)	Maximum e (%)	Limiting Values of f	Total (e/100 + f)	Calculated Radius (ft)	Rounded Radius (ft)
20	4.0	0.18	0.22	14.3	15	15	4.0	0.175	0.215	70.0	70
30	4.0	0.17	0.21	33.7	35	20	4.0	0.170	0.210	127.4	125
40	4.0	0.17	0.21	60.0	60	25	4.0	0.165	0.205	203.9	205
50	4.0	0.16	0.20	98.4	100	30	4.0	0.160	0.200	301.0	300
60	4.0	0.15	0.19	149.1	150	35	4.0	0.155	0.195	420.2	420
70	4.0	0.14	0.18	214.2	215	40	4.0	0.150	0.190	563.3	565
80	4.0	0.14	0.18	279.8	280	45	4.0	0.145	0.185	732.2	730
90	4.0	0.13	0.17	375.0	375	50	4.0	0.140	0.180	929.0	930
100	4.0	0.12	0.16	491.9	490	55	4.0	0.130	0.170	1190.2	1190
						60	4.0	0.120	0.160	1505.0	1505
20	6.0	0.18	0.24	13.1	15	15	6.0	0.175	0.235	64.0	65
30	6.0	0.17	0.23	30.8	30	20	6.0	0.170	0.230	116.3	115
40	6.0	0.17	0.23	54.7	55	25	6.0	0.165	0.225	185.8	185
50	6.0	0.16	0.22	89.4	90	30	6.0	0.160	0.220	273.6	275
60	6.0	0.15	0.21	134.9	135	35	6.0	0.155	0.215	381.1	380
70	6.0	0.14	0.20	192.8	195	40	6.0	0.150	0.210	509.6	510
80	6.0	0.14	0.20	251.8	250	45	6.0	0.145	0.205	660.7	660
90	6.0	0.13	0.19	335.5	335	50	6.0	0.140	0.200	836.1	835
100	6.0	0.12	0.18	437.2	435	55	6.0	0.130	0.190	1065.0	1065
110	6.0	0.11	0.17	560.2	560	60	6.0	0.120	0.180	1337.8	1340
120	6.0	0.09	0.15	755.5	755	65	6.0	0.110	0.170	1662.4	1660
130	6.0	0.08	0.14	950.0	950	70	6.0	0.100	0.160	2048.5	2050
						75	6.0	0.090	0.150	2508.4	2510
						80	6.0	0.080	0.140	3057.8	3060

Note: In recognition of safety considerations, use of $e_{max} = 4.0\%$ should be limited to urban conditions.

Reference: "A POLICY ON GEOMETRIC DESIGN OF HIGHWAYS AND STREETS" AASHTO, 2001

Replace the fifth paragraph with the following:

1. Figures 4-6, 4-7 and 4-9 provide the criteria for stopping sight distance. The height of eye is 1080 millimeters and the height of object is 600 millimeters. The line-of-sight intercept with the view obstruction is at the midpoint of the sight line and 840 millimeters above the center of the inside lane.

Figures 4-6 and 4-7 are replaced by the following Figure:

Figure 4-6
DESIGN CONTROLS FOR STOPPING SIGHT DISTANCE ON HORIZONTAL CURVES

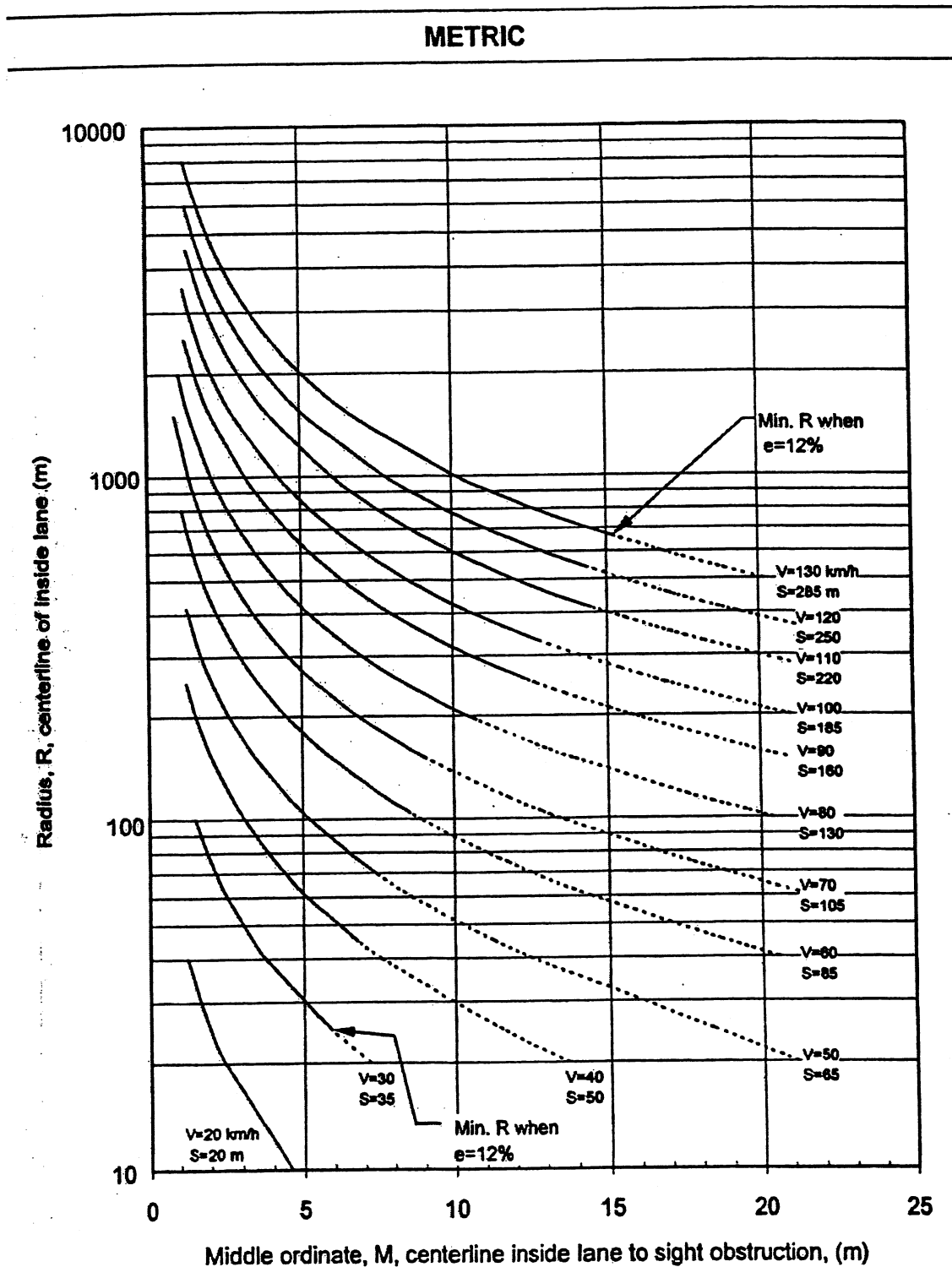

Figure 4-6
DESIGN CONTROLS FOR STOPPING SIGHT DISTANCE ON HORIZONTAL
CURVES (CONTINUED)

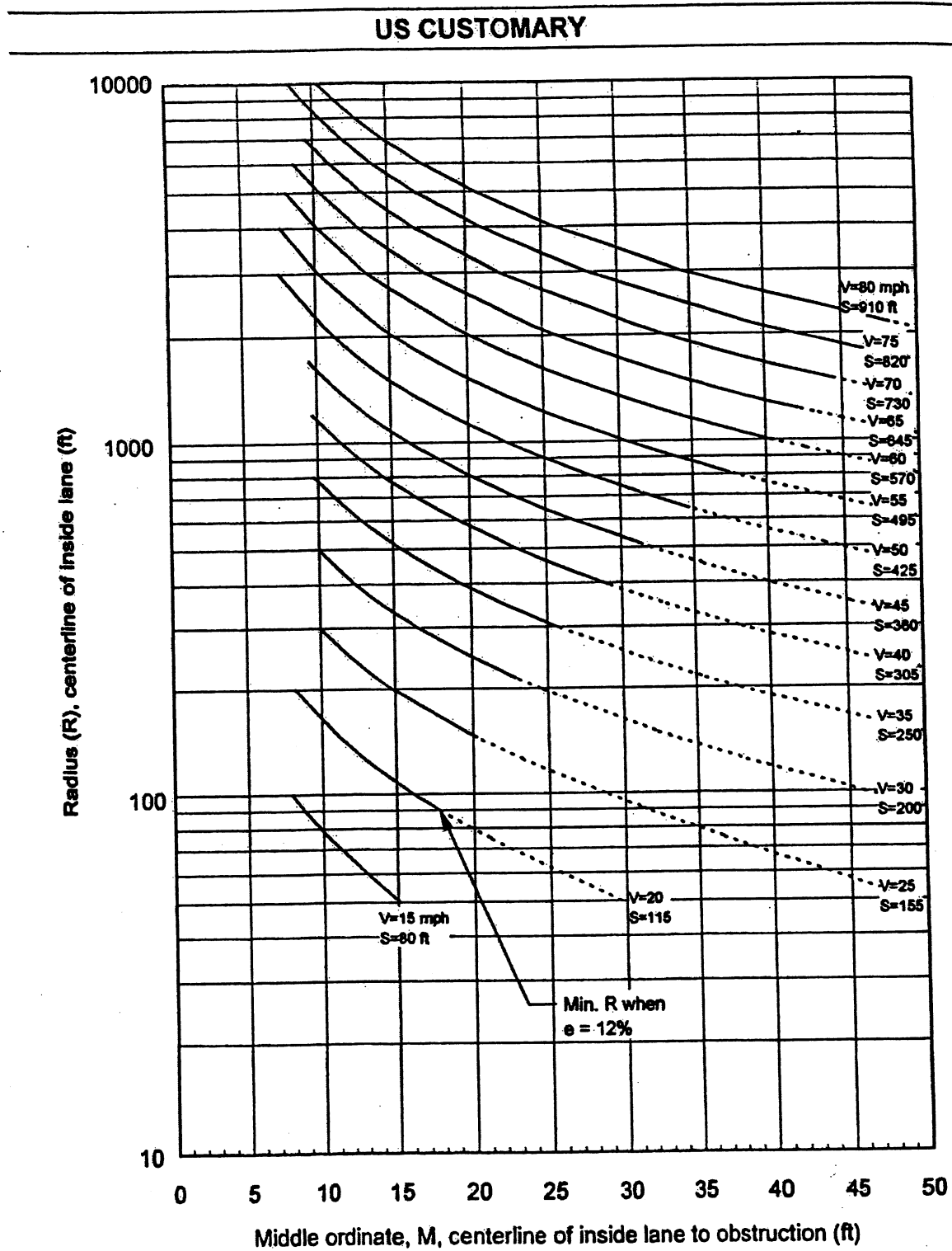
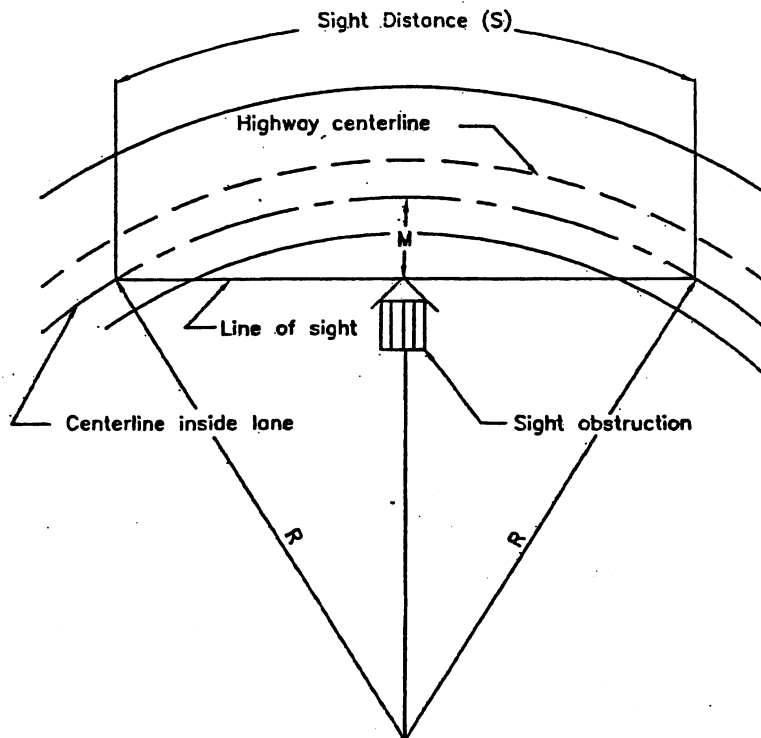

Figure 4-8: replace 610 mm with 840 mm

Add the following Figure 4-9

Figure 4-9

DIAGRAM ILLUSTRATING COMPONENTS FOR DETERMINING HORIZONTAL SIGHT DISTANCE



Reference: "A POLICY ON GEOMETRIC DESIGN OF HIGHWAYS AND STREETS" AASHTO, 2001

Table 4.3 is replaced with the following Table:

**Table 4.3
MAXIMUM GRADES FOR RURAL AND URBAN FREEWAYS**

Type of Terrain	Metric						US Customary						
	Design Speeds (km/h)						Design Speeds (mph)						
	80	90	100	110	120	130	50	55	60	65	70	75	80
	Grades (%) ^a						Grades (%) ^a						
Level	4	4	3	3	3	3	4	4	3	3	3	3	3
Rolling	5	5	4	4	4	4	5	5	4	4	4	4	4
Mountainous	6	6	6	5	-	-	6	6	6	5	5	-	-

^a Grades 1% steeper than the value shown may be provided in mountainous terrain or in urban areas with crucial right-of way controls.

MAXIMUM GRADES FOR URBAN ARTERIALS

Type of terrain	Metric						US Customary						
	Maximum grade (%) for specified design speed (km/h)						Maximum grade (%) for specified design speed (mph)						
	50	60	70	80	90	100	30	35	40	45	50	55	60
Level	8	7	6	6	5	5	8	7	7	6	6	5	5
Rolling	9	8	7	7	6	6	9	8	8	7	7	6	6
Mountainous	11	10	9	9	8	8	11	10	10	9	9	8	8

MAXIMUM GRADES FOR RURAL ARTERIALS

Type of terrain	Metric								US Customary								
	Maximum grade (%) for specified design speed (km/h)								Maximum grade (%) for specified design speed (mph)								
	60	70	80	90	100	110	120	130	40	45	50	55	60	65	70	75	80
Level	5	5	4	4	3	3	3	3	5	5	4	4	3	3	3	3	3
Rolling	6	6	5	5	4	4	4	4	6	6	5	5	4	4	4	4	4
Mountainous	8	7	7	6	6	5	5	5	8	7	7	6	6	5	5	5	5

Table 4.3 (CONTINUED)

MAXIMUM GRADES FOR URBAN COLLECTORS

Type of terrain	Metric									US Customary								
	Maximum grade (%) for specified design speed (km/h)									Maximum grade (%) for specified design speed (mph)								
	30	40	50	60	70	80	90	100		20	25	30	35	40	45	50	55	60
Level	9	9	9	9	8	7	7	6		9	9	9	9	9	8	7	7	6
Rolling	12	12	11	10	9	8	8	7		12	12	11	10	10	9	8	8	7
Mountainous	14	13	12	12	11	10	10	9		14	13	12	12	12	11	10	10	9

Note: Short lengths of grade in urban areas, such as grades less than 150 m [500 ft] in length, one-way downgrades, and grades on low-volume urban collectors may be up to 2 percent steeper than the grades shown above.

MAXIMUM GRADES FOR RURAL COLLECTORS

Type of terrain	Metric									US Customary								
	Maximum grade (%) for specified design speed (km/h)									Maximum grade (%) for specified design speed (mph)								
	30	40	50	60	70	80	90	100		20	25	30	35	40	45	50	55	60
Level	7	7	7	7	7	6	6	5		7	7	7	7	7	7	6	6	5
Rolling	10	10	9	8	8	7	7	6		10	10	9	9	8	8	7	7	6
Mountainous	12	11	10	10	10	9	9	8		12	11	10	10	10	10	9	9	8

Note: Short lengths of grade in rural areas, such as grades less than 150 m [500 ft] in length, one-way downgrades, and grades on low-volume rural collectors may be up to 2 percent steeper than the grades shown above.

MAXIMUM GRADES FOR LOCAL RURAL ROADS

Type of terrain	Metric									US Customary								
	Maximum grade (%) for specified design speed (km/h)									Maximum grade (%) for specified design speed (mph)								
	20	30	40	50	60	70	80	90	100	15	20	25	30	40	45	50	55	60
Level	9	8	7	7	7	7	6	6	5	9	8	7	7	7	7	6	6	5
Rolling	12	11	11	10	10	9	8	7	6	12	11	11	10	10	9	8	7	6
Mountainous	17	16	15	14	13	12	10	10	-	17	16	15	14	13	12	10	10	-

GRADES FOR LOCAL URBAN STREETS

Grades for local residential streets should be as level as practical, consistent with the surrounding terrain. The gradient for local streets should be less than 15 percent. Where grades of 4 percent or steeper are necessary, the drainage design may become critical. On such grades special care should be taken to prevent erosion on slopes and open drainage facilities.

For streets in commercial and industrial areas, gradient design desirably should be less than 8 percent, grades should desirably be less than 5 percent, and flatter grades should be encouraged.

To provide for proper drainage, the desirable minimum grade for streets with outer curbs should be 0.30 percent, but a minimum grade of 0.20 percent may be used.

Figure 4-9 is replaced with the following Figure:

FIGURE 4-9
CRITICAL LENGTHS OF GRADE FOR DESIGN, ASSUMED TYPICAL HEAVY TRUCK OF 120 kg/kW [200 lb/hp], ENTERING SPEED=110 km/h [70 mph]

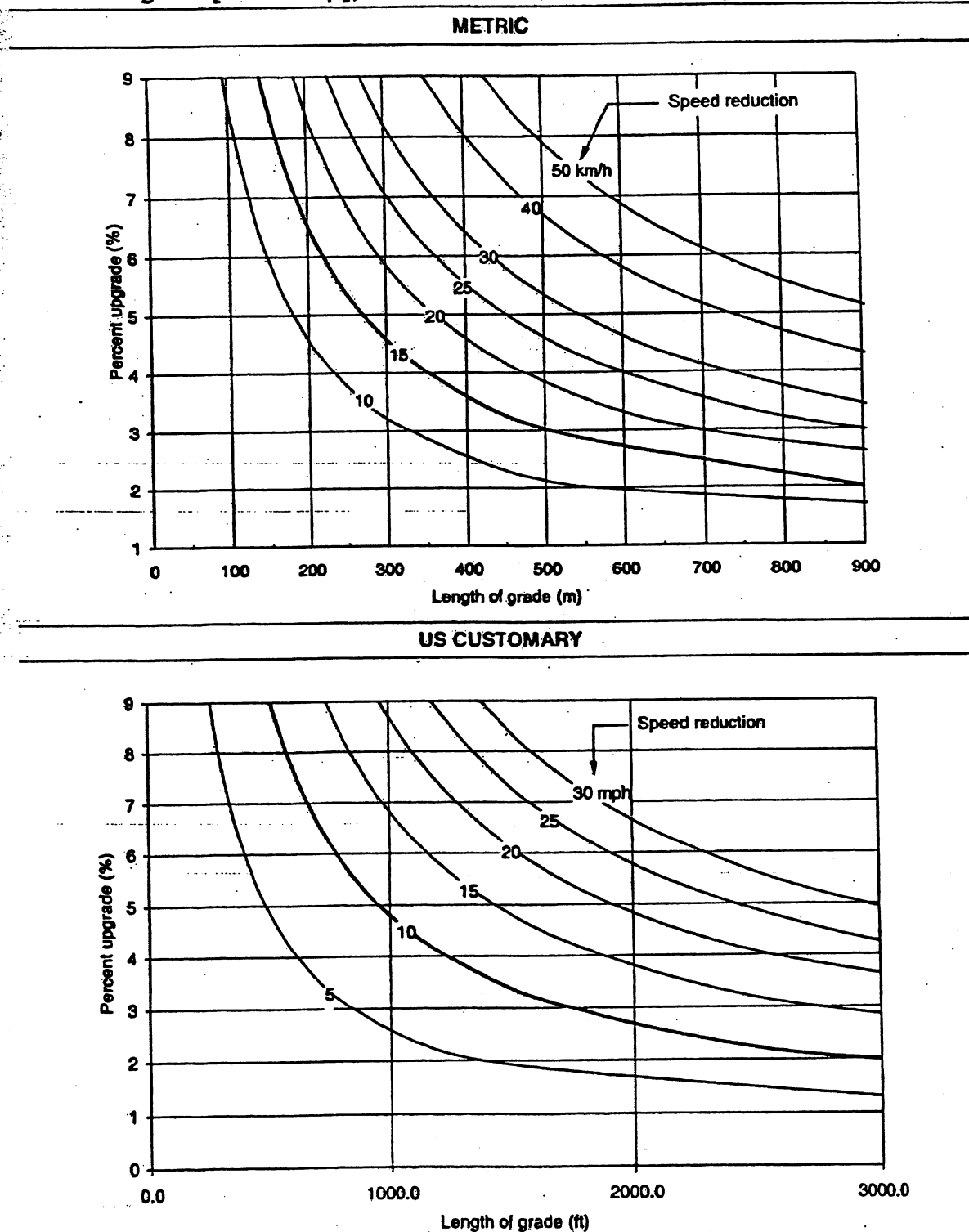

Table 4.4 is replaced with the following Table:

Table 4.4
DESIGN CONTROLS FOR STOPPING SIGHT DISTANCE FOR CREST VERTICAL CURVES

Metric				US Customary			
Design speed (km/h)	Stopping sight distance (m)	Rate of vertical curvature, K ^a		Design speed (mph)	Stopping sight distance (ft)	Rate of vertical curvature, K ^a	
		Calculated	Design			Calculated	Design
20	20	0.6	1	15	80	3.0	3
30	35	1.9	2	20	115	6.1	7
40	50	3.8	4	25	155	11.1	12
50	65	6.4	7	30	200	18.5	19
60	85	11.0	11	35	250	29.0	29
70	105	16.8	17	40	305	43.1	44
80	130	25.7	26	45	360	60.1	61
90	160	38.9	39	50	425	83.7	84
100	185	52.0	52	55	495	113.5	114
110	220	73.6	74	60	570	150.6	151
120	250	95.0	95	65	645	192.8	193
130	285	123.4	124	70	730	246.9	247
				75	820	311.6	312
				80	910	383.7	384

^a Rate of vertical curvature, K, is the length of curve per percent algebraic difference in intersecting grades (A). $K = L/A$

Reference: "A POLICY ON GEOMETRIC DESIGN OF HIGHWAYS AND STREETS" AASHTO, 2001

Add the following Paragraph:

Designer should check the sight distance under bridges.

Table 4.5 is replaced with the following Table:

Table 4.5
DESIGN CONTROLS FOR SAG VERTICAL CURVES

Metric				US Customary			
Design speed (km/h)	Stopping sight distance (m)	Rate of vertical curvature, K ^a		Design speed (mph)	Stopping sight distance (ft)	Rate of vertical curvature, K ^a	
		Calculated	Design			Calculated	Design
20	20	2.1	3	15	80	9.4	10
30	35	5.1	6	20	115	16.5	17
40	50	8.5	9	25	155	25.5	26
50	65	12.2	13	30	200	36.4	37
60	85	17.3	18	35	250	49.0	49
70	105	22.6	23	40	305	63.4	64
80	130	29.4	30	45	360	78.1	79
90	160	37.6	38	50	425	95.7	96
100	185	44.6	45	55	495	114.9	115
110	220	54.4	55	60	570	135.7	136
120	250	62.8	63	65	645	156.5	157
130	285	72.7	73	70	730	180.3	181
				75	820	205.6	206
				80	910	231.0	231

^a Rate of vertical curvature, K, is the length of curve (m) per percent algebraic difference intersecting grades (A). $K = L/A$

Reference: "A POLICY ON GEOMETRIC DESIGN OF HIGHWAYS AND STREETS" AASHTO, 2001

Table 4.7 (CONTINUED)
VALUES FOR DESIGN ELEMENTS RELATED TO DESIGN SPEED AND HORIZONTAL CURVATURE

US CUSTOMARY

R (ft)	V _d = 15 mph		V _d = 20 mph		V _d = 25 mph		V _d = 30 mph		V _d = 35 mph		V _d = 40 mph		V _d = 45 mph		V _d = 50 mph		V _d = 55 mph		V _d = 60 mph		V _d = 65 mph		V _d = 70 mph		V _d = 75 mph		V _d = 80 mph		
	L (ft)	Ln (%)	L (ft)	Ln (%)	L (ft)	Ln (%)	L (ft)	Ln (%)	L (ft)	Ln (%)	L (ft)	Ln (%)	L (ft)	Ln (%)	L (ft)	Ln (%)	L (ft)	Ln (%)	L (ft)	Ln (%)	L (ft)	Ln (%)	L (ft)	Ln (%)	L (ft)	Ln (%)	L (ft)	Ln (%)	
23000	0	0	0	0	0	0	0	0	0	0	0	0	0	0	0	0	0	0	0	0	0	0	0	0	0	0	0	0	0
20000	0	0	0	0	0	0	0	0	0	0	0	0	0	0	0	0	0	0	0	0	0	0	0	0	0	0	0	0	0
17000	0	0	0	0	0	0	0	0	0	0	0	0	0	0	0	0	0	0	0	0	0	0	0	0	0	0	0	0	0
14000	0	0	0	0	0	0	0	0	0	0	0	0	0	0	0	0	0	0	0	0	0	0	0	0	0	0	0	0	0
12000	0	0	0	0	0	0	0	0	0	0	0	0	0	0	0	0	0	0	0	0	0	0	0	0	0	0	0	0	0
10000	0	0	0	0	0	0	0	0	0	0	0	0	0	0	0	0	0	0	0	0	0	0	0	0	0	0	0	0	0
8000	0	0	0	0	0	0	0	0	0	0	0	0	0	0	0	0	0	0	0	0	0	0	0	0	0	0	0	0	0
6000	0	0	0	0	0	0	0	0	0	0	0	0	0	0	0	0	0	0	0	0	0	0	0	0	0	0	0	0	0
5000	0	0	0	0	0	0	0	0	0	0	0	0	0	0	0	0	0	0	0	0	0	0	0	0	0	0	0	0	0
4000	0	0	0	0	0	0	0	0	0	0	0	0	0	0	0	0	0	0	0	0	0	0	0	0	0	0	0	0	0
3500	0	0	0	0	0	0	0	0	0	0	0	0	0	0	0	0	0	0	0	0	0	0	0	0	0	0	0	0	0
3000	0	0	0	0	0	0	0	0	0	0	0	0	0	0	0	0	0	0	0	0	0	0	0	0	0	0	0	0	0
2500	0	0	0	0	0	0	0	0	0	0	0	0	0	0	0	0	0	0	0	0	0	0	0	0	0	0	0	0	0
2000	0	0	0	0	0	0	0	0	0	0	0	0	0	0	0	0	0	0	0	0	0	0	0	0	0	0	0	0	0
1800	0	0	0	0	0	0	0	0	0	0	0	0	0	0	0	0	0	0	0	0	0	0	0	0	0	0	0	0	0
1600	0	0	0	0	0	0	0	0	0	0	0	0	0	0	0	0	0	0	0	0	0	0	0	0	0	0	0	0	0
1400	0	0	0	0	0	0	0	0	0	0	0	0	0	0	0	0	0	0	0	0	0	0	0	0	0	0	0	0	0
1200	0	0	0	0	0	0	0	0	0	0	0	0	0	0	0	0	0	0	0	0	0	0	0	0	0	0	0	0	0
1000	0	0	0	0	0	0	0	0	0	0	0	0	0	0	0	0	0	0	0	0	0	0	0	0	0	0	0	0	0
900	0	0	0	0	0	0	0	0	0	0	0	0	0	0	0	0	0	0	0	0	0	0	0	0	0	0	0	0	0
800	0	0	0	0	0	0	0	0	0	0	0	0	0	0	0	0	0	0	0	0	0	0	0	0	0	0	0	0	0
700	0	0	0	0	0	0	0	0	0	0	0	0	0	0	0	0	0	0	0	0	0	0	0	0	0	0	0	0	0
600	0	0	0	0	0	0	0	0	0	0	0	0	0	0	0	0	0	0	0	0	0	0	0	0	0	0	0	0	0
500	0	0	0	0	0	0	0	0	0	0	0	0	0	0	0	0	0	0	0	0	0	0	0	0	0	0	0	0	0
450	0	0	0	0	0	0	0	0	0	0	0	0	0	0	0	0	0	0	0	0	0	0	0	0	0	0	0	0	0
400	0	0	0	0	0	0	0	0	0	0	0	0	0	0	0	0	0	0	0	0	0	0	0	0	0	0	0	0	0
350	0	0	0	0	0	0	0	0	0	0	0	0	0	0	0	0	0	0	0	0	0	0	0	0	0	0	0	0	0
300	0	0	0	0	0	0	0	0	0	0	0	0	0	0	0	0	0	0	0	0	0	0	0	0	0	0	0	0	0
250	0	0	0	0	0	0	0	0	0	0	0	0	0	0	0	0	0	0	0	0	0	0	0	0	0	0	0	0	0
200	0	0	0	0	0	0	0	0	0	0	0	0	0	0	0	0	0	0	0	0	0	0	0	0	0	0	0	0	0
150	0	0	0	0	0	0	0	0	0	0	0	0	0	0	0	0	0	0	0	0	0	0	0	0	0	0	0	0	0
100	0	0	0	0	0	0	0	0	0	0	0	0	0	0	0	0	0	0	0	0	0	0	0	0	0	0	0	0	0
75	0	0	0	0	0	0	0	0	0	0	0	0	0	0	0	0	0	0	0	0	0	0	0	0	0	0	0	0	0

E_{max} = 6%
 R = radius of curve
 V_d = assumed design speed
 e = rate of superelevation
 L = minimum length of runoff (does not include tangent runoff) as discussed in "Tangent-to-Curve Transition" section
 NC = normal crown section
 RC = remove adverse crown, superelevate at normal crown slope

Reference: "A POLICY ON GEOMETRIC DESIGN OF HIGHWAYS AND STREETS" AASHTO, 2001

Table 4.8 is replaced with the following Table:

Table 4.8
MAXIMUM RELATIVE GRADIENTS

Metric			US Customary		
Design speed (km/h)	Maximum relative gradient (%)	Equivalent maximum relative slope	Design speed (mph)	Maximum relative gradient (%)	Equivalent maximum relative slope
20	0.80	1:125	15	0.78	1:128
30	0.75	1:133	20	0.74	1:135
40	0.70	1:143	25	0.70	1:143
50	0.65	1:150	30	0.66	1:152
60	0.60	1:167	35	0.62	1:161
70	0.55	1:182	40	0.58	1:172
80	0.50	1:200	45	0.54	1:185
90	0.47	1:213	50	0.50	1:200
100	0.44	1:227	55	0.47	1:213
110	0.41	1:244	60	0.45	1:222
120	0.38	1:263	65	0.43	1:233
130	0.35	1:286	70	0.40	1:250
			75	0.38	1:263
			80	0.35	1:286

Reference: "A POLICY ON GEOMETRIC DESIGN OF HIGHWAYS AND STREETS" AASHTO, 2001

Second paragraph: replace 0.25 meters with **0.30** meters

Replace the title above in parenthesis: 60 km/h with **70 km/h**

Table 4.9 is replaced with the following Table:

Table 4.9

MINIMUM RADII AND MINIMUM LENGTHS OF SUPERELEVATION RUNOFF FOR LIMITING VALUES OF e AND f (LOW-SPEED URBAN STREETS)

Metric													
Design speed (km/h)	Max e/100	Max f	Total (e/100 + f)	Min R (m)	Max e/100	Max f	Total (e/100 + f)	Min R (m)	Max e/100	Max f	Total (e/100 + f)	Min R (m)	C
20	0.06	0.350	0.410	10	0.04	0.350	0.390	10	0.00	0.350	0.350	10	1.25
30	0.06	0.312	0.372	20	0.04	0.312	0.352	20	0.00	0.312	0.312	25	1.20
40	0.06	0.252	0.312	40	0.04	0.252	0.292	45	0.00	0.252	0.252	50	1.15
50	0.06	0.214	0.274	70	0.04	0.214	0.254	80	0.00	0.214	0.214	90	1.10
60	0.06	0.186	0.246	115	0.04	0.186	0.226	125	0.00	0.186	0.186	150	1.05
70	0.06	0.163	0.223	175	0.04	0.163	0.203	190	0.00	0.163	0.163	235	1.00
US Customary													
Design speed (mph)	Max e/100	Max f	Total (e/100 + f)	Min R (ft)	Max e/100	Max f	Total (e/100 + f)	Min R (ft)	Max e/100	Max f	Total (e/100 + f)	Min R (ft)	C
15	0.06	0.330	0.390	40	0.04	0.330	0.370	40	0.00	0.330	0.330	45	4.25
20	0.06	0.300	0.360	75	0.04	0.300	0.340	80	0.00	0.300	0.300	90	4.00
25	0.06	0.252	0.312	135	0.04	0.252	0.292	145	0.00	0.252	0.252	165	3.75
30	0.06	0.221	0.281	215	0.04	0.221	0.261	230	0.00	0.221	0.221	275	3.50
35	0.06	0.197	0.257	320	0.04	0.197	0.231	345	0.00	0.197	0.197	415	3.25
40	0.06	0.178	0.238	450	0.04	0.178	0.218	490	0.00	0.178	0.178	600	3.00
45	0.06	0.163	0.223	605	0.04	0.163	0.203	665	0.00	0.163	0.163	830	2.75

Reference: "A POLICY ON GEOMETRIC DESIGN OF HIGHWAYS AND STREETS" AASHTO, 2001

Table 5.1 is replaced with the following Tables on the next pages:

**Table 5.1
RECOMMENDED ROADWAY SECTION WIDTHS**

**FREEWAYS
English Units (feet)**

TRAVEL MINIMUM LANE WIDTH	PAVED RIGHT USABLE SHOULDER WIDTH MIN.	LEFT USABLE SHOULDER W/ 6 OR MORE LANES DESIRABLE WIDTH	LEFT USABLE SHOULDER W/ 4 TRAVEL LANES DESIRABLE WIDTH	LEFT USABLE SHOULDER WIDTH MINIMUM
12 FT.	10 FT. (12 FT.*)	10 FT. (12 FT.*)	8 FT. (10 FT.*)	4 FT.

Metric Units (meters)

TRAVEL MINIMUM LANE WIDTH	PAVED RIGHT USABLE SHOULDER WIDTH MIN.	LEFT USABLE SHOULDER W/ 6 OR MORE LANES DESIRABLE WIDTH	LEFT USABLE SHOULDER W/ 4 TRAVEL LANES DESIRABLE WIDTH	LEFT USABLE SHOULDER WIDTH MINIMUM
3.66 m	3.05 m (3.66 m*)	3.05 m (3.66 m*)	2.44m (3.05 m*)	1.22 m

* With truck volumes over 250 vehicles/day

Note: 2 ft. (610 mm) added to usable shoulder width for minimum offset to vertical elements over 8" (200 mm) high.

**ARTERIALS
English Units (feet)**

MIN. LANE WIDTH (FT) FOR DESIGN VOLUME (VEH/DAY)

DESIGN SPEED	UNDER 400	400 TO 1500	1500 TO 2000	OVER-2000
30 mph	11 Ft.	11 Ft.	11 Ft.	12 Ft.
35 mph	11 Ft.	11 Ft.	11 Ft.	12 Ft.
40 mph	11 Ft.	11 Ft.	11 Ft.	12 Ft.
45 mph	11 Ft.	11 Ft.	11 Ft.	12 Ft.
50 mph	11 Ft.	11 Ft.	12 Ft.	12 Ft.
55 mph	11 Ft.	11 Ft.	12 Ft.	12 Ft.
60 mph	12 Ft.	12 Ft.	12 Ft.	12 Ft.
65 mph	12 Ft.	12 Ft.	12 Ft.	12 Ft.
70 mph	12 Ft.	12 Ft.	12 Ft.	12 Ft.
75 mph	12 Ft.	12 Ft.	12 Ft.	12 Ft.

MINIMUM WIDTH OF USABLE SHOULDER (FT)*

ALL SPEEDS	4 Ft.	6 Ft.	6 Ft.	8 Ft.
-------------------	-------	-------	-------	-------

Metric Units (meters)

MIN. LANE WIDTH (m) FOR DESIGN VOLUME (VEH/DAY)

DESIGN SPEED	UNDER 400	400 TO 1500	1500 TO 2000	OVER-2000
50 km/h	3.35 m	3.35 m	3.35 m	3.66 m
55 km/h	3.35 m	3.35 m	3.35 m	3.66 m
60 km/h	3.35 m	3.35 m	3.35 m	3.66 m
70 km/h	3.35 m	3.35 m	3.35 m	3.66 m
80 km/h	3.35 m	3.35 m	3.66 m	3.66 m
90 km/h	3.35 m	3.35 m	3.66 m	3.66 m
100 km/h	3.66 m	3.66 m	3.66 m	3.66 m
105km/h	3.66 m	3.66 m	3.66 m	3.66 m
110 km/h	3.66 m	3.66 m	3.66 m	3.66 m
120 km/h	3.66 m	3.66 m	3.66 m	3.66 m

MINIMUM WIDTH OF USABLE SHOULDER (m)*

ALL SPEEDS	1.22 m	1.83 m	1.83 m	2.44 m
-------------------	--------	--------	--------	--------

* 2 ft. (610 mm) added to usable shoulder width for minimum offset to vertical elements over 8" (200 mm) high.

COLLECTORS* & LOCAL ROADS*
Minimum Lane Widths/Shoulder Widths for Design Volume (VEH/DAY)

English Units (feet)

DESIGN SPEED		UNDER 100	100-250	251-400	401-1500	1501-2000	OVER 2000
15 mph	Ft	9/0	9/0	10 [9]/0	10/3 (1.5)	10/3 (3)	12 [11]/8 (4)
20 mph	Ft	9/0	9/0	10 [9]/0	10/3 (1.5)	10/3 (3)	12 [11]/8 (4)
25 mph	Ft	9/0	9/0	10 [9]/0	10/3 (1.5)	10/3 (3)	12/8 (4)
30 mph	Ft	9/0	9/0	10 [9]/0	11 [10]/3 (1.5)	11/3 (3)	12/8 (4)
35 mph	Ft	9/0	9/0	10 [9]/3 (1.5)	11 [10]/3 (1.5)	11/3 (3)	12/8 (4)
40 mph	Ft	9/1.5 (1.5)	10 [9]/3 (1.5)	10 [9]/3 (1.5)	11 [10]/3 (1.5)	11/4 (3)	12/8 (4)
45 mph	Ft	9/2 (1.5)	10/3 (1.5)	10/3 (1.5)	11/4 (1.5)	11/6 (3)	12/8 (4)
50 mph	Ft	10/2 (2)	10/2 (2)	10/2 (2)	11/4 (3)	12/6 (4)	12/8 (4)
55 mph	Ft	11/2 (2)	11/2 (2)	11/2 (2)	11/4 (3)	12/6 (4)	12/8 (4)
60 mph	Ft	11/2 (2)	11/2 (2)	11/2 (2)	11/4 (3)	12/6 (4)	12/8 (4)

Metric Units (meters)

DESIGN SPEED		UNDER 100	100-250	251-400	401-1500	1501-2000	OVER 2000
20 km/h	m	2.74/0	2.74/0	3.05 [2.74]/0	3.05/.91 (.46)	3.05/.91 (.91)	3.66 [3.35]/2.44 (1.22)
30 km/h	m	2.74/0	2.74/0	3.05 [2.74]/0	3.05/.91 (.46)	3.05/.91 (.91)	3.66 [3.35]/2.44 (1.22)
40 km/h	m	2.74/0	2.74/0	3.05 [2.74]/0	3.05/.91 (.46)	3.05/.91 (.91)	3.66/2.44 (1.22)
50 km/h	m	2.74/0	2.74/0	3.05 [2.74]/0	3.35 [3.05]/.91 (.46)	3.35/.91 (.91)	3.66/2.44 (1.22)
55 km/h	m	2.74/0	2.74/0	3.05 [2.74]/.91 (.46)	3.35 [3.05]/.91 (.46)	3.35/.91 (.91)	3.66/2.44 (1.22)
60 km/h	m	2.74/.46 (.46)	3.05 [2.74]/.91 (.46)	3.05 [2.74]/.91 (.46)	3.35 [3.05]/.91 (.46)	3.35/1.22 (.91)	3.66/2.44 (1.22)
70 km/h	m	2.74/.61 (.46)	3.05/.91 (.46)	3.05/.91 (.46)	3.35/1.22 (.46)	3.35/1.83 (.91)	3.66/2.44 (1.22)
80 km/h	m	3.05/.61 (.61)	3.05/.61 (.61)	3.05/.61 (.61)	3.35/1.22 (.91)	3.66/1.83 (1.22)	3.66/2.44 (1.22)
90 km/h	m	3.35/.61 (.61)	3.35/.61 (.61)	3.35/.61 (.61)	3.35/1.22 (.91)	3.66/1.83 (1.22)	3.66/2.44 (1.22)
100 km/h	m	3.35/.61 (.61)	3.35/.61 (.61)	3.35/.61 (.61)	3.35/1.22 (.91)	3.66/1.83 (1.22)	3.66/2.44 (1.22)

- Notes: 1. 4 ft. (1.22m) min. offset from travelway to vertical barrier over 8 in. (200 mm) high.
 2. 1 ft. (310 mm) min. 2 ft. (610 mm) desirable offset from travelway to vertical curb.
 3. 2 ft. (610 mm) min. offset from usable shoulder to vertical barrier over 8 in. (200 mm) high.
 4. () = Minimum paved shoulder for bicycle accommodation.
 5. [] = Local Road minimum travel lane.

* This table incorporates MassHighway Low Speed/Low Volume Roadway Standards for Collectors and Local Roads.

Page 5.12.0 through Page 5.34.0

Figure 5.2 through Figure 5.14: Replace lane and shoulder widths with values from Table 5.1

Page 5.35

Section 5.9

APPENDIX

Delete Curbs table

Page 6.29.0

Section 6.5.1.2

Deceleration Lanes

First paragraph: replace Table 6.2 with **Table 6.3**

Table 6.1 is replaced with the following Table:

TABLE 6.1
MINIMUM DECELERATION LENGTHS FOR EXIT TERMINALS WITH FLAT GRADES OF 2 PERCENT OR LESS

Metric									
Deceleration length, L (m) for design speed of exit curve V' (km/h)									
Highway design speed, V (km/h)	Speed reached, V _a (km/h)	Stop condition	20	30	40	50	60	70	80
		For average running speed on exit curve V' _a (km/h)							
		0	20	28	35	42	51	63	70
50	47	75	70	60	45	-	-	-	-
60	55	95	90	80	65	55	-	-	-
70	63	110	105	95	85	70	55	-	-
80	70	130	125	115	100	90	80	55	-
90	77	145	140	135	120	110	100	75	60
100	85	170	165	155	145	135	120	100	85
110	91	180	180	170	160	150	140	120	105
120	98	200	195	185	175	170	155	140	120

V = design speed of highway (km/h)
 V_a = average running speed on highway (km/h)
 V' = design speed of exit curve (km/h)
 V'_a = average running speed on exit curve (km/h)

US Customary										
Deceleration length, L (ft) for design speed of exit curve, V' (mph)										
Highway design speed, V (mph)	Speed reached, V _a (mph)	Stop condition	15	20	25	30	35	40	45	50
		For average running speed on exit curve, V' _a (mph)								
		0	14	18	22	26	30	36	40	44
30	28	235	200	170	140	-	-	-	-	-
35	32	280	250	210	185	150	-	-	-	-
40	36	320	295	265	235	185	155	-	-	-
45	40	385	350	325	295	250	220	-	-	-
50	44	435	405	385	355	315	285	225	175	-
55	48	480	455	440	410	380	350	285	235	-
60	52	530	500	480	460	430	405	350	300	240
65	55	570	540	520	500	470	440	390	340	280
70	58	615	590	570	550	520	490	440	390	340
75	61	660	635	620	600	575	535	490	440	390

V = design speed of highway (mph)
 V_a = average running speed on highway (mph)
 V' = design speed of exit curve (mph)
 V'_a = average running speed on exit curve (mph)

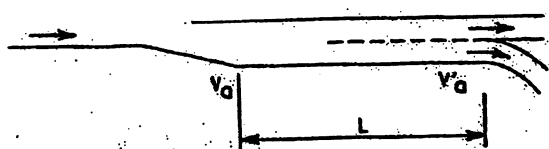

PARALLEL TYPE

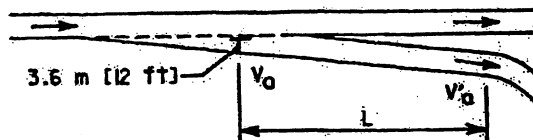

TAPER TYPE

Table 6.2 is replaced with the following Table:

TABLE 6.2
MINIMUM ACCELERATION LENGTHS FOR ENTRANCE TERMINALS WITH FLAT GRADES
OF 2 PERCENT OR LESS

Metric									
Acceleration length, L (m) for entrance curve design speed (km/h)									
Highway	Stop condition	20	30	40	50	60	70	80	
Design speed, V (km/h)	Speed reached, V_a (km/h)	and initial speed, V_a (km/h)							
	0	20	28	35	42	51	63	70	
50	37	60	50	30	-	-	-	-	-
60	45	95	80	65	45	-	-	-	-
70	53	150	130	110	90	65	-	-	-
80	60	200	180	165	145	115	65	-	-
90	67	260	245	225	205	175	125	35	-
100	74	345	325	305	285	255	205	110	40
110	81	430	410	390	370	340	290	200	125
120	88	545	530	515	490	460	410	325	245

Note: Uniform 50:1 to 70:1 tapers are recommended where lengths of acceleration lanes exceed 400 m.

US Customary									
Acceleration length, L (ft) for entrance curve design speed (mph)									
Highway	Stop condition	15	20	25	30	35	40	45	50
Design speed, V (mph)	Speed reached, V_a (mph)	and initial speed, V_a (mph)							
	0	14	18	22	26	30	36	40	44
30	23	180	140	-	-	-	-	-	-
35	27	280	220	160	-	-	-	-	-
40	31	360	300	270	210	120	-	-	-
45	35	560	490	440	380	280	160	-	-
50	39	720	660	610	550	450	350	130	-
55	43	960	900	810	780	670	550	320	150
60	47	1200	1140	1100	1020	910	800	550	420
65	50	1410	1350	1310	1220	1120	1000	770	600
70	53	1620	1560	1520	1420	1350	1230	1000	820
75	55	1790	1730	1630	1580	1510	1420	1160	1040

Note: Uniform 50:1 to 70:1 tapers are recommended where lengths of acceleration lanes exceed 1,300 ft.

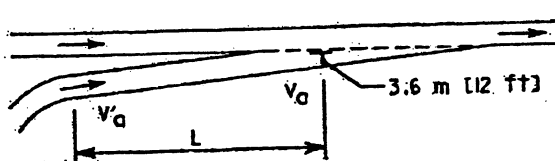

TAPER TYPE

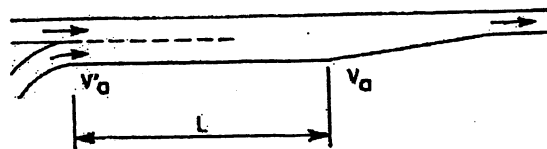

PARALLEL TYPE

Table 6.3 is replaced with the following Table:

TABLE 6.3
SPEED CHANGE LANE ADJUSTMENT FACTORS AS A FUNCTION OF GRADE

Metric		US Customary							
Design speed of highway (km/h)	Deceleration lanes Ratio of length on grade to length on level for design speed of turning curve (km/h) ^a	All speeds	3 to 4% upgrade		3 to 4% downgrade		All speeds		
			0.9	0.8	1.2	1.35			
All speeds	5 to 6% upgrade	0.8	5 to 6% upgrade		5 to 6% downgrade		1.35		
			0.8	0.8	1.2	1.35			
Design speed of highway (km/h)	Acceleration lanes Ratio of length on grade to length of level for design speed of turning curve (km/h) ^a	All speeds	Metric						
			40	50	60	70	80	All speeds	
60	3 to 4% upgrade	1.3	1.3	1.4	1.4	1.5	1.6	1.8	3 to 4% upgrade
			1.3	1.4	1.5	1.5	1.6	1.8	3 to 4% upgrade
70	3 to 4% upgrade	1.3 <td>1.3</td> <td>1.4</td> <td>1.5</td> <td>1.5</td> <td>1.6</td> <td>1.8</td> <td>3 to 4% upgrade</td>	1.3	1.4	1.5	1.5	1.6	1.8	3 to 4% upgrade
			1.3	1.4	1.5	1.5	1.6	1.8	3 to 4% upgrade
80	3 to 4% upgrade	1.3 <td>1.3</td> <td>1.4</td> <td>1.5</td> <td>1.5</td> <td>1.6</td> <td>1.8</td> <td>3 to 4% upgrade</td>	1.3	1.4	1.5	1.5	1.6	1.8	3 to 4% upgrade
			1.3	1.4	1.5	1.5	1.6	1.8	3 to 4% upgrade
90	3 to 4% upgrade	1.35 <td>1.35</td> <td>1.4</td> <td>1.5</td> <td>1.5</td> <td>1.6</td> <td>1.8</td> <td>3 to 4% upgrade</td>	1.35	1.4	1.5	1.5	1.6	1.8	3 to 4% upgrade
			1.35	1.4	1.5	1.5	1.6	1.8	3 to 4% upgrade
100	3 to 4% upgrade	1.4 <td>1.4</td> <td>1.5</td> <td>1.6</td> <td>1.7</td> <td>1.8</td> <td>1.8</td> <td>3 to 4% upgrade</td>	1.4	1.5	1.6	1.7	1.8	1.8	3 to 4% upgrade
			1.4	1.5	1.6	1.7	1.8	1.8	3 to 4% upgrade
110	3 to 4% upgrade	1.45 <td>1.45</td> <td>1.5</td> <td>1.6</td> <td>1.7</td> <td>1.8</td> <td>1.8</td> <td>3 to 4% upgrade</td>	1.45	1.5	1.6	1.7	1.8	1.8	3 to 4% upgrade
			1.45	1.5	1.6	1.7	1.8	1.8	3 to 4% upgrade
120	3 to 4% upgrade	1.5 <td>1.5</td> <td>1.6</td> <td>1.7</td> <td>1.7</td> <td>1.8</td> <td>1.8</td> <td>3 to 4% upgrade</td>	1.5	1.6	1.7	1.7	1.8	1.8	3 to 4% upgrade
			1.5	1.6	1.7	1.7	1.8	1.8	3 to 4% upgrade
60	5 to 6% upgrade	1.5 <td>1.5</td> <td>1.6</td> <td>1.7</td> <td>1.8</td> <td>2.2</td> <td>2.5</td> <td>5 to 6% upgrade</td>	1.5	1.6	1.7	1.8	2.2	2.5	5 to 6% upgrade
			1.5	1.6	1.7	1.8	2.2	2.5	5 to 6% upgrade
70	5 to 6% upgrade	1.5 <td>1.5</td> <td>1.6</td> <td>1.7</td> <td>1.8</td> <td>2.2</td> <td>2.5</td> <td>5 to 6% upgrade</td>	1.5	1.6	1.7	1.8	2.2	2.5	5 to 6% upgrade
			1.5	1.6	1.7	1.8	2.2	2.5	5 to 6% upgrade
80	5 to 6% upgrade	1.5 <td>1.5</td> <td>1.6</td> <td>1.7</td> <td>1.8</td> <td>2.2</td> <td>2.5</td> <td>5 to 6% upgrade</td>	1.5	1.6	1.7	1.8	2.2	2.5	5 to 6% upgrade
			1.5	1.6	1.7	1.8	2.2	2.5	5 to 6% upgrade
90	5 to 6% upgrade	1.6 <td>1.6</td> <td>1.7</td> <td>1.8</td> <td>1.9</td> <td>2.2</td> <td>2.5</td> <td>5 to 6% upgrade</td>	1.6	1.7	1.8	1.9	2.2	2.5	5 to 6% upgrade
			1.6	1.7	1.8	1.9	2.2	2.5	5 to 6% upgrade
100	5 to 6% upgrade	1.7 <td>1.7</td> <td>1.8</td> <td>1.9</td> <td>2.0</td> <td>2.2</td> <td>2.5</td> <td>5 to 6% upgrade</td>	1.7	1.8	1.9	2.0	2.2	2.5	5 to 6% upgrade
			1.7	1.8	1.9	2.0	2.2	2.5	5 to 6% upgrade
110	5 to 6% upgrade	1.85 <td>1.85</td> <td>1.9</td> <td>2.0</td> <td>2.1</td> <td>2.2</td> <td>2.5</td> <td>5 to 6% upgrade</td>	1.85	1.9	2.0	2.1	2.2	2.5	5 to 6% upgrade
			1.85	1.9	2.0	2.1	2.2	2.5	5 to 6% upgrade
120	5 to 6% upgrade	2.0 <td>2.0</td> <td>2.1</td> <td>2.2</td> <td>2.3</td> <td>2.4</td> <td>2.5</td> <td>5 to 6% upgrade</td>	2.0	2.1	2.2	2.3	2.4	2.5	5 to 6% upgrade
			2.0	2.1	2.2	2.3	2.4	2.5	5 to 6% upgrade

^a Ratio from this table multiplied by the length in Exhibit 10-70 or Exhibit 10-73 gives length of speed change lane on grade.

Figure 6.13 is replaced with the following Figure:

FIGURE 6.13
WEAVING SECTIONS

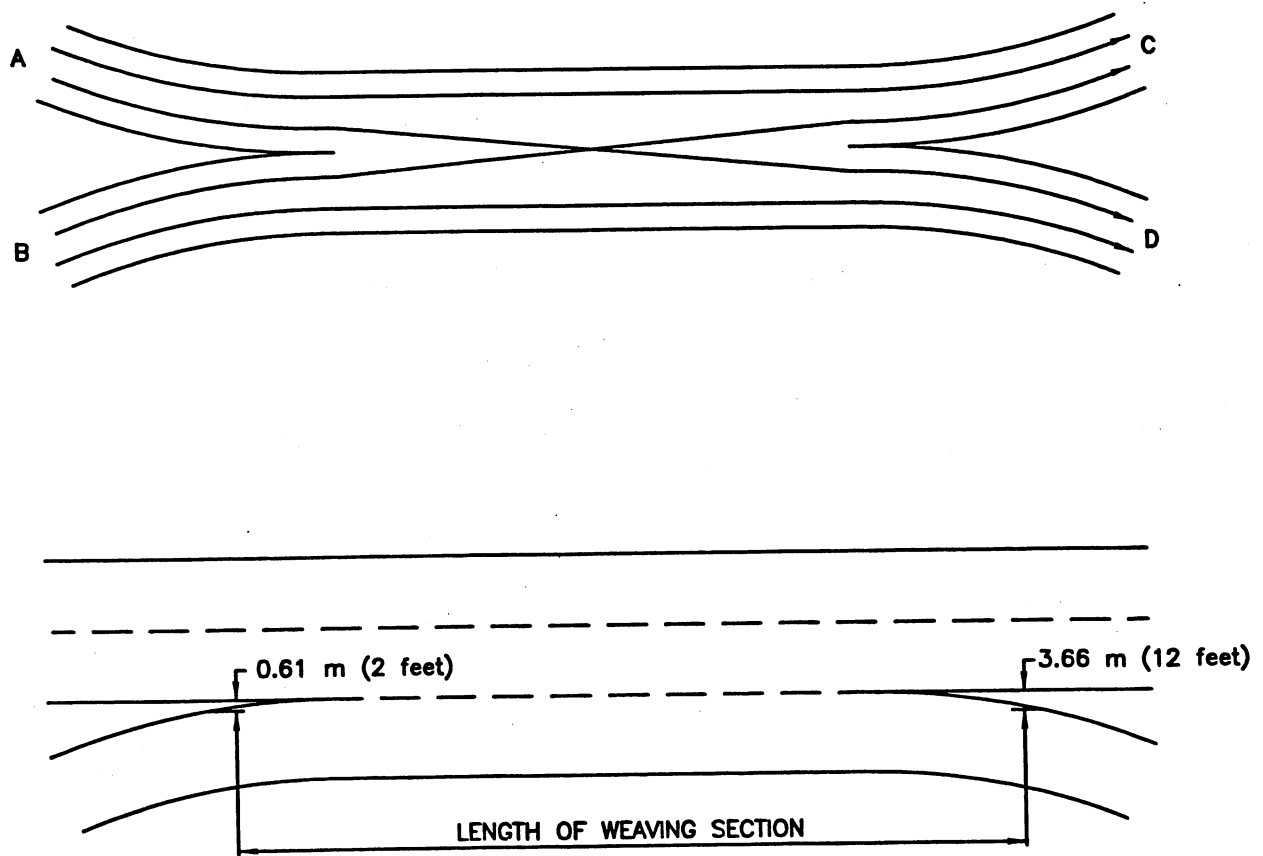

Figure 6-13. WEAVING SECTIONS

Page 6.43.0 Section 6.6.1.2 Cross Sections

Last line, replace with the following sentence:

Refer to Table 5.1 for recommended roadway section widths (travel lane widths and shoulder widths) for figures 6-18, 6-19, 6-21 through 6-29.

Page 7.01.0 Section 7.1.2 Vehicle Consideration

Replace the last paragraph with the following:

Vehicles turning paths yield minimum turning radii which are used in the design of intersection. Figures 7-1 to 7-8 illustrate the turning paths for the P, SU, BUS, A-BUS, WB-12, WB-15, WB-19 and WB-20 vehicles. Computer programs are available for this analysis. The vehicle dimensions in the figures are used to determine the turning radii design as discussed in Section 7.3.1. One of the semi-trailer combinations should typically be used as the design vehicle where truck traffic is anticipated. The SU vehicle should be the minimum size used. Turning paths for other design vehicles may be found in *A POLICY ON GEOMETRIC DESIGN OF HIGHWAYS AND STREETS, AASHTO, 2001*.

Delete the following pages:

Page 7.03.0, Page 7.05.0, Page 7.07.0, Page 7.09.0, Page 7.11.0, and Page 7.13.0

Figure 7.1 is replaced with the following Figure:

FIGURE 7.1
MINIMUM TURNING PATH FOR PASSENGER CAR (P) DESIGN VEHICLE

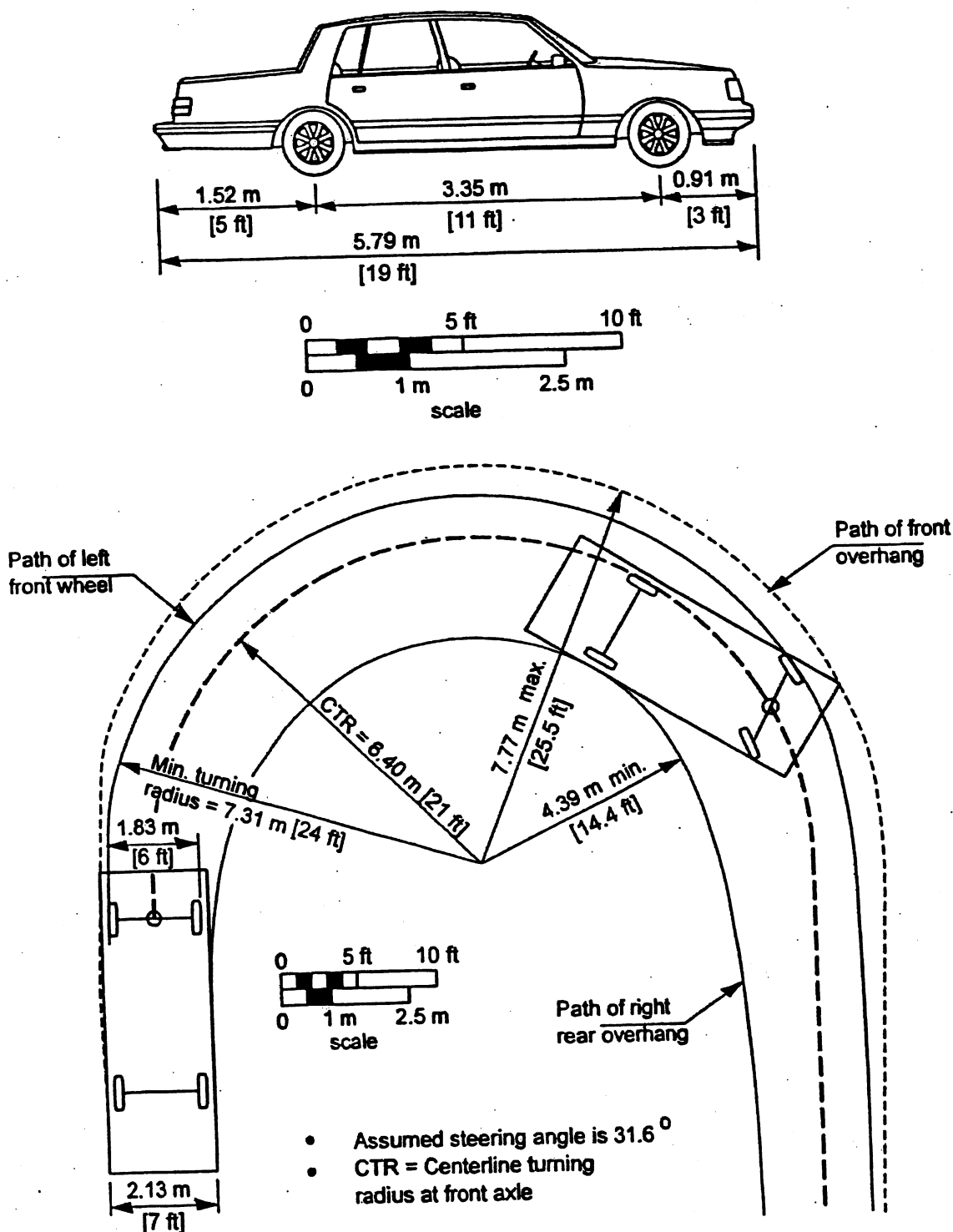

Figure 7.2 is replaced with the following Figure:

**FIGURE 7.2
MINIMUM TURNING PATH FOR SINGLE-UNIT (SU) TRUCK DESIGN VEHICLE**

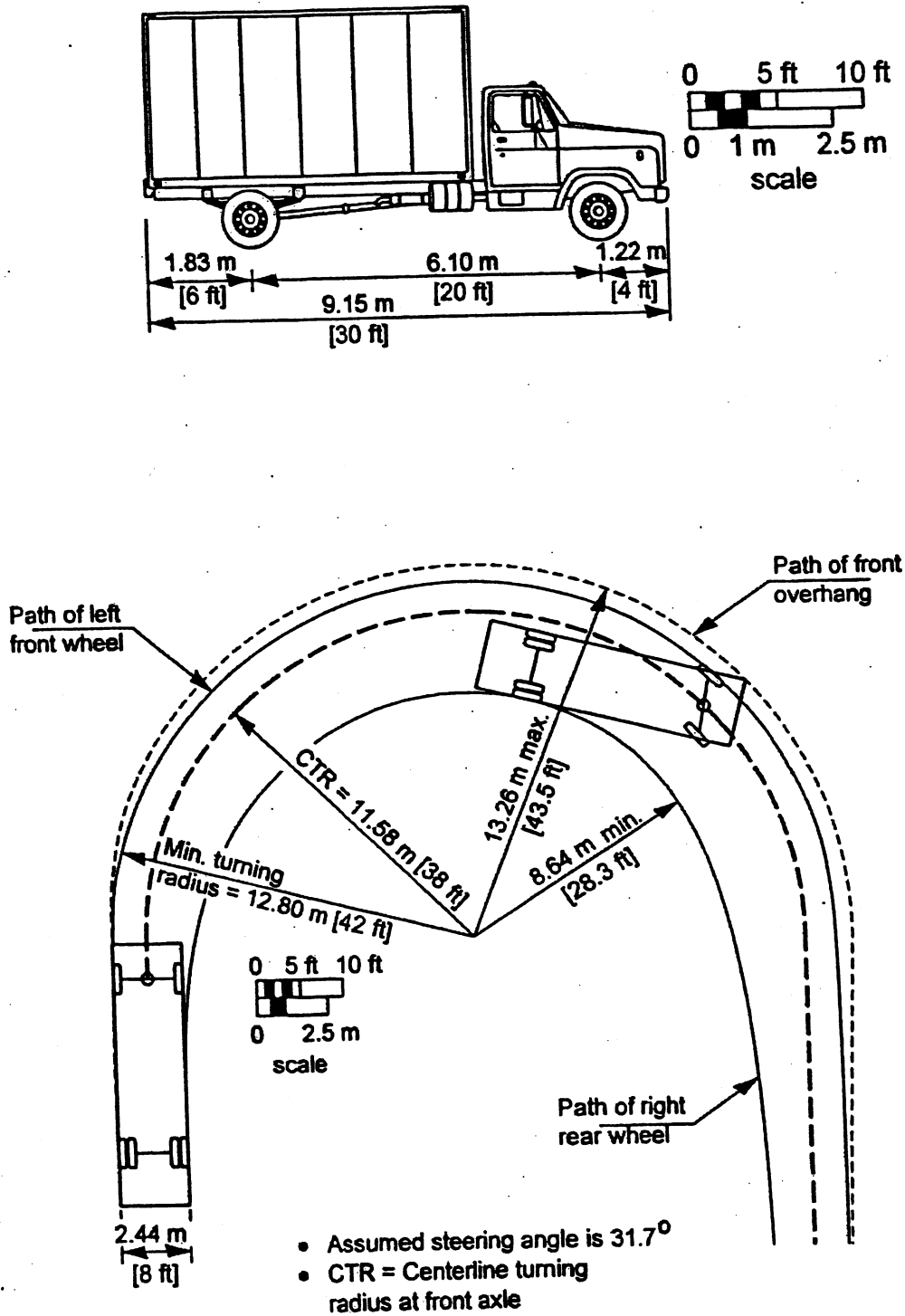
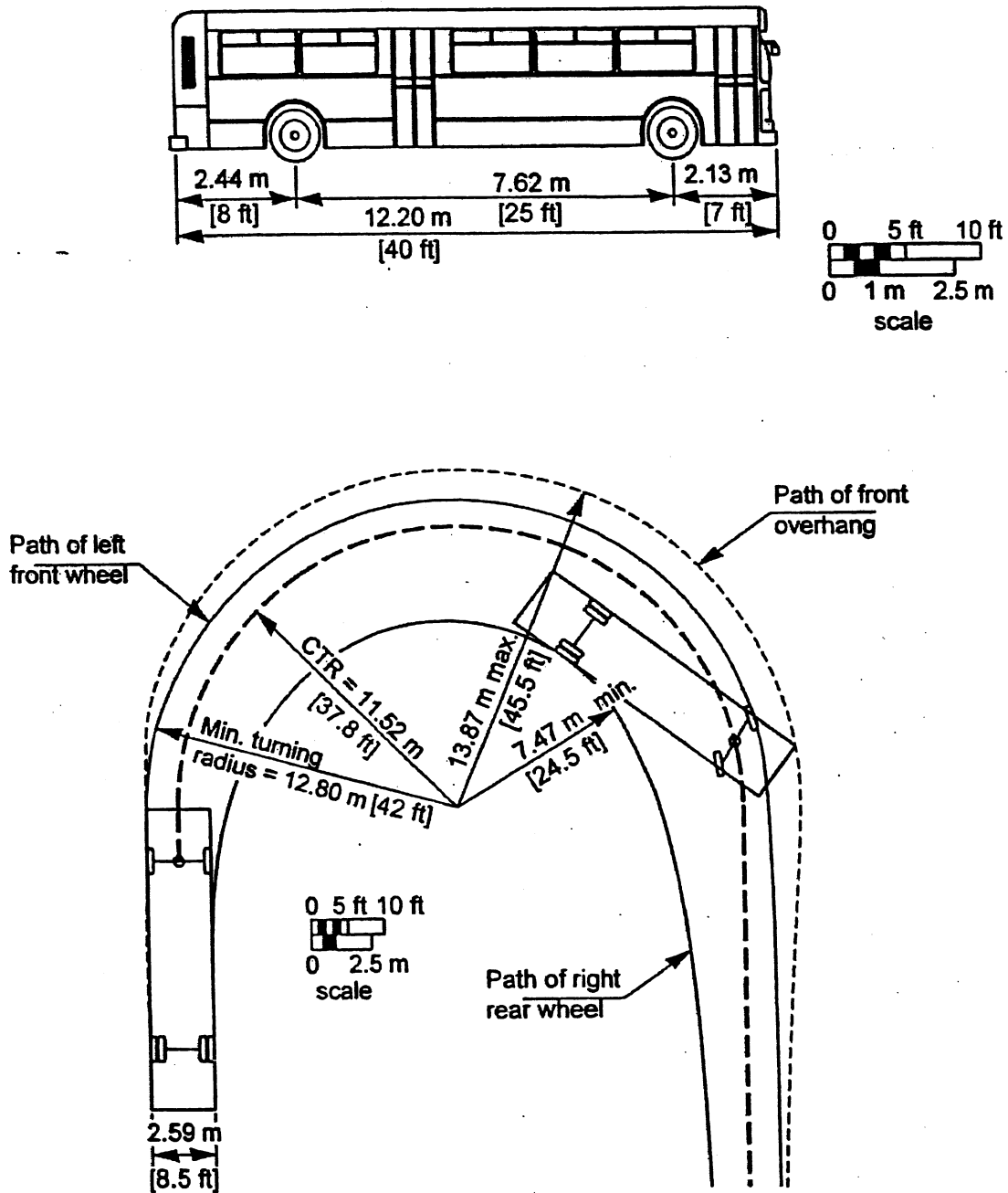

Figure 7.3 is replaced with the following Figure:

FIGURE 7.3
MINIMUM TURNING PATH FOR CITY TRANSIT BUS (CITY-BUS) DESIGN VEHICLE



- Assumed steering angle is 41°
- CTR = Centerline turning radius at front axle

Figure 7.4 is replaced with the following Figure:

FIGURE 7.4
MINIMUM TURNING PATH FOR ARTICULATED BUS (A-BUS) DESIGN VEHICLE

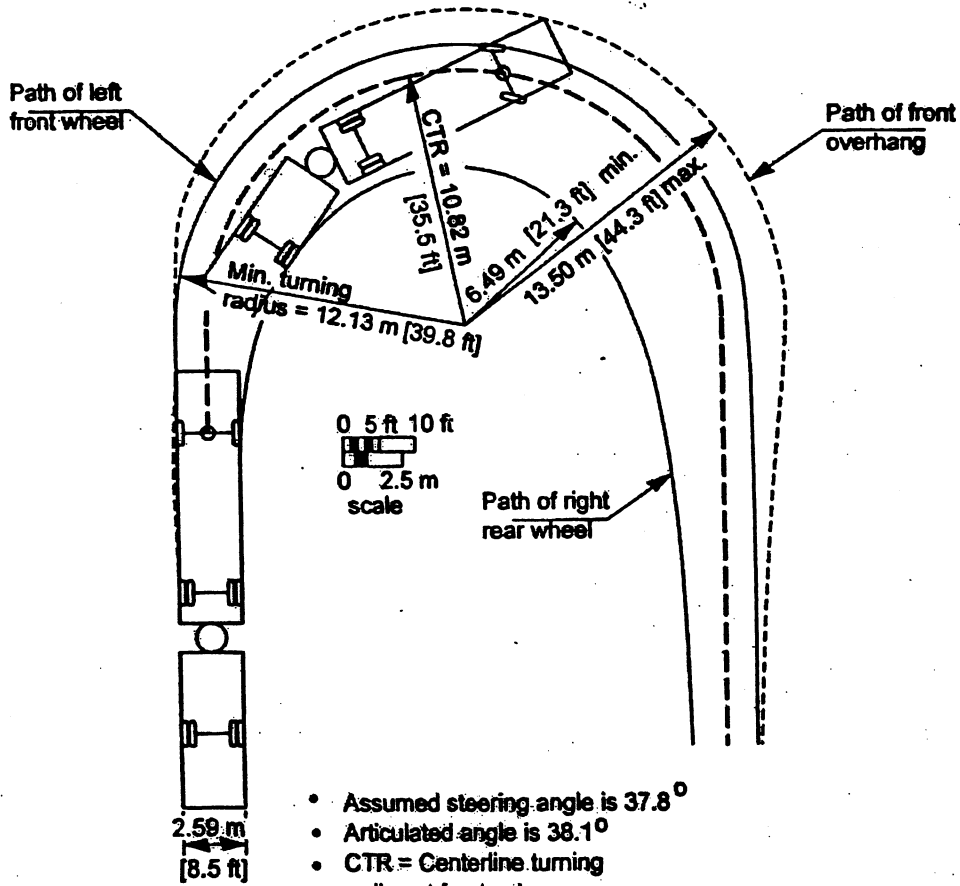
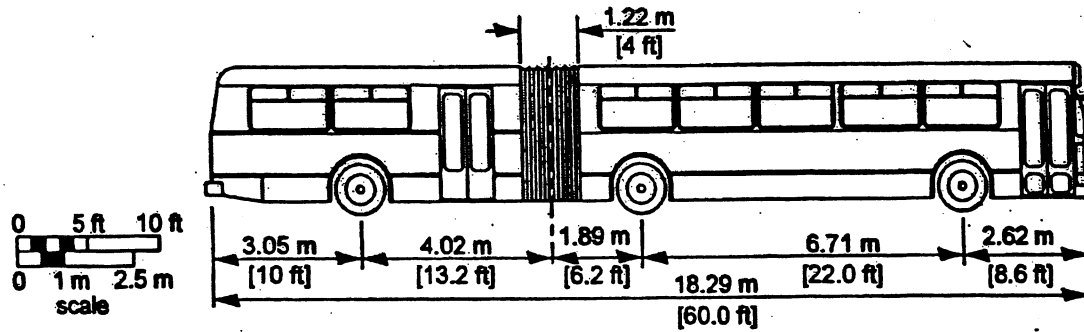

Figure 7.6 is replaced with the following Figure:

**FIGURE 7.6
MINIMUM TURNING PATH FOR INTERMEDIATE SEMITRAILER (WB-15 [WB-50])
DESIGN VEHICLE**

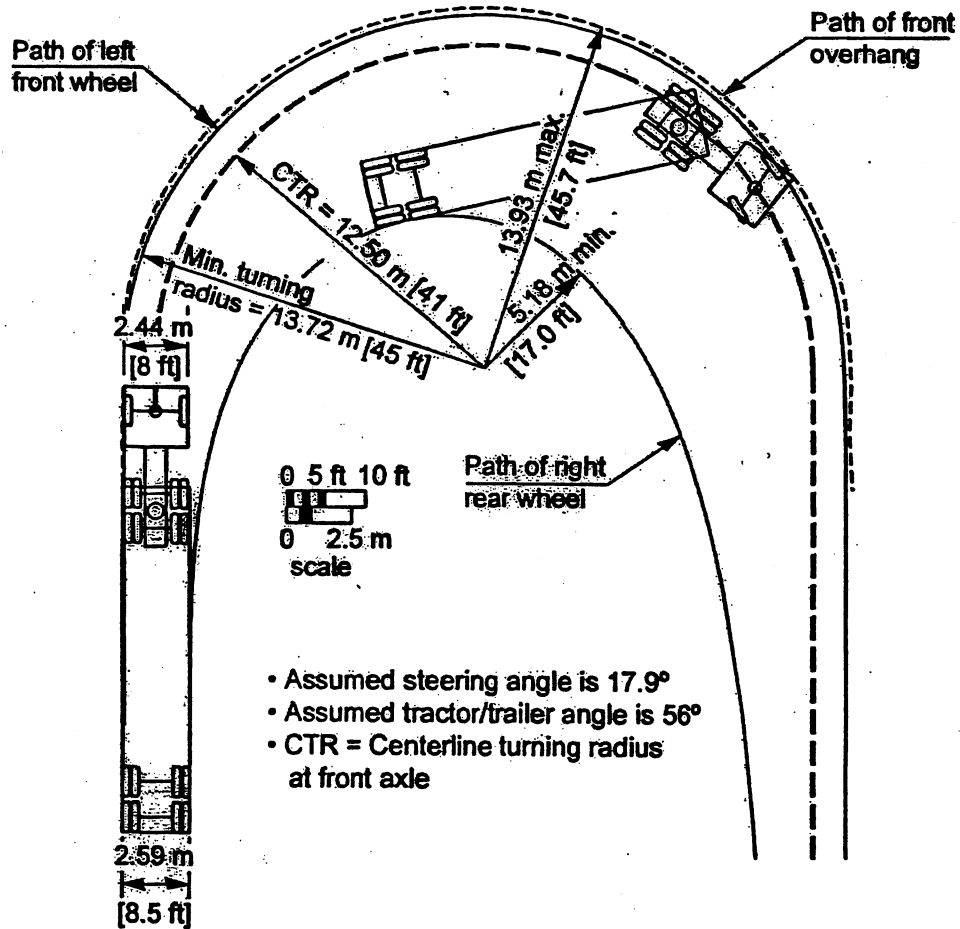
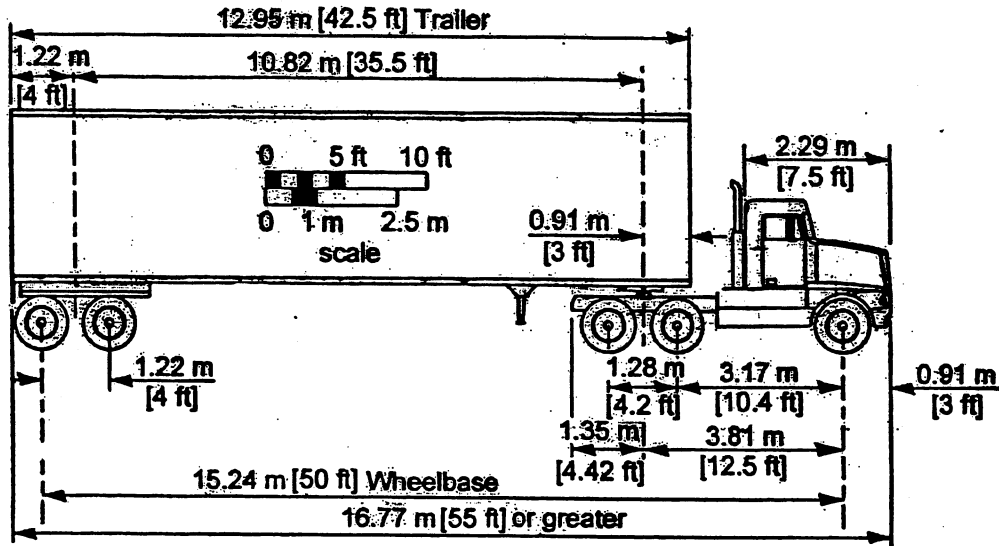
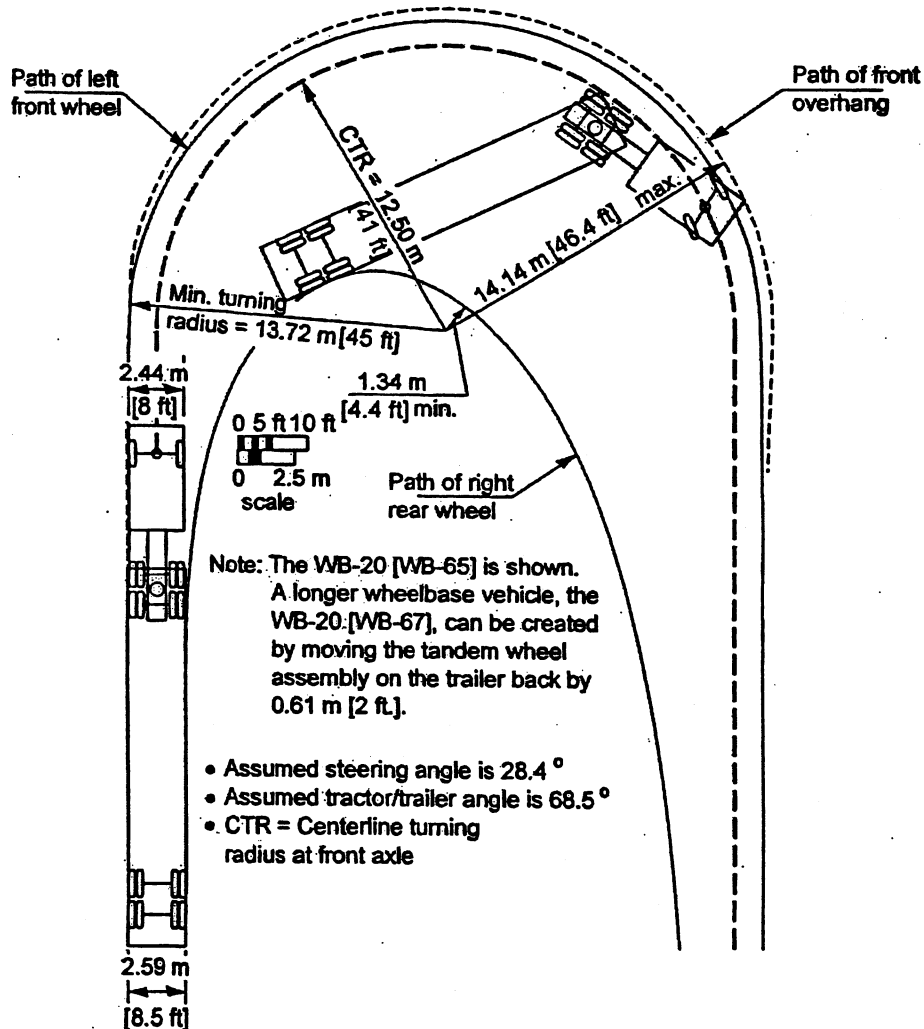
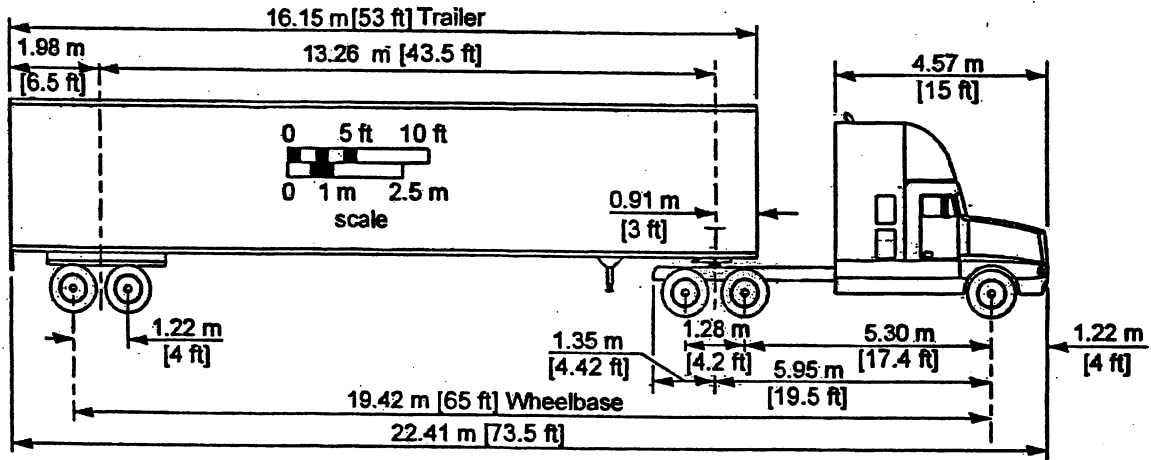

Figure 7.7 is replaced with the following Figure:

FIGURE 7.8
MINIMUM TURNING PATH FOR INTERSTATE SEMITRAILER (WB-20 [WB-65 AND WB-67])
DESIGN VEHICLE



Page 7.19.0 Section 7.1.6 Control

Last paragraph: replace Part IV of the MUTCD. With **Part 4 of the MUTCD**.

Page 7.20.0 Section 7.1.6 Control

Third paragraph: replace MUTCD. with **the MUTCD 2000**.

Replace the fourth paragraph with the following:

The investigation of the need for a traffic control signal shall include an analysis of the applicable factors contained in the following traffic signal warrants and other factors related to existing operation and safety at the study location:

Warrant 1, Eight-Hour Vehicular Volume.

Warrant 2, Four-Hour Vehicular Volume.

Warrant 3, Peak Hour.

Warrant 4, Pedestrian Volume.

Warrant 5, School Crossing

Warrant 6, Coordinated Signal System

Warrant 7, Crash Experience

Warrant 8, Roadway Network

Last paragraph before the last: replace Section II of the MUTCD. with **Section 2 of the MUTCD 2000**.

Page 7.21.0 Section 7.1.6 Control

Replace the first three paragraphs, including the bottom sentence on Page 7.20.0 with the following:

A number of techniques are available for evaluating the operation of signalized and unsignalized intersections, determining the appropriate signal-timing scheme and evaluating design alternatives. Among these techniques, the most important are:

- **Lane Movement based capacity analysis technique from the latest edition of the Highway Capacity Manual (HCM).**

- **Computer software applications based on the latest edition of the HCM, including: Highway Capacity Software (HCS), Trafficware – Synchro, and aaSIDRA (Signalized and unsignalized Intersection Design and Research Aid).**
- **Vehicle queue lengths are a required output for all intersection capacity analysis calculations. The calculation should measure the average and 95th-percentile maximum back of queue, and utilized an average vehicle spacing of 7.62 meters.**
- **For signal-optimization, vehicle progression or signal coordination techniques, the use of one of the following programs is encouraged:**
 - a. **Synchro**
 - b. **Transyt 7-F**
 - c. **Passer II**
- **For simulation of traffic signal systems on an arterial or network, the use of either of the following programs is suggested:**
 - a. **SimTraffic**
 - b. **TSIS (CORSIM)**

Page 7.23.0 Section 7.2 INTERSECTION SIGHT DISTANCE

Eliminate whole Section 7.2 and refer to:

AASHTO 2001, CHAPTER 9	
Alignment and Profile	Pages 584 through 586
INTERSECTION SIGHT DISTANCE	Pages 654 through 680
Effect of Skew	Page 681

Page 7.36.0 Section 7.3 INTERSECTION TURNS

Add the following first paragraph:

Refer to Table 5.1 for recommended roadway section widths.

Page 7.59.0 Section 7.3.3 Two-Way Left-Turn Lanes

Last paragraph: replace The preferred lane width is 4.5 meters with a minimum of 3.75 with **The preferred lane width is 4.57 meters with a minimum of 3.66**

Page 8.02.0 Section 8.1 DESIGN EXCEPTIONS

First paragraph: replace justified within Function Design Report. With **justified with a Function Design Report**.

Delete second paragraph

Delete Table 8.1

Page 8.03.0 Section 8.1 DESIGN EXCEPTIONS

Delete first two lines (top of page)

Page 8.05.0 Section 8.2 Low Speed/Low Volume Roads

Last paragraph: replace Low speed is defined as less than 70 km/h. with **Low speed is defined as less than or equal 70 km/h (45 km/h)**.

Page 8.07.0 Section 8.2.1 Design Criteria for Low Speed/Low Volume Roadways

Delete Table 8.2

Refer to Table 5.1 for Minimum Roadway Widths for Low Speed/Low Volume Roadways

Replace Section 9.1 with the following:

9.1 CRASH DATA AND APPLICATIONS

9.1.1 MHD Crash Data System

Historical crash data should be reviewed during the design of any reconstruction project. A minimum of the latest 3 years of crash data is required for calculation of crash rates, analysis of trends, and documentation of probable causes; including geometric shortfalls, safety hazards, and stopping sight distances if applicable. Discussion of potential remedial action should be included along with suggested mitigative design measures to address the identified hazards.

Crash rates should be calculated for intersections based on a Million Entering Vehicles (MEV) and for roadway segments based on a Hundred Million Vehicle kiloMeters of travel (HMVM) if adequate crash data is available. The equations for calculating these rates are as follows:

$$R_{Int.} = \frac{A * 1,000,000}{V * T} \qquad R_{seg.} = \frac{A * 100,000,000}{VMT}$$

Where:

- A = Average number of crashes at the study location, during a given time period (usually 1 year = 365 days)
- V = Intersection ADT (all approach legs)
- VMT = Segment ADT * Time Period * Length of Roadway Section
- T = Time, expressed in the number of days in the study period

Crash data is available for all State-maintained highways and local roadways from the MassHighway Traffic Operations & Safety section. The following crash reports can be obtained:

1. Annual City & Town Data Files - The Crash Data System (CDS) can provide a summary of all of the crashes, both vehicular and pedestrian, for any given city or town in the Commonwealth. All crash specific details are included in these reports.
2. Top 1000 High Crash Locations Report - A summary analysis of three-years of crash data to generate the top 1000 high crash locations in the State in terms of crash occurrence and severity. Data classified by rank and alphabetically by city and town.
3. Intersection Crash Rates - The average statewide crash rates for both signalized and unsignalized intersections are computed based on available data. District specific rates are also generated.

Future system enhancements will generate additional report and querying functions for the CDS. It is anticipated that the crash data system will be linked to a Geographic Information Systems (GIS) format to improve on the location data and statistical reporting.

Figure 9.2 is replaced with the following Figure:

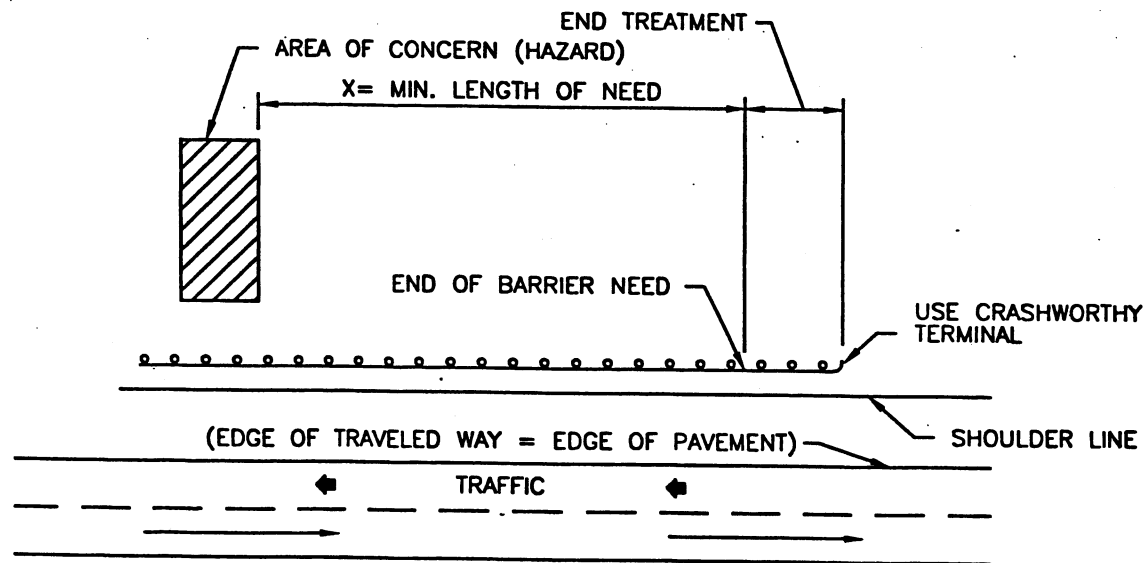

**SEE THE 2002 AASHTO ROADSIDE DESIGN GUIDE
FOR LENGTH-OF-NEED CALCULATIONS**

Note:
THE DISTANCE BEYOND THE HAZARD SHOULD BE DETERMINED BY A LENGTH-OF-NEED CALCULATION FOR OPPOSING TRAFFIC, IF APPLICABLE.

Figure 9-2. BARRIER LENGTH OF NEED