



Geotextile Sand Filter

Massachusetts
Design & Installation Manual



Innovative Onsite Products & Solutions Since 1970

March 2021
www.eljen.com

Table of Contents

SUBJECT	PAGE
GLOSSARY OF TERMS.....	3
GSF SYSTEM DESCRIPTION	5
1.0 SYSTEM PRECONDITIONS	6
2.0 DESIGN AND INSTALLATION	7
3.0 TRENCH INSTALLATION SIZING AND GUIDELINES.....	15
4.0 BED INSTALLATION SIZING AND GUIDELINES	18
5.0 MOUND INSTALLATION GUIDELINES.....	21
6.0 DOSING DISTRIBUTION GUIDANCE	23
7.0 PRESSURE DISTRIBUTION GUIDANCE.....	23
8.0 SYSTEM VENTILATION.....	25
GSF DRAWINGS AND TABLES	
DRAWINGS	
FIGURE 1: GSF SYSTEM OPERATION	5
FIGURE 2: TYPICAL A42 CROSS SECTION	7
FIGURE 3: TYPICAL B43 CROSS SECTION	7
FIGURE 4: VERTICAL SEPARATION DISTANCE.....	8
FIGURE 5: SERIAL DISTRIBUTION DROP-BOX DETAIL.....	9
FIGURE 6: PLAN VIEW –TRENCH SYSTEM EXAMPLE	16
FIGURE 7: SECTION VIEW – TRENCH SYSTEM EXAMPLE – LEVEL SITE	16
FIGURE 8: SECTION VIEW – TRENCH SYSTEM – SLOPING SITE	16
FIGURE 9: PLAN VIEW – BED SYSTEM EXAMPLE – LEVEL SITE	19
FIGURE 10: SECTION VIEW – BED SYSTEM EXAMPLE.....	19
FIGURE 11: SECTION VIEW – BED SYSTEM EXAMPLE – SLOPING SITE	19
FIGURE 12: CROSS SECTION – MOUND SYSTEM.....	21
FIGURE 13: CROSS SECTION – SLOPED MOUND SYSTEM	21
FIGURE 14: PRESSURE PIPE PLACEMENT	23
FIGURE 15: PRESSURE CLEAN OUT	24
FIGURE 16: CONTOURED TRENCH PRESSURE DISTRIBUTION	24
FIGURE 17: VENT LAYOUTS FOR GRAVITY AND LOW PRESSURE SYSTEMS.....	25
FIGURE 18: GSF WITH 4" VENT EXTENDED TO CONVENIENT LOCATION	25
TABLES	
TABLE 1: SPECIFIED SAND SIEVE REQUIREMENTS.....	4
TABLE 2: A42 TRENCH SIZING CHART.....	11
TABLE 3: B43 TRENCH SIZING CHART.....	12
TABLE 4: A42 BED SIZING CHART	13
TABLE 5: B43 BED SIZING CHART	14

Glossary of Terms

A42 Module	48" x 24" x 7" (L x W x H)
B43 Module	48" x 36" x 7" (L x W x H)
Cover Fabric	The geotextile cover fabric (provided by manufacturer) that is placed over the GSF modules.
Design Flow	The estimated peak flow that is used to size a GSF system is 110 gallons per day per Bedroom for residential systems or as specified in 310 CMR 15.203. Non-residential systems shall meet effluent quality standards for residential septic effluent or include additional pretreatment to meet these water quality requirements.
Distribution Box	A plastic or concrete box that receives effluent from a septic tank and splits the flow to pipes placed above the GSF modules. For equal distribution, the outlet pipe orifices are typically set at the same elevation to equalize the flow to each line.
GSF	The Eljen Geotextile Sand Filter Modules and the 6-inch sand layer at the base and 6 inches along the sides of the modules.
GSF Module	The individual module of a GSF system. The module is comprised of a cusped plastic core and geotextile fabric.
Serial Distribution	For designs commonly used on sloping sites where GSF module rows are laid on contour at varying elevations and where each successive module row receives septic tank effluent only after the preceding module row have become full to the bottom of the invert. This design supports unequal length of module rows.
Sequential Distribution	A method of effluent distribution for sloping sites using drop boxes where the effluent discharges first to the lowest outlet in the upper most box and then backs up to a slightly higher overflow outlet to the next down slope row of modules. Sequential loading maximizes utilization of a row of modules and allows downstream rows to rest for use only during peak flows or stress conditions. It can also be applied to a distribution box for a level bed system by fitting the outlet pipes with dial-a-flows. This method of distribution also supports inspection and management of the system to define the percent of the system in use, maximum use, and to monitor and adjust system stress.

Specified Sand

To ensure proper system operation, the system **MUST** be installed using ASTM C33 Sand.

ASTM C33 sand will have less than 10% passing the #100 Sieve and less than 5% passing the # 200 sieve. Ask your material supplier for a sieve analysis to verify that your material meets the required specifications.

TABLE 1: SPECIFIED SAND SIEVE REQUIREMENTS

ASTM C33 SAND SPECIFICATION		
Sieve Size	Sieve Square Opening Size	Specification Percent Passing (Wet Sieve)
3/8 inch	9.52 mm	100
No. 4	4.76 mm	95 - 100
No. 8	2.38 mm	80 - 100
No. 16	1.19 mm	50 - 85
No. 30	590 μ m	25 - 60
No. 50	297 μ m	10 - 30
No. 100	149 μ m	< 10
No. 200	75 μ m	< 5

GSF System Description

Primary Treatment Zone

- Perforated pipe is centered above the GSF module to distribute septic effluent over and into corrugations created by the cusped core of the geotextile module.
- Septic effluent is filtered through the Bio-Matt fabric. The module's unique design provides increased surface area for biological treatment that greatly exceeds the module's footprint.
- Open air channels within the module support aerobic bacterial growth on the modules geotextile fabric interface, surpassing the surface area required for traditional absorption systems.
- An anti-siltation geotextile fabric covers the top and sides of the GSF module and protects the Specified Sand and soil from clogging, while maintaining effluent storage within the module.

Secondary Treatment Zone

- Effluent drips into the Specified Sand layer and supports unsaturated flow into the native soil. This Specified Sand/soil interface maintains soil structure, thereby maximizing the available absorption interface in the native soil. The Specified Sand supports nitrification of the effluent, which reduces oxygen demand in the soil, thus minimizing soil clogging from anaerobic bacteria.
- The Specified Sand layer also protects the soil from compaction and helps maintain cracks and crevices in the soil. This preserves the soil's natural infiltration capacity, which is especially important in finer textured soils, where these large channels are critical for long-term performance.
- Native soil provides final filtration and allows for groundwater recharge.

FIGURE 1: GSF SYSTEM OPERATION

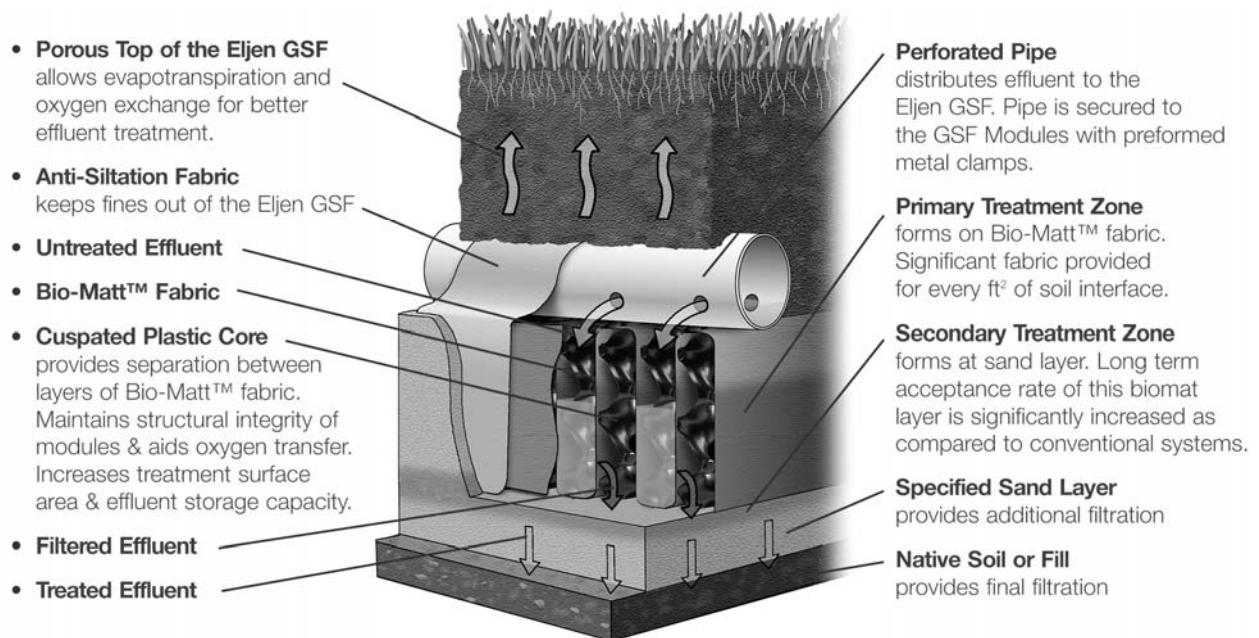

1.0 System Preconditions

1.1 REQUIREMENTS: GSF systems must meet the local rules and regulations except as outlined in this manual. The Massachusetts Title 5 regulations and the local regulations will be referred to as the *guidelines* in this manual. The sizing charts apply to residential systems only.

Please contact Eljen's Technical Resource Department at 1-800-444-1359 for design information on commercial systems.

1.2 WATER SOFTENER BACKWASH: At no time should water softener backwash be disposed of in the septic system. Water softener backwash should be discharged to a separate soil absorption field.

1.3 GARBAGE DISPOSALS: Eljen discourages the use of garbage disposals with septic systems. If a GSF system is to be designed and installed with garbage disposals the following measures must be taken to prevent solids from leaving the tank and entering the GSF system:

- Increase the septic tank capacity by a minimum of 50% or
- Installation of a second septic tank installed in series
- And a 50% larger leachfield

Eljen requires the use of septic tank outlet effluent filters on all systems especially on those systems that have single compartment tanks, even if up-sized, and when the dwelling has a garbage disposal installed.

1.4 ADDITIONAL FACTORS AFFECTING RESIDENTIAL SYSTEM SIZE: Homes with expected higher than normal water usage may consider increasing the septic tank volume as well as incorporating a multiple compartment septic tank. Consideration for disposal area may be up sized for expected higher than normal water use.

For example:

- Luxury homes, homes with a Jacuzzi style tubs, and other high use fixtures.
- Homes with known higher than normal occupancy.

1.5 SYSTEM PROHIBITED AREAS: All vehicular traffic is prohibited over the GSF system. GSF systems shall not be installed under paved or concreted areas. If the system is to be installed in livestock areas, the system must be fenced off around the perimeter to prevent compaction of the cover material and damage to the system.

1.6 OVERDIG: The use of a 5' overdig around the GSF system in a bed, trench or mound configuration is not required.

1.7 DEED NOTIFICATION: A deed notification is required when the GSF is used in a repair situation. Contact Eljen's Technical Department for a Deed Disclosure Notice at 800-444-1359 or info@eljen.com.

FIGURE 2: TYPICAL A42 CROSS SECTION

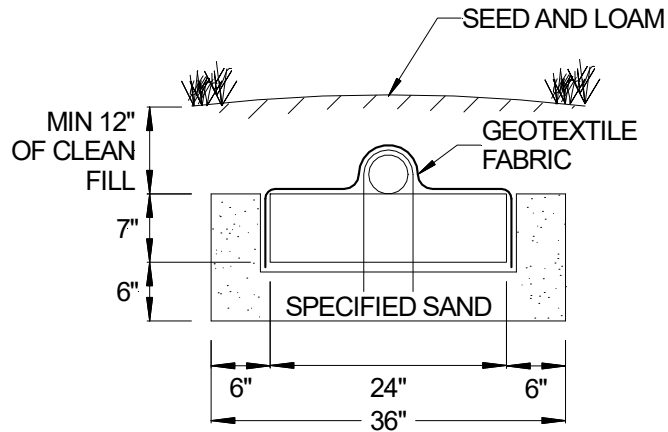

A42 MODULE (L x W x H) 48" x 24" x 7"

FIGURE 3: TYPICAL B43 CROSS SECTION

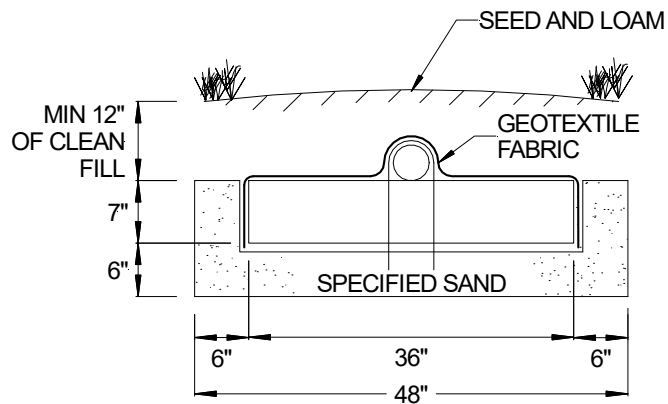

B43 MODULE (L x W x H) 48" x 36" x 7"

All systems are required to have a minimum of:

- 6 inches of Specified Sand is at the edges of the GSF module.
- 6 inches of Specified Sand is at the beginning and end of each GSF Row.
- 6 inches of Specified Sand is directly below the GSF module.
- Minimum 12 inches of cover above the module.

2.0 Design and Installation

2.2 SEPTIC TANKS: Dual compartment tanks are recommended for all systems. Eljen supports this practice as it helps to promote long system life by reducing TSS and BOD to the effluent disposal area. Effluent filters are also required.

2.2 SEPTIC TANK FILTERS: Septic tank effluent filters are **REQUIRED** on the outlet end of septic tank. Filter manufactures require that filters be cleaned from time to time. Ask your installer or designer for specific cleaning requirements based on the type or make of the filter installed. Eljen requires the septic tank to be pumped every three years or as needed which would be a good time to check and conduct filter maintenance.

2.3 VERTICAL SEPARATION TO LIMITING LAYER: The local approving authority may allow the following reductions without granting a waiver under 310 CMR 15.400 or obtaining MA DEP approval. Massachusetts remedial rules allow for a reduction in the depth of the naturally occurring pervious material or depth to groundwater to 2 feet. The Vertical Separation from bottom of the 6 inches of sand under the GSF units to the limiting layer shall not be less than 2 feet. It may be higher for percolation rates faster than 2 minutes per inch.

FIGURE 4: VERTICAL SEPARATION DISTANCE

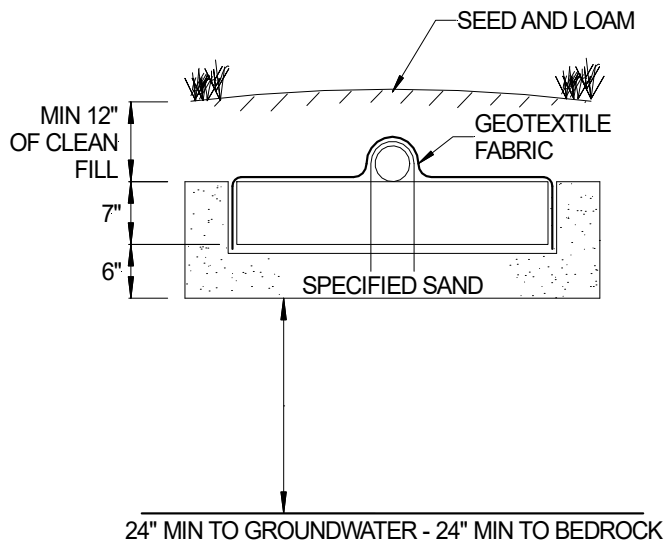

2.4 SPECIFIED SAND SPECIFICATION FOR GSF SYSTEMS: The sand immediately under, between rows and around the perimeter of the GSF system must meet **ASTM C33 SPECIFICATIONS, WITH LESS THAN 10% PASSING A #100 SIEVE AND LESS THAN 5% PASSING A #200 SIEVE**. Please place a prominent note to this effect on each design drawing. See Table 1 for more information on the sand and sieve specifications. Washed concrete sand easily meets the above specification and is a reliable choice. Suitability of bank run sand must be verified.

2.5 PLACING GSF MODULES: The "painted stripe" on the GSF modules indicates the top of the module and is not intended to indicate the location of the distribution pipe. With the painted stripe facing up, all rows of GSF modules are set level, end to end on the Specified Sand layer. Beds on level sites require a minimum spacing of 12" of Specified Sand between parallel module rows with 24" of separation required on sites with 15% to 20% slope. No mechanical connection is required between modules.

2.6 DISTRIBUTION: Gravity, pump to gravity or pressure distribution are acceptable when using the GSF System. Piping shall meet the requirements guidelines; however, Eljen strongly recommends the use of SDR 35 pipe and fittings as to prevent crushing during backfill.

All systems require a perforated 4" diameter pipe centered on top of the GSF modules unless the system is curving. The distribution pipe continues along the entire length of all modules in a trench or row. Holes are set at the 4 and 8 o'clock position and secured by the Eljen provided wire clamps.

When using pressure distribution, a pressure manifold is placed inside the 4-inch distribution pipe. Section 7.0 of this manual goes into details of how to construct the distribution network. All piping must meet state and local regulations.

2.0 Design and Installation

2.7 CONNECTIONS AND FITTINGS: Connections of lines to tanks and distribution boxes must be made using watertight mechanical seals. Use of any grouting material is not permitted.

2.8 DISTRIBUTION BOX CONNECTION: Plastic or concrete distribution boxes are acceptable. Provide D-Box(s) installed in accordance with 310 CMR 15.232. Distribution boxes must be installed level and on a compacted layer of sand or a base of gravel to prevent movement over time. Set gravity system distribution box outlet pipes 1/2" to 1/8" drop to per foot above the perforated pipe above the modules. A 2" minimum drop to the perforated pipe is required for pumped systems. Non-perforated pipes from the distribution box to the GSF modules must be placed on a compacted surface and secured with fill material that will prevent movement and settling. Dial-a-Flow fittings on outlet pipes are required for demand dosed systems.

2.9 PARALLEL DISTRIBUTION: Parallel distribution is the preferred method of dosing to a gravity or pump to gravity system. It encourages equal flows to each of the lines in the system. It is recommended for most trench systems.

2.10 SEQUENTIAL DISTRIBUTION: Sequential Distribution using a distribution box will fully utilize the uppermost section of the system prior to spilling effluent into a lower row of modules. This is for use on any site with greater than 0.5% slope when not using parallel distribution.

FIGURE 5: SEQUENTIAL DISTRIBUTION DROP-BOX DETAIL

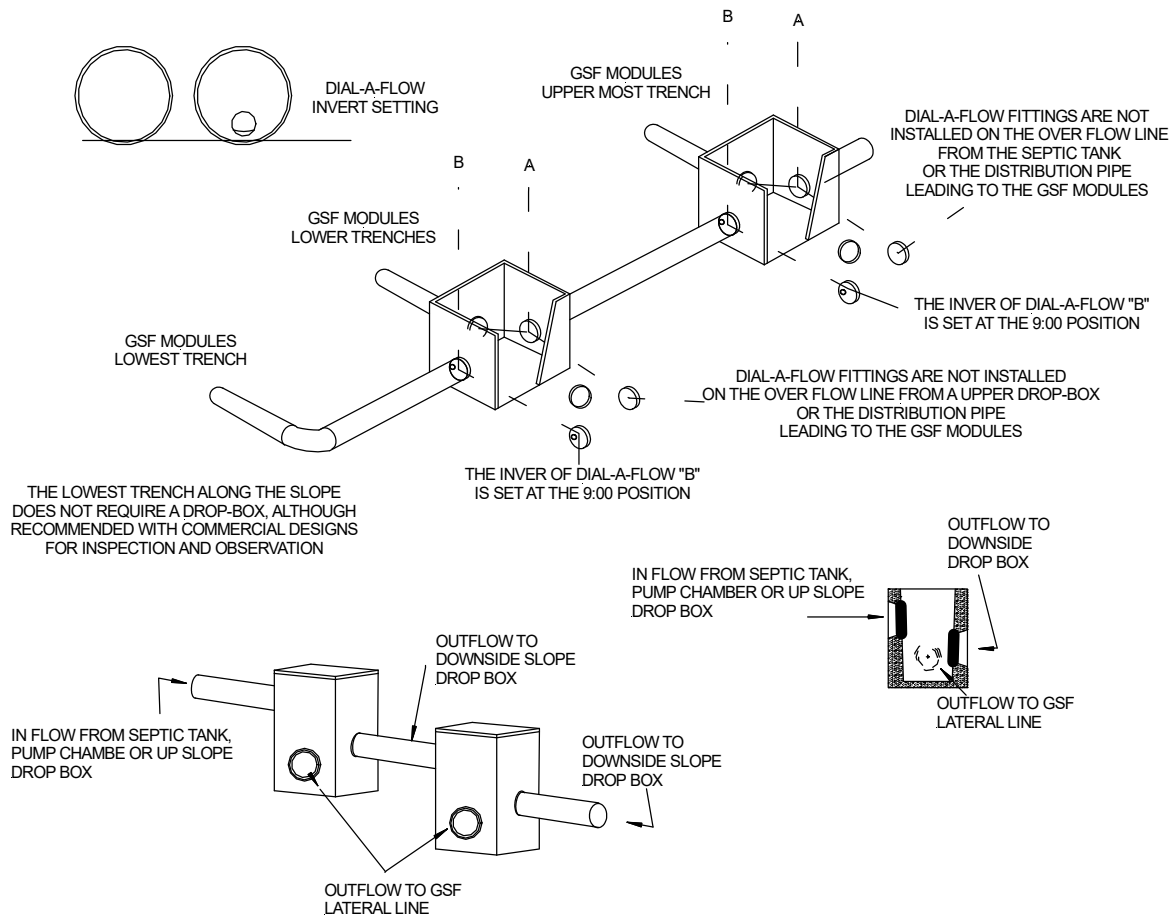

2.0 Design and Installation

2.11 COVER FABRIC: Geotextile cover fabric is provided by Eljen Corporation for all GSF systems. It is placed over the top and sides of the module rows to prevent long term siltation and failure. **Cover fabric substitution is not allowed.** Fabric should drape vertically over the pipe and must not block holes in the distribution pipe or be stretched from the top of the pipe to the outside edge of the modules. “Tenting” will cause undue stress on fabric and pipe.

2.12 SYSTEM VENTING: It is required to vent all systems that are over 18” below finished grade and systems beneath any surface condition that would not allow for surface air exchange with the system such as patios. Systems that exceed 50 feet in length require venting as well according to Title 5. See Section 8.0 for a more detailed explanation of venting GSF products.

2.13 BACKFILL & FINISH GRADING: Complete backfill with a minimum of 12 inches of clean, porous fill measured from the top of modules. Fill should conform to title 5 requirements. Title 5 requirements for Backfill are in 310 CMR 15.240 (9). Where natural backfill cannot be used, Title 5 fill is required. Backfill exceeding 18 inches requires venting at the far end of the trench or bed. Use well graded native soil fill that is clean, porous, and devoid of large rocks. Do not use wheeled equipment over the system. A light track machine may be used with caution, avoiding crushing, or shifting of pipe assembly. Divert surface runoff from the Effluent Disposal Area. Finish grade to prevent surface ponding. Place topsoil and seed system area to protect from erosion.

2.14 SYSTEM GEOMETRY: Design systems as long and narrow as practical along site contours to minimize ground water mounding especially in poorly drained low permeability soils. If possible, design level systems with equal number of modules per row.

For trench system using the A42, the edge to edge spacing is a minimum of 6 ft. For the B43 unit, the edge to edge spacing for trenches is 8 ft.

2.15 NUMBER OF GSF MODULES REQUIRED: Tables 2 – 5 indicate the minimum number of GSF modules required for various percolation rates and number of bedrooms. At a minimum, every system shall be sized at 5 B43 modules per bedroom or 6 A42 modules per bedroom. Units are scaled up for slower soils to improve distribution in the absorption area.

2.16 SIZING GSF SYSTEM FOR TRENCHES, BEDS & SAND MOUNDS: Eljen GSF products receive a 40% reduction to standard system sizing.

Eljen GSF modules can be used in conjunction with an ATU at a 50% sizing reduction. Eljen’s 40% reduction and an ATU’s 50% reduction **cannot** be combined. Individual counties may have different sizing based on local regulations.

Eljen GSF modules can also be used following nitrogen reduction systems.

2.0 Design and Installation

2.17 SIZING CHARTS:

TABLE 2: A42 TRENCH SIZING CHART

Trench Installations Effective Area: 34.4 ft ² per Module									
Table 2: Trench A42 Module	Percolation Rate	Application Rate GPD/ft ²	Minimum Trench Bottom Area Required (ft ²)			Minimum Number of Modules Required			Modules Per Each Additional Bedroom
			Bedrooms per House			Bedrooms per House			
			3	4	5	3	4	5	
Soil Type									
Class I	1 - 5	0.74	216	288	360	18	24	30	6
Class II	1 - 5	0.6	216	288	360	18	24	30	6
Class I	6	0.7	216	288	360	18	24	30	6
Class II	6	0.6	216	288	360	18	24	30	6
Class I	7	0.68	216	288	360	18	24	30	6
Class II	7	0.6	216	288	360	18	24	30	6
Class I	8	0.66	216	288	360	18	24	30	6
Class II	8	0.6	216	288	360	18	24	30	6
Class II	10	0.6	216	288	360	18	24	30	6
Class II	15	0.56	216	288	360	18	24	30	6
Class III	15	0.37	312	420	528	26	35	44	9
Class II	20	0.53	228	300	372	19	25	31	6
Class III	20	0.34	348	456	576	29	38	48	10
Class II	25	0.4	288	384	480	24	32	40	8
Class III	25	0.33	360	468	588	30	39	49	10
Class II	30	0.33	360	468	588	30	39	49	10
Class III	30	0.29	408	540	672	34	45	56	11
Class III	40	0.25	468	624	768	39	52	64	13
Class III & IV	50	0.2	576	768	960	48	64	80	16
Class III & IV	60	0.15	768	1032	1284	64	86	107	21
Remedial Use 60 - 90 MPI Systems									
Class III & IV	60	0.15	768	1032	1284	64	86	107	21
Pressure Dosed Systems									
Class III	40	0.29	408	540	672	34	45	56	11
Class III & IV	50	0.25	468	624	768	39	52	64	13
Class III & IV	60	0.2	576	768	960	48	64	80	16

1. The minimum number of A42s per bedroom is 6 modules per bedroom at 12 sf per module (actual bottom area).
2. The calculation for minimum trench bottom area is calculated by multiplying the conventional sizing by 60% (310 CMR 15.242) or calculating the actual footprint required for the minimum number of units per bedroom.
3. Wastewater flow is based on 110 gallons per bedroom in accordance with 310 CMR 15.203.
4. A minimum effective leaching area of 400 sf is required for new construction.
5. When recorded percolation rates are between those listed in 310 CMR 15.242, the next slower rate shall be used for design purposes.

2.0 Design and Installation

TABLE 3: B43 TRENCH SIZING CHART

Trench Installations Effective Area: 41.75 ft ² per Module									
Table 3: Trench B43 Module Soil Type	Percolation Rate	Application Rate GPD/ft ²	Minimum Trench Bottom Area Required (ft ²)			Minimum Number of Modules Required			Modules Per Each Additional Bedroom
			Bedrooms per House			Bedrooms per House			
			3	4	5	3	4	5	
Class I	1 - 5	0.74	240	320	400	15	20	25	5
Class II	1 - 5	0.6	240	320	400	15	20	25	5
Class I	6	0.7	240	320	400	15	20	25	5
Class II	6	0.6	240	320	400	15	20	25	5
Class I	7	0.68	240	320	400	15	20	25	5
Class II	7	0.6	240	320	400	15	20	25	5
Class I	8	0.66	240	320	400	15	20	25	5
Class II	8	0.6	240	320	400	15	20	25	5
Class II	10	0.6	240	320	400	15	20	25	5
Class II	15	0.56	240	320	400	15	20	25	5
Class III	15	0.37	352	464	576	22	29	36	7
Class II	20	0.53	240	320	400	15	20	25	5
Class III	20	0.34	384	512	624	24	32	39	8
Class II	25	0.4	320	432	528	20	27	33	7
Class III	25	0.33	384	512	640	24	32	40	8
Class II	30	0.33	384	512	640	24	32	40	8
Class III	30	0.29	448	592	736	28	37	46	9
Class III	40	0.25	512	688	848	32	43	53	11
Class III & IV	50	0.2	640	848	1056	40	53	66	13
Class III & IV	60	0.15	848	1136	1408	53	71	88	18
Remedial Use 60 - 90 MPI Systems									
Class III & IV	60	0.15	848	1136	1408	53	71	88	18
Pressure Dosed Systems									
Class III	40	0.29	448	592	736	28	37	46	9
Class III & IV	50	0.25	512	688	848	32	43	53	11
Class III & IV	60	0.2	640	848	1056	40	53	66	13

1. The minimum number of B43s per bedroom is 5 modules per bedroom at 16 sf per module (actual bottom area).
2. The calculation for minimum trench bottom area is calculated by multiplying the conventional sizing by 60% (310 CMR 15.242) or calculating the actual footprint required for the minimum number of units per bedroom.
3. Wastewater flow is based on 110 gallons per bedroom in accordance with 310 CMR 15.203.
4. A minimum effective leaching area of 400 sf is required for new construction.
5. When recorded percolation rates are between those listed in 310 CMR 15.242, the next slower rate shall be used for design purposes.

2.0 Design and Installation

TABLE 4: A42 BED SIZING CHART

Bed Installations Effective Area: 20.04 ft ² per Module									
Table 4: Bed A42 Module Soil Type	Percolation Rate	Application Rate GPD/ft ²	Minimum Basal Area Required (ft ²)			Minimum Number of Modules Required			Modules Per Each Additional Bedroom
			Bedrooms per House			Bedrooms per House			
			3	4	5	3	4	5	
Class I	1 - 5	0.74	268	357	446	18	24	30	6
Class II	1 - 5	0.6	330	440	550	18	24	30	6
Class I	6	0.7	283	378	472	18	24	30	6
Class II	6	0.6	330	440	550	18	24	30	6
Class I	7	0.68	292	389	486	18	24	30	6
Class II	7	0.6	330	440	550	18	24	30	6
Class I	8	0.66	300	400	500	18	24	30	6
Class II	8	0.6	330	440	550	18	24	30	6
Class II	10	0.6	330	440	550	21	28	35	7
Class II	15	0.56	354	472	590	21	28	35	7
Class III	15	0.37	536	714	892	24	32	40	8
Class II	20	0.53	374	499	623	24	32	40	8
Class III	20	0.34	583	777	971	24	32	40	8
Class II	25	0.4	495	660	825	27	36	45	9
Class III	25	0.33	600	800	1000	27	36	45	9
Class II	30	0.33	600	800	1000	27	36	45	9
Class III	30	0.29	683	911	1138	30	40	50	10
Class III	40	0.25	792	1056	1320	33	44	55	11
Class III & IV	50	0.2	990	1320	1650	39	52	65	13
Class III & IV	60	0.15	1320	1760	2200	39	52	65	13
Remedial Use 60 - 90 MPI Systems									
Class III & IV	60	0.15	1320	1760	2200	39	52	65	13
Pressure Dosed Systems									
Class III	40	0.29	683	911	1138	30	40	50	10
Class III & IV	50	0.25	792	1056	1320	39	52	65	13
Class III & IV	60	0.2	990	1320	1650	39	52	65	13

1. The minimum number of A42s per bedroom is 6 modules per bedroom.
2. The calculation for minimum basal area is calculated by multiplying the conventional sizing by 60% (310 CMR 15.242) or calculating the actual footprint required for the minimum number of units per bedroom.
3. Wastewater flow is based on 110 gallons per bedroom in accordance with 310 CMR 15.203.
4. A minimum effective leaching area of 400 sf is required for new construction.
5. When recorded percolation rates are between those listed in 310 CMR 15.242, the next slower rate shall be used for design purposes.

2.0 Design and Installation

TABLE 5: B43 BED SIZING CHART

Bed Installations Effective Area: 26.72 ft ² per Module									
Table 5: Bed B43 Module Soil Type	Percolation Rate	Application Rate GPD/ft ²	Minimum Basal Area Required (ft ²)			Minimum Number of Modules Required			Modules Per Each Additional Bedroom
			Bedrooms per House			Bedrooms per House			
			3	4	5	3	4	5	
Class I	1 - 5	0.74	272	357	446	15	20	25	5
Class II	1 - 5	0.6	330	440	550	15	20	25	5
Class I	6	0.7	283	378	472	15	20	25	5
Class II	6	0.6	330	440	550	15	20	25	5
Class I	7	0.68	292	389	486	15	20	25	5
Class II	7	0.6	330	440	550	15	20	25	5
Class I	8	0.66	300	400	500	15	20	25	5
Class II	8	0.6	330	440	550	15	20	25	5
Class II	10	0.6	330	440	550	18	24	30	6
Class II	15	0.56	354	472	590	18	24	30	6
Class III	15	0.37	536	714	892	21	28	35	7
Class II	20	0.53	374	499	623	21	28	35	7
Class III	20	0.34	583	777	971	21	28	35	7
Class II	25	0.4	495	660	825	24	32	40	8
Class III	25	0.33	600	800	1000	24	32	40	8
Class II	30	0.33	600	800	1000	24	32	40	8
Class III	30	0.29	683	911	1138	27	36	45	9
Class III	40	0.25	792	1056	1320	30	40	50	10
Class III & IV	50	0.2	990	1320	1650	33	44	55	11
Class III & IV	60	0.15	1320	1760	2200	33	44	55	11
Remedial Use 60 - 90 MPI Systems									
Class III & IV	60	0.15	2200	2934	3667	33	44	55	11
Pressure Dosed Systems									
Class III	40	0.29	1138	1518	1897	30	40	50	10
Class III & IV	50	0.25	1320	1760	2200	33	44	55	11
Class III & IV	60	0.2	1650	2200	2750	33	44	55	11

1. The minimum number of B43s per bedroom is 5 modules per bedroom.
2. The calculation for minimum basal area is calculated by multiplying the conventional sizing by 60% (310 CMR 15.242) or calculating the actual footprint required for the minimum number of units per bedroom.
3. Wastewater flow is based on 110 gallons per bedroom in accordance with 310 CMR 15.203.
4. A minimum effective leaching area of 400 sf is required for new construction.
5. When recorded percolation rates are between those listed in 310 CMR 15.242, the next slower rate shall be used for design purposes.

3.0 Trench Installation Sizing and Guidelines

Trench Example:

House size: 4 Bedrooms
 Soil Permeability & Class: 30 min/in, Class III Soil
 Absorption Field Type: Trench
 Unit Used: A42

Calculate Minimum Number of Units and Bottom Area Required

Lookup the information required from Table 3:

Table 2: Trench A42 Module Soil Type	Percolation Rate	Application Rate GPD/ft ²	Minimum Trench Bottom Area Required (ft ²)			Minimum Number of Modules Required		
			Bedrooms per House			Bedrooms per House		
			3	4	5	3	4	5
Class III	30	0.29	408	540	672	34	45	56

Minimum Units required 45 A42 Modules

Minimum Trench Bottom required 540 ft²

Calculate Minimum Trench Length

45 Units x 4 + 1 ft 181 linear feet

Trench Width

	Trench Width (ft)
A42	3
B43	4

Final Dimension Layout

(Note: System layout and number of rows will vary based on site constraints)

Min. Product Length	180 ft.
<i>(note: 6 inches of sand required at each end of trench making the minimum trench length 181 ft.)</i>	
Trench Width	3 ft.
Minimum Number of Units	45 A42 Modules
2 Trench Rows	22.5 Modules, round up to 23 Modules per row, 93 ft. per row.
3 Trench Rows	15 A42 per row, 61 ft. per row.
Min. System Area	540 ft ²

3.0 Trench Installation Sizing and Guidelines

FIGURE 6: PLAN VIEW – TRENCH SYSTEM EXAMPLE

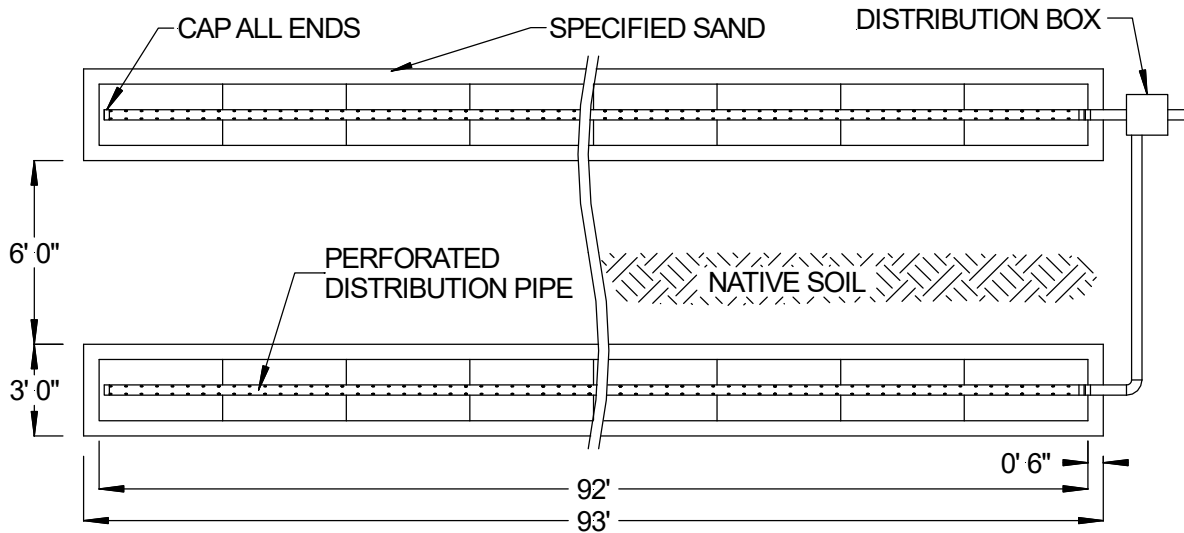

(*2 Rows of 9 A42's shown in Figure 6)

FIGURE 7: SECTION VIEW – TRENCH SYSTEM EXAMPLE – LEVEL SITE

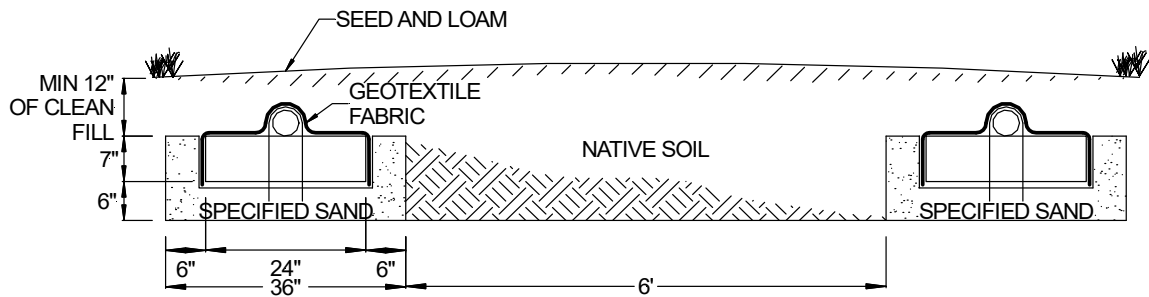
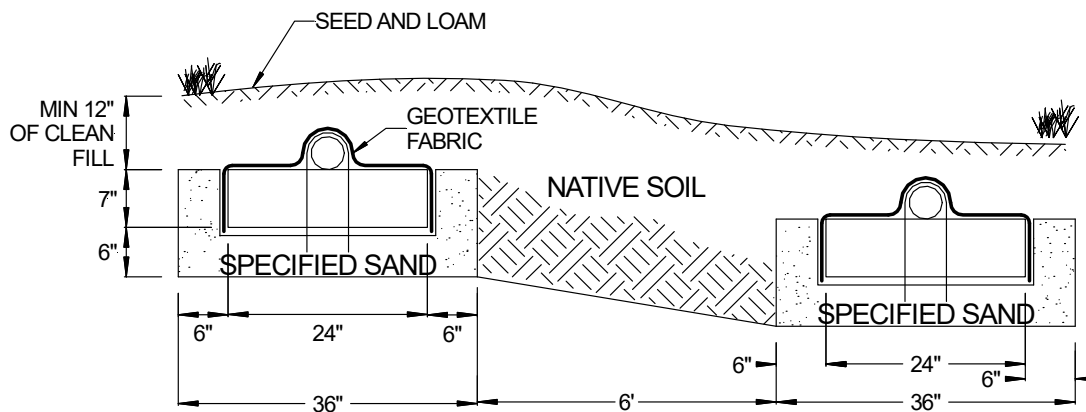

FIGURE 8: SECTION VIEW – TRENCH SYSTEM – SLOPING SITE



3.0 Trench Installation Sizing and Guidelines

1. Ensure all components leading to the GSF system are installed properly. Septic tank effluent filters are required with the GSF system.
2. Determine the number of GSF Modules required using the trench sizing example.
3. Prepare the site. Do not install a system on saturated ground or wet soils that are smeared during excavation. Keep machinery off infiltrative areas.
4. Plan all drainage requirements above (up-slope) of the system. Set soil grades to ensure that storm water drainage and ground water is diverted away from the absorption area once the system is complete.
5. Excavate the trench; prepare the receiving layer to maximize the interface between the native soil and specified sand.
6. Minimize walking in the trench prior to placement of the specified sand to avoid soil compaction.
7. Place specified sand in a 6" lift and stabilize by foot, a handheld tamping tool or a portable vibrating compactor. The minimum stabilized height below the GSF module must be level at 6".
8. Place GSF modules with **PAINTED STRIPE FACING UP**, end to end on top of the specified sand along their 4-foot length.
9. A standard 4-inch perforated pipe, SDR 35 or equivalent, is centered along the modules 4-foot length. Orifices are set at the 4 & 8 o'clock position.
10. All 4-inch pipes are secured with manufacturers supplied wire clamps, one per module.
11. (Pressure Distribution Systems) Insert a pressure pipe (size per design and code) into the standard 4-inch perforated pipe. The pressure pipe orifices are set at the 12 o'clock position as shown in Figure 14. Each pressure lateral will have a drain hole at the 6 o'clock position. Each pressure lateral shall include sweeping cleanouts at the terminal ends and be accessible from grade.
12. **Cover fabric substitution is not allowed.** The installer should lay the Eljen provided geotextile cover fabric lengthwise down the trench, with the fabric fitted to the perforated pipe on top of the GSF modules. Fabric should be neither too loose, nor too tight. The correct tension of the cover fabric is set by:
 - a. Spreading the cover fabric over the top of the module and down both sides of the module with the cover fabric tented over the top of the perforated distribution pipe.
 - b. Place shovelfuls of Specified Sand directly over the pipe area allowing the cover fabric to form a mostly vertical orientation along the sides of the pipe. Repeat this step moving down the pipe.
13. Place the sand extensions along both sides of the modules edge. A minimum of 6 inches of Specified Sand is placed at the beginning and end of each trench.
14. Complete backfill with a minimum of 12 inches of clean, porous fill measured from the top of the module. Backfill exceeding 18 inches requires venting at the far end of the trench. Use well graded native soil fill that is clean, porous, and devoid of large rocks. Do not use wheeled equipment over the system. A light track machine may be used with caution, avoiding crushing, or shifting of pipe assembly.
15. Divert surface runoff from the system. Finish grade to prevent surface ponding. Topsoil and seed system area to protect from erosion.

4.0 Bed Installation Sizing and Guidelines

Bed Example:

House size: 4 Bedrooms
 Soil Permeability & Class: 30 min/in, Class III Soil
 Absorption Field Type: Bed
 Unit Used: B43

Calculate Minimum Number of Units and Basal Area Required

Lookup the information required from Table 5:

Table 5: Bed B43 Module Soil Type	Percolation Rate	Application Rate GPD/ft ²	Minimum Basal Area Required (ft ²)			Minimum Number of Modules Required			Modules Per Each Additional Bedroom
			Bedrooms per House			Bedrooms per House			
			3	4	5	3	4	5	
Class III	30	0.29	683	911	1138	27	36	45	9

Minimum Units required **36 = 32 B43 Modules**

Minimum Basal Area required **911 ft²**

Calculate Minimum Bed Length

Maintain a minimum of 2 rows in a bed system. (4 Rows for this example)
 36 Units ÷ 4 Rows = 9 Mods/Row

Calculate Minimum Row Length

9 Units x 4 ft./unit + 1 ft = 37 ft per Row

Bed Width (Level Installation)

Bed Width = Basal Area Required ÷ Row Length
 911 ft² ÷ 37 ft = 24.6, round to 25 ft.

Determine Lateral Spacing

Lateral to Lateral Spacing = Bed Width ÷ Number of Rows
 4 Rows
 25 ft ÷ 4 rows = 6.25 ft

Lateral to Edge Spacing = Lateral to Lateral Spacing ÷ 2
 6.25 ft ÷ 2 = 3.125 ft

Final Dimension Layout

(Note: System layout and number of rows will vary based on site constraints)

Bed Length	37 ft.
Bed Width	25 ft.
Minimum Number of Units	36 Units
Units per Row	9 units per row
Lateral to Lateral Spacing	6.25 ft.
Lateral to Edge Spacing	3.125 ft.
System Area	925 ft ²

4.0 Bed Installation Sizing and Guidelines

FIGURE 9: PLAN VIEW – BED SYSTEM EXAMPLE – LEVEL SITE

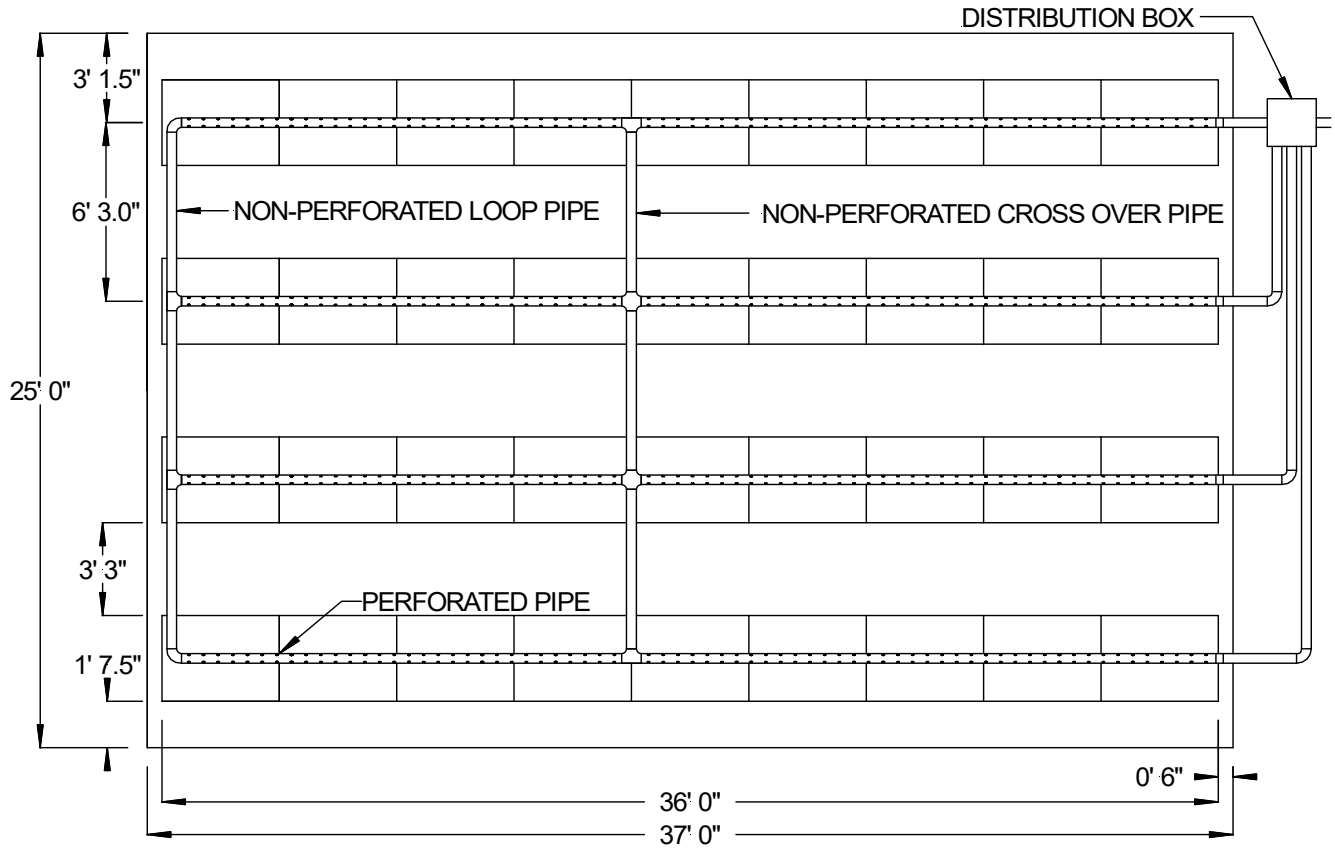

FIGURE 10: SECTION VIEW – BED SYSTEM EXAMPLE

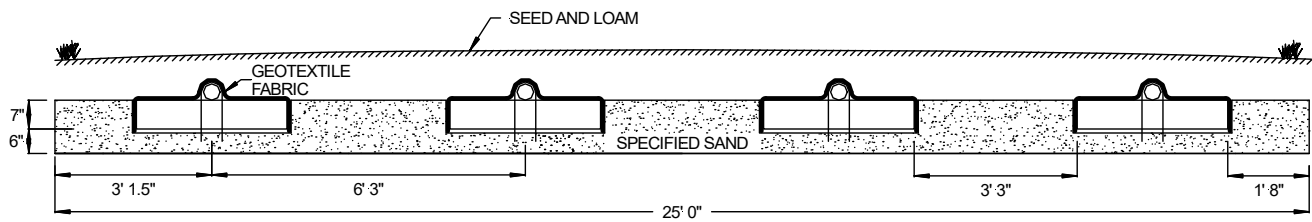
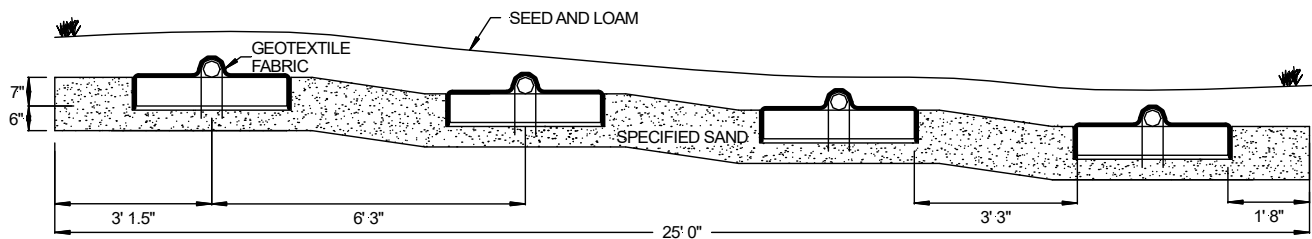

FIGURE 11: SECTION VIEW – BED SYSTEM EXAMPLE – SLOPING SITE



4.0 Bed Installation Sizing and Guidelines

1. Ensure all components leading to the GSF system are installed properly. Septic tank effluent filters are required with the GSF system.
2. Determine the number of GSF Modules required using the bed sizing example.
3. Prepare the site. Do not install a system on saturated ground or wet soils that are smeared during excavation. Keep machinery off infiltrative areas.
4. Plan all drainage requirements above (up-slope) of the system. Set soil grades to ensure that storm water drainage and ground water is diverted away from the absorption area once the system is complete.
5. Excavate the bed absorption area; prepare the receiving layer to maximize the interface between the native soil and specified sand.
6. Minimize walking in the absorption area prior to placement of the specified sand to avoid soil compaction.
7. Place specified sand in 6" lifts, stabilize by foot, a handheld tamping tool or a portable vibrating compactor. The minimum stabilized height below the GSF module must be level at 6".
8. Place GSF modules with **PAINTED STRIPE FACING UP**, end to end on top of the specified sand along their 4-foot length.
9. A standard 4-inch perforated pipe, SDR 35 or equivalent, is centered along the modules 4-foot length. Orifices are set at the 4 & 8 o'clock position.
10. All 4-inch pipes are secured with manufacturers supplied wire clamps, one per module.
11. (Pressure Distribution Systems) Insert a pressure pipe (size per design and code) into the standard 4-inch perforated pipe. The pressure pipe orifices are set at the 12 o'clock position as shown in Figure 14. Each pressure lateral will have a drain hole at the 6 o'clock position. Each pressure lateral shall include sweeping cleanouts at the terminal ends and be accessible from grade.
12. **Cover fabric substitution is not allowed.** The installer should lay the Eljen provided geotextile cover fabric lengthwise down the row, with the fabric fitted to the perforated pipe on top of the GSF modules. Fabric should be neither too loose, nor too tight. The correct tension of the cover fabric is set by:
 - a. Spreading the cover fabric over the top of the module and down both sides of the module with the cover fabric tented over the top of the perforated distribution pipe.
 - b. Place shovelfuls of Specified Sand directly over the pipe area allowing the cover fabric to form a mostly vertical orientation along the sides of the pipe. Repeat this step moving down the pipe.
13. Place 6 inches of Specified Sand along both sides of the modules edge. A minimum of 6 inches of Specified Sand is placed at the beginning and end of each module row. Beds on level sites require a minimum spacing of 12" of Specified Sand between parallel module rows with 24" of separation required on sites with 15% to 20% slope. No mechanical connection is required between modules.
14. Complete backfill with a minimum of 12 inches of clean, porous fill measured from the top of the pipe. Backfill exceeding 18 inches requires venting at the far end of the bed. Use well graded native soil fill that is clean, porous, and devoid of large rocks. Do not use wheeled equipment over the system. A light track machine may be used with caution, avoiding crushing, or shifting of pipe assembly.
15. Divert surface runoff from the system. Finish grade to prevent surface ponding. Topsoil and seed system area to protect from erosion.

5.0 Mound Installation Guidelines

5.1 MOUND REFERENCE: The following guidelines provide an overview for mound design and construction. Mound distribution can either be pump to gravity or pressurized. Systems with 2000 GPD or greater shall require pressure distribution in accordance with 310 CMR 15.231. Fill must extend 15 ft. beyond the edge of the module, measured from the top of the module. This applies to all four sides of the field. Use of an impermeable barrier in accordance with DEP rules can reduce this distance to 5 ft. before beginning 3:1 side slope.

FIGURE 12: CROSS SECTION – MOUND SYSTEM

*Note: Design Can Utilize Either B43 or A42 Modules

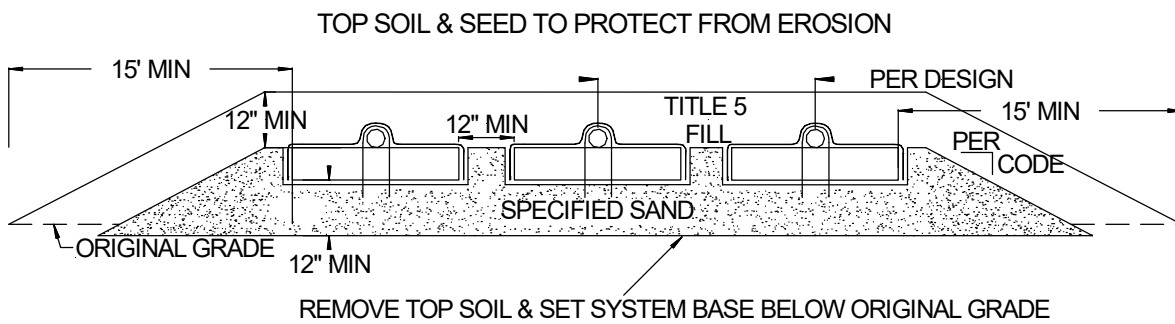
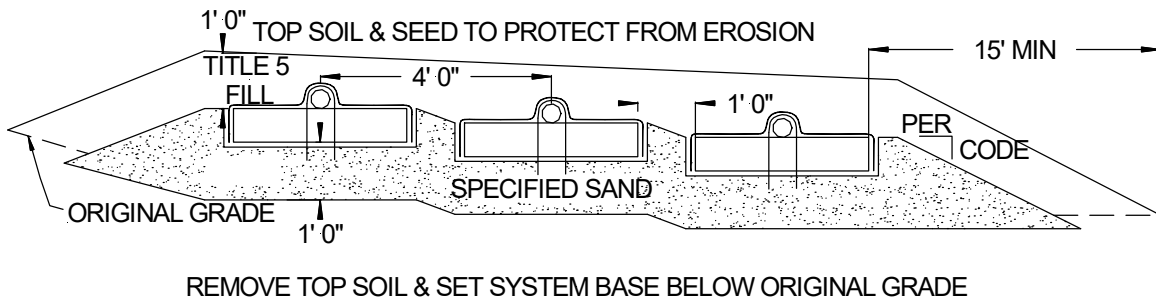

FIGURE 13: CROSS SECTION – SLOPED MOUND SYSTEM

*Note: Design Can Utilize Either B43 or A42 Modules



5.0 Mound Installation Guidelines

1. Ensure all components leading to the GSF system are installed properly. Septic tank effluent filters are required with the GSF system.
2. Determine the number of GSF Modules required using the sizing formula.
3. Prepare the site. Do not install a system on saturated ground or wet soils that are smeared during preparation. Keep machinery off infiltrative areas.
4. Plan all drainage requirements above (up-slope) of the system. Set soil grades to ensure that storm water drainage and ground water is diverted away from the absorption area once the system is complete.
5. Remove the organic soil layer. Prepare the receiving layer to maximize the interface between the native soil and Specified Sand. Minimize walking in the absorption area prior to placement of the Specified Sand to avoid soil compaction.
6. Place fill material meeting local requirements (or Specified Sand requirements) onto the soil interface as you move down the excavated area. Place specified sand in a 6" lift, stabilize by foot, a hand held tamping tool or a portable vibrating compactor. The stabilized height below the GSF module must shall meet the mound design requirements.
7. Place GSF modules with **PAINTED STRIPE FACING UP**, end to end on top of the specified sand along their 4-foot length.
8. A standard perforated 4-inch distribution pipe is centered along the modules 4-inch length. Orifices are set at the 4 & 8 o'clock position.
9. All distribution pipes are secured with manufacturers supplied wire clamps, one per module.
10. (Pressure Distribution Systems) Insert a PVC Sch. 40 pressure pipe (size per design and code) into the standard perforated distribution pipe. The pressure pipe orifices are set at the 12 o'clock position as shown in Figure 14. Each pressure lateral will have a drain hole at the 6 o'clock position. Each pressure lateral shall include sweeping cleanouts at the terminal ends and be accessible from grade.
11. **Cover fabric substitution is not allowed.** The installer should lay the Eljen provided geotextile cover fabric lengthwise down the row, with the fabric fitted to the perforated pipe on top of the GSF modules. Fabric should be neither too loose, nor too tight. The correct tension of the cover fabric is set by:
 - a. Spreading the cover fabric over the top of the module and down both sides of the module with the cover fabric tented over the top of the perforated distribution pipe.
 - b. Place shovelfuls of Specified Sand directly over the pipe area allowing the cover fabric to form a mostly vertical orientation along the sides of the pipe. Repeat this step moving down the pipe.
12. Ensure there is 6 inches of specified sand surrounding the GSF modules in the mound. Slope the sand away from the mound as described on the plan.
13. Complete backfill with a minimum of 12 inches of cover material measured from the top of the module. Use well graded native soil fill that is clean, porous, and devoid of large rocks. Do not use wheeled equipment over the system. A light track machine may be used with caution, avoiding crushing, or shifting of pipe assembly. Divert surface runoff from the system. Finish grade to prevent surface ponding. Topsoil and seed system area to protect from erosion.
14. Divert surface runoff from the system. Finish grade to prevent surface ponding. Topsoil and seed system area to protect from erosion.

6.0 Dosing Distribution Guidance

6.1 PUMP TO DISTRIBUTION BOX: Specify an oversized distribution box for pumped dosed systems. Provide velocity reduction in the d-box with a tee or baffle. Set d-box outlets at the same elevation to equalize flow to each line or use drop boxes at the head of each line for serial distribution. If the absorption area is installed deeper than 18 inches, the system must be vented. See section 8.0 of this manual for detailed information on venting of systems.

6.2 DOSING DESIGN AND FLOW RATE: Dosing volume must be set to deliver a maximum of 4 gallons per B43 Module and 3 gallons per A42 Module per dosing cycle. Higher flow rates and short dose cycle push the effluent down the line and thus disperse the effluent over a larger area. A valve on the force main is recommended to set the flow rate so that the outlet pipes are submerged but prevents the d-box from overflowing.

7.0 Pressure Distribution Guidance

7.1 PRESSURE DISTRIBUTION: Dosing with small diameter pressurized laterals is acceptable for GSF systems. The pipe networks must be engineered and follow principles established for pressure distribution. Using pipe-in-pipe networks as shown in Figure 14, the orifice size and spacing of 3/16 inch and 4 feet is respectively recommended. On sloping sites, the orifices should be offset by 2 feet on each line. For example, the orifice on line one may be at 1 ft, 5 ft, 9 ft etc. with the next line at 3 ft, 7 ft, 11 ft etc. Flushing ports are required to maintain the free flow of effluent from orifices at the distal ends of each lateral. Contact Eljen's Technical Resource Department at 1-800-444-1359 or info@eljen.com for more information on pressure distribution systems.

Standard procedures for design of pressure distribution networks apply to the GSF filter. A minimum orifice size according to the regulations shall be maintained. A drain hole is required at the 6 o'clock position of each pressure lateral for drainage purposes. The lateral pipe network, constructed of PVC Sch. 40 pipe (size per design and code), is placed within a standard 4-inch perforated pipe. The perforation in the 4-inch outer pipe are set at the 4 and 8 o'clock position, the drilled orifices on the pressure pipe are set to spray at the 12 o'clock position directly to the top of the 4-inch perforated pipe as shown below. Pressure clean outs are required at the end of each lateral.

FIGURE 14: PRESSURE PIPE PLACEMENT

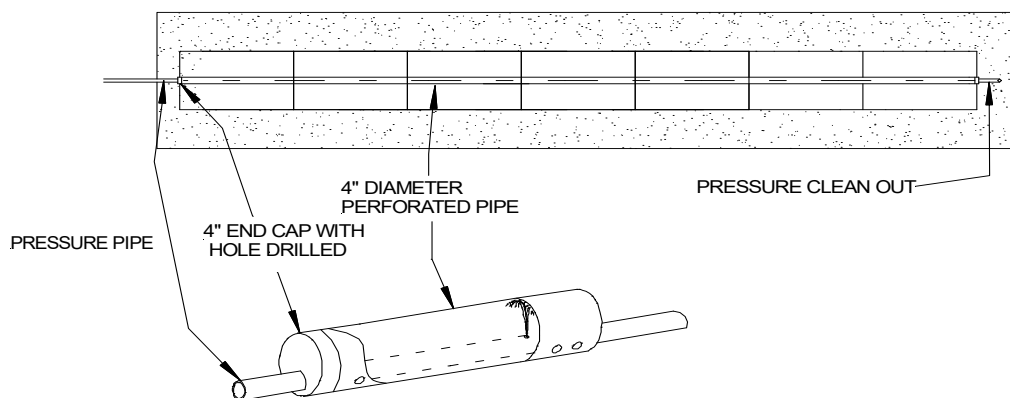

PRESSURE PIPE CROSS SECTION FOR ALL APPLICATIONS

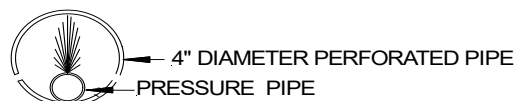

7.0 Pressure Distribution Guidance

FIGURE 15: PRESSURE CLEAN OUT

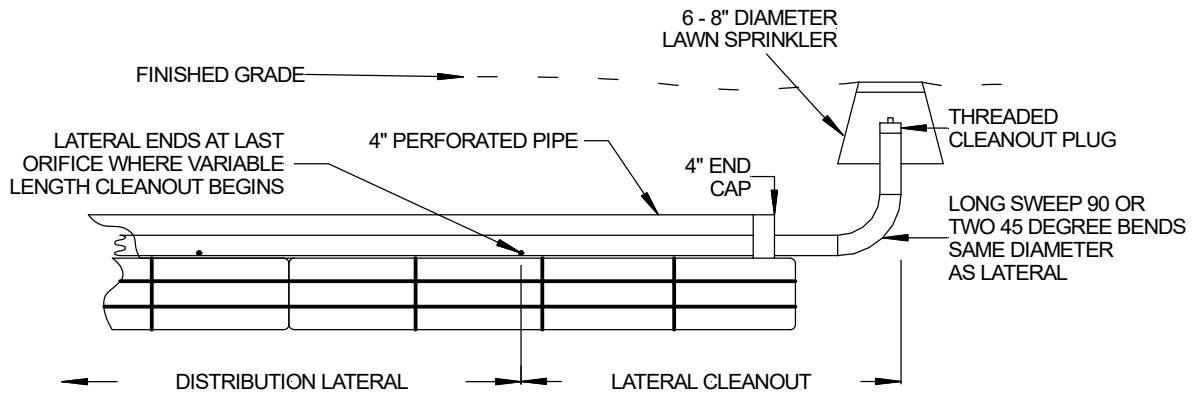
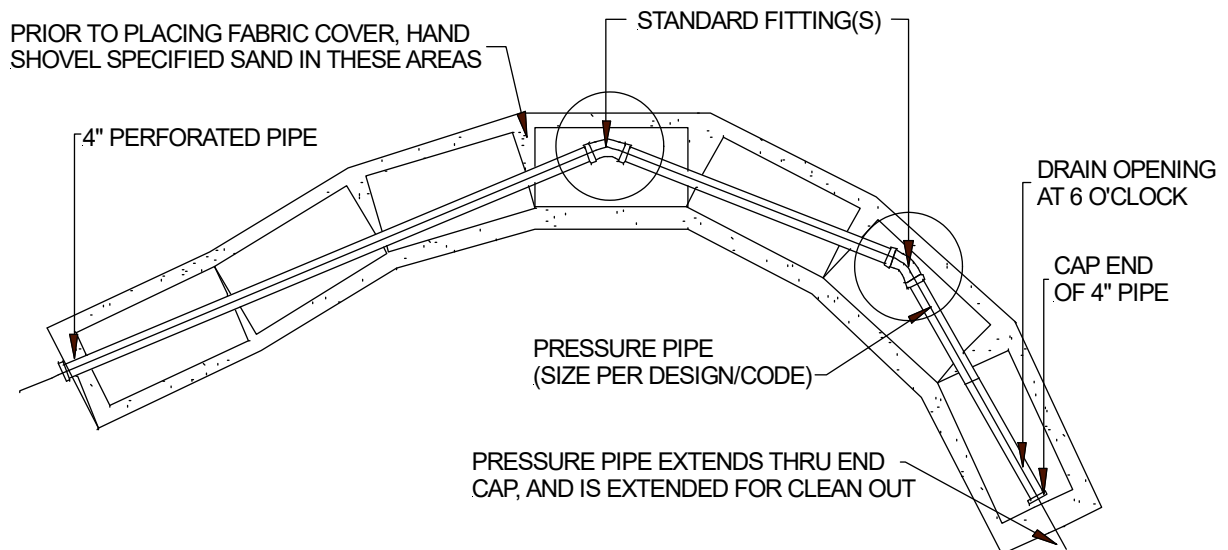

FIGURE 16: CONTOURED TRENCH PRESSURE DISTRIBUTION



GSF Pressure Distribution trench placed on a contour or winding trenches to maintain horizontal separation distances may also be used in Dosed or Gravity system by removing the pressure pipe and using the 4-inch diameter perforated distribution pipe.

8.0 System Ventilation

8.1 SYSTEM VENTILATION: Air vents are required on all absorption systems located under impervious surfaces or systems **with more than 18 inches of cover material** as measured from the top of the GSF module to finished grade. This will ensure proper aeration of the modules and sand filter. The GSF has aeration channels between the rows of GSF modules connecting to cuspatations within the GSF modules. Under normal operating conditions, only a fraction of the filter is in use. The unused channels remain open for intermittent peak flows and the transfer of air.

8.2 VENT PIPE FOR GRAVITY AND LOW-PRESSURE SYSTEMS: Systems with over 18" of cover over the top of the modules require a vent. If the system is a low-pressure distribution system, ensure that the LPP clean outs are located in the vent for easy access.

FIGURE 17: VENT LAYOUTS FOR GRAVITY AND LOW-PRESSURE SYSTEMS

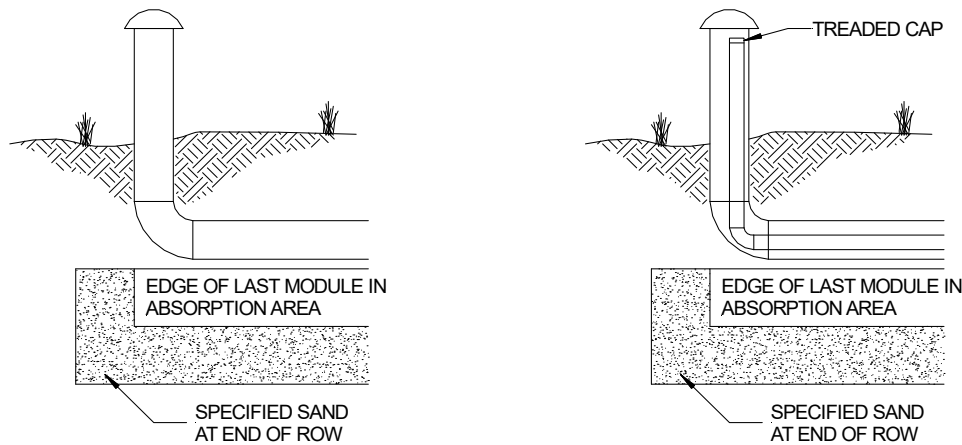

8.3 VENTILATION PLACEMENT: In a GSF system, the vent is usually a 4-inch diameter pipe extended to a convenient location behind shrubs, as shown in the figure below. Corrugated pipe may be used. If using corrugated pipe, ensure that the pipe does not have any bends that will allow condensation to pond in the pipe. This may close off the vent line. The pipe must have an invert higher than the system so that it does not drain effluent.

FIGURE 18: GSF WITH 4" VENT EXTENDED TO CONVENIENT LOCATION

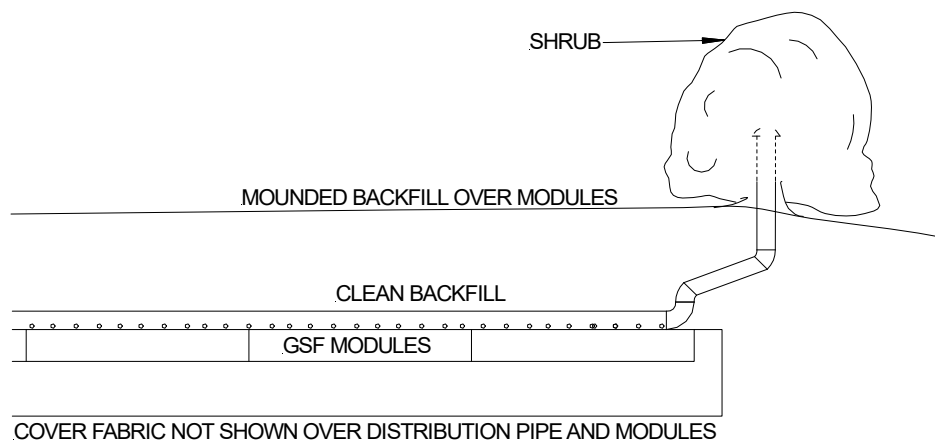

COMPANY HISTORY

Established in 1970, Eljen Corporation created the world's first prefabricated drainage system for foundation drainage and erosion control applications. In the mid-1980s, we introduced our Geotextile Sand Filter products for the passive advanced treatment of onsite wastewater in both residential and commercial applications. Today, Eljen is a global leader in providing innovative products and solutions for protecting our environment and public health.

COMPANY PHILOSOPHY

Eljen Corporation is committed to advancing the onsite industry through continuous development of innovative new products, delivering high quality products and services to our customers at the best price, and building lasting partnerships with our employees, suppliers, and customers.



90 Meadow Road, Windsor, CT 06095 • Tel: 800-444-1359 • Fax: 860-610-0427

www.eljen.com

