

**Commonwealth of Massachusetts**  
**Executive Office of Energy & Environmental Affairs**  
**DEPARTMENT OF ENERGY RESOURCES**  
**ALTERNATIVE ENERGY PORTFOLIO STANDARD**

**GUIDELINE**

**ON METERING AND CALCULATING THE USEFUL THERMAL OUTPUT OF ELIGIBLE  
RENEWABLE THERMAL GENERATION UNITS – PART 2**

**December 29, 2017**

*Pursuant to the Alternative Energy Portfolio Standard Regulations at 225 CMR 16.00*

This Guideline provides the methods by which the thermal output of intermediate and large Renewable Thermal Generation Units (RTGUs) qualified for the Alternative Energy Portfolio Standard (APS) shall be metered and how the meter readings are to be used in conjunction with the APS renewable thermal alternative energy credit formula to determine the number of Alternative Energy Credits (AECs) generated. This document is Part 2 of the Guideline on Metering and Calculating the Useful Thermal Output of Eligible Renewable Thermal Generation Units, Part 1 of the guideline can be found at the link below.<sup>1</sup> A Table of Contents, Table of Figures, and List of Tables can be found immediately following this section.

The purpose of this Guideline is to ensure uniform, accurate, reliable, and verifiable measurements of RTGU performance for determination of APS benefits, as appropriate to RTGU size and expense.

This Guideline is effective immediately upon issuance. However, the Department of Energy Resources (Department) may consider exceptions from the Guideline in the case of RTGUs that went into commercial operation prior to the issuance date, but not earlier than January 1, 2015.

---

<sup>1</sup> Part 1 of the Guideline on Metering and Calculation the Useful Thermal Output of Eligible Renewable Thermal Generation Units can be found at <https://www.mass.gov/files/documents/2017/12/14/Guideline%20on%20Metering%20and%20Calculating%20Useful%20Thermal%20Output%20of%20Eligible%20Renewable%20Thermal%20Generation%20Units-%20Part%201%20FINAL.pdf>

## Table of Contents

1) Provisions in the Statute and Regulations .....	6
2) Applicability .....	7
3) Metering Requirements and Formulae for Intermediate and Large RTGUs.....	9
A) General .....	9
1) Quantification of Parasitic Thermal Energy .....	11
2) Non Useful Thermal Energy .....	11
3) Locating Btu Meters .....	11
4) Measuring the Net Renewable Thermal Energy Transferred to a Useful Thermal Load .	12
B) General Formulae for the Quantification of Useful Thermal Energy .....	12
C) Metering Information .....	13
1) Acquisition, Recording, Storing, and Transmittal of Metered Data .....	13
2) Meter Standards .....	13
3) Thermal Energy Meters .....	14
4) Fuel Meters .....	16
5) Electric Meters .....	17
6) Accuracy of Thermal and Fuel Metering.....	17
7) Re-calibration of APS meters .....	17
D) Intermediate and Large Solar Hot Water Systems .....	18
1) Major System Components.....	18
2) Meters .....	18
3) Data Acquisition System(s) (DAS).....	18
4) Metering of Intermediate Solar Thermal RTGUs.....	19
5) Formula for Intermediate Solar Thermal RTGUs.....	20
6) Metering of Large Solar Thermal RTGUs.....	21
7) Formula for Large Solar Thermal RTGUs.....	22
8) Transpired Solar Air Collector (TSAC) Systems .....	22
9) Data Acquisition System(s) (DAS) for Intermediate TSAC RTGUs .....	23
10) Metering for Intermediate TSAC RTGUs .....	23
11) Formula for an Intermediate TSAC RTGU .....	24

12) Metering for Large TSAC RTGUs .....	26
13) Formula for a Large TSAC RTGUs.....	27
E) Intermediate and Large Air Source Heat Pump Systems .....	27
1) Direct Expansion (DX) Air Source Heat Pumps (ASHPs).....	27
2) Metering for Intermediate DX ASHPs .....	28
3) Formula for Intermediate DX ASHPs.....	29
4) Metering of Large DX ASHPs.....	30
5) Formula for Large DX ASHPs .....	30
6) Split or Variable Refrigerant Flow (VRF) ASHPs .....	31
7) Metering for Intermediate Split or VRF ASHPs.....	32
8) Formula for Intermediate Split or VRF ASHPs.....	32
9) Metering for Large Split or VRF ASHPs .....	34
10) Formula for Large Split or VRF ASHPs.....	35
F) Intermediate and Large Ground Source Heat Pump Systems .....	36
1) Metering for Intermediate GSHPs .....	37
2) Formula for Intermediate GSHPs .....	37
3) Metering for Large GSHPs .....	39
4) Formula for Large GSHPs .....	39
G) Intermediate and Large Fired Systems .....	40
1) Fired RTGUs which are Combined Heat and Power (CHP) Systems .....	41
2) Thermal Storage.....	42
3) Metering for Intermediate Fired RTGUs, which Generate a Hot Heat Transfer Fluid and/or Steam .....	42
4) Formula for Intermediate Fired RTGUs .....	44
5) Firing Modes for Intermediate Fired RTGUs .....	44
6) Determination of RH for Intermediate RTGUs That Are Not CHP Systems.....	45
7) Intermediate Fired CHP RTGUs.....	45
8) Large Fired RTGUs which Generate a Hot Heat Transfer Fluid.....	46
9) Metering for Large Fired RTGUs which Generate a Hot Heat Transfer Fluid .....	46
10) Formulae for a Large, RTGU Generating a Hot Heat Transfer Fluid .....	47
11) Firing Modes.....	48
12) Large Fired RTGU which Generate Steam.....	49

13) General Metering Requirements for Large RTGUs Generating Steam .....	50
14) Formula for Large RTGUs Generating Steam .....	51
H) Compost Vapor Heat Recovery RTGUs .....	54
1) Major Components.....	54
2) Metering for Compost Vapor Heat Recovery RTGUs .....	55
3) Formula for Compost Vapor Recovery RTGUs .....	56
4) Miscellaneous .....	57

### Table of Figures

Figure 1. Diagram of a generic central RTGU with Distributed Thermal Loads .....	12
Figure 2. Simplified Schematic of a Generic Intermediate Size Solar Thermal RTGU .....	19
Figure 3. Simplified Schematic of a Generic Large Solar Thermal RTGU .....	21
Figure 4. Simplified Schematic of a Generic Intermediate TSAC RTGU .....	23
Figure 5. Simplified Schematic of a Generic, Large TSAC RTGU .....	26
Figure 6. Metering Diagram for an Intermediate DX ASHP .....	28
Figure 7. Metering Diagram for a Large DX ASHP .....	30
Figure 8. Metering Diagram for an Intermediate Split or VRF ASHP .....	32
Figure 9. Metering for Large VRF ASHPs .....	34
Figure 10. Metering Diagram for an Intermediate GSHP .....	37
Figure 11. Metering Diagram for a Large GSHP .....	39
Figure 12. Metering Diagram for an Intermediate Fired RTUG (Both Hot HTF and Steam) .....	43
Figure 13. Metering Diagram for a Large Fired RTUG which Generates a Hot Heat Transfer Fluid .....	47
Figure 14. Simplified Schematic Diagram of a Generic Large RTGU Generating Steam .....	51
Figure 15. Simplified Schematic Diagram of a Compost Vapor Heat Recovery RTGU .....	55

### List of Tables

Table 1: APS Renewable Thermal Generation Unit Classification .....	8
Table 2. Thermal Energy Meter Requirements for Steam .....	14
Table 3. Thermal Energy Meter Requirements for Hot Water .....	15
Table 4. Thermal Energy Meter Requirements for Air .....	15
Table 5. Thermal Energy Meter Requirements for Refrigerants .....	15
Table 6. Fuel Meter Requirements for Natural Gas .....	16
Table 7. Fuel Meter Requirements for Biogas .....	16
Table 8. Fuel Meter Requirements for Liquid Fuels .....	17

## 1) **Provisions in the Statute and Regulations**

The Alternative Energy Portfolio Standard (APS) statute at M.G.L. Chapter 25A, Section 11F½ (a)<sup>2</sup>, as amended by Chapter 251 of the Acts of 2014, mandates the following as an eligible Alternative Energy Generating Source (emphasis added as italics):

(iv) any facility that generates useful thermal energy using sunlight, biomass, biogas, liquid biofuel or naturally occurring temperature differences in ground, air or water, whereby 1 megawatt-hour of alternative energy credit shall be earned for every 3,412,000 British thermal units of net useful thermal energy produced and *verified through an on-site utility grade meter or other means satisfactory to the department*;

Pursuant to the verification provision in that language, the APS regulations state the following at 225 CMR 16.05(4):

(b) Metering Requirements. The net Useful Thermal Energy output from an APS Renewable Thermal Generation Unit shall be metered according to the specifications laid out in the Department's *Guideline on Metering and Calculating the Useful Thermal Output of Eligible Renewable Thermal Generation Units* and verified by an independent Third Party Meter Reader as defined in Rule 2.5(j) of the NEPOOL GIS Operating Rules and approved by the Department. The APS Alternative Generation Attributes reported to the NEPOOL GIS by an independent Third Party Meter Reader shall be the amount as specified in 225 CMR 16.05(1)(a)6.b. This amount will be inclusive of any netting of energy use by the APS Renewable Thermal Generation Unit as prescribed in 225 CMR 16.05(1)(a)6.b.iii., and the application of any multiplier identified in the Department's *Guideline on Multipliers for Renewable Thermal Generation Units*.

(1) An APS Renewable Thermal Generation Unit that uses more than one eligible technology in 225 CMR 16.05(1)(a)6.a. is required to use the same independent Third Party Meter Reader for all technologies.

(2) Each APS Renewable Thermal Generation Unit is required to have its own individual NEPOOL GIS asset. An APS Renewable Thermal Generation Unit that uses more than one eligible technology in 225 CMR 16.05(1)(a)6.a. is required to have a NEPOOL GIS asset for each technology. APS Renewable Thermal Generation Units that utilize the same technology and are located in the same state may qualify as an Aggregation and share a NEPOOL GIS asset.

---

<sup>2</sup> The APS statute is available at <https://malegislature.gov/Laws/GeneralLaws/PartI/TitleII/Chapter25A/Section11F1~2>. These were amended by sections 1, 2, 3, and 9 of [Chapter 251 of the Acts of 2014](#).

This Guideline specifies the manner by which the output of RTGUs can be verified through on-site meters which meet the minimum APS metering requirements as described in Section 3 of this document, or other means as specifically approved by the Department on a case by case basis.

## 2) **Applicability**

This document provides general guidance on the type, number, and location of meters specific to each type of RTGU eligible under the APS. The Department strongly suggests that information showing the number, type, and location of meters to be installed, be submitted to the Department for preliminary review prior to the issuance of for bid or for construction designs and/or before procurement of the meters.

All direct measurements of energy are to be done by meters which comply with the requirements as set forth in Section 3 of this Guideline. The Department has determined that it is appropriate, practical, and non-burdensome to require that large RTGUs be fully and directly metered and that a reduced level of direct metering combined with indirect metering is required for intermediate sized RTGUs.

The ongoing operation of all RTGUs will be verified through means appropriate for each. Additionally, the Department has determined that a subset of large RTGUs that use biomass, biofuels, or biogas can be accurately metered by using fuel input recording, in combination with the RTGU's energy conversion efficiency and fuel energy content.

225 CMR 16.05(4)(a) and Table 1 below summarize how RTGUs will be classified based on their capacity and defines the cut-off points for distinguishing between small, intermediate, and large RTGUs. The size thresholds apply to the total combined capacity of the RTGU serving the thermal load. If an RTGU consists of several individual separate units, their capacities will be summed and the total capacity will be considered against the size threshold. In the case of a combination of solar thermal and other RTGUs, the thresholds will be applied separately to the solar and non-solar RTGUs.

**Table 1: APS Renewable Thermal Generation Unit Classification**

Classification	Small	Intermediate		Large
		Calculated net renewable thermal based on <u>indirect</u> metering	Calculated net renewable thermal output based on <u>direct</u> metering of fuel input	
<b>AEC calculation basis</b>	<b>Calculated net renewable thermal output</b>	<b>Calculated net renewable thermal based on <u>indirect</u> metering</b>	<b>Calculated net renewable thermal output based on <u>direct</u> metering of fuel input</b>	<b>Metered net renewable thermal output</b>
<b>Solar thermal: evacuated tube and flat plate solar hot water</b>	Collector surface area less than or equal to 660 sq ft	Collector surface area between 660 and 4000 sq ft	-	Collector surface area greater than or equal to 4000 sq ft
<b>Solar thermal: solar hot air</b>	-	Collector surface area less than or equal to 10,000 sq ft	-	Collector surface area greater than 10,000 sq ft
<b>Solar sludge dryer</b>	-	-	-	All
<b>Eligible Biomass Fuel</b>	-	-	Capacity less than or equal to 1 MMBtu per hour	Capacity greater than 1 MMBtu per hour
<b>Compost heat exchange system</b>	-	-	-	All
<b>Air source heat pump: electric motor or engine driven</b>	Output capacity less than or equal to 0.134 MMBtu per hour	-	Output capacity between 0.134 and 1.00 MMBtu per hour	Output capacity greater than or equal to 1.0 MMBtu per hour
<b>Ground source heat pump</b>	Output capacity less than or equal to 0.134 MMBtu per hour	-	Output capacity between 0.134 and 1.00 MMBtu per hour	Output capacity greater than or equal to 1.0 MMBtu per hour
<b>Deep geothermal</b>	-	-	-	All

<sup>1</sup> Submetering of non-renewable fuel (e.g. gas or grid electricity) consumption will be used in conjunction with original equipment manufacturer performance data to calculate net thermal output for intermediate size air source heat pumps (ASHP), ground source heat pumps (GSHP), and solar thermal RTGUs.

<sup>2</sup> The thermal output and non-renewable fuel consumption are metered directly.



<sup>3</sup> All Biogas/Biofuel RTGUs must apply via an aggregator as described in section 4(H) below.

<sup>4</sup> Output heating capacity at entering source air temperature of 5°F

<sup>5</sup> The performance of intermediate and large air source heat pump units must be Air-Conditioning and Heating Institute (AHRI) certified.

<sup>6</sup> If AHRI Certificate exists, output heating capacity as indicated on the AHRI Certificate at Full Load. If AHRI Certificate does not exist, use manufacturer's rated output heating capacity as indicated below:

- (a) For closed loop, water to water heat pumps: capacity at source entering water temperature of 32°F and load entering water temperature of 104°F. If multiple ratings are shown under these conditions, use the source water and load water flow rate that results in the largest heating capacity.
- (b) For open loop water to water heat pumps: capacity at source entering water temperature of 50°F and load entering water temperature of 104°F. If multiple ratings are shown under these conditions, use the source water and load water flow rate that results in the largest heating capacity.
- (c) For closed loop, water to air heat pumps, capacity at source entering water temperature of 32°F and load entering air temperature of 70°F. If multiple ratings are shown under these conditions, use the source water and load air flow rate that results in the largest heating capacity.
- (d) For open loop, water to air heat pumps, capacity at source entering water temperature of 50°F and load entering air temperature of 70°F. If multiple ratings are shown under these conditions, use the source water and load air flow rate that results in the largest heating capacity.

For the purpose of this Guideline, the definition of closed loop and open loop are as follows:

Close loop: Any water to air or water to water ground source heat pump system having no direct contact between the groundwater and the system fluid used for heat exchange.

Open loop: Any water to air or water to water ground source heat pump system which uses groundwater as the fluid for heat exchange.

### **3) Metering Requirements and Formulae for Intermediate and Large RTGUs**

#### **A) General**

- The British Thermal Unit (Btu) is a unit of thermal energy commonly used in the quantification of the capacity of a RTGU, as well as for the input and output energy of a system and/or component.
- All of the energy terms in the APS formulae for the determination of AECs are to be expressed in megawatt hours (MWh).

- 1 Btu = 1/3.412 watt hour; 1 MMBtu = 1,000,000 Btu = 1/3.412 MWh
- Net useful heat is the thermal energy by a RTGU that is transferred to a facility and/or process load and is equal to the thermal energy supplied to the load from the RTGU minus thermal energy returned from the load to the RTGU minus any parasitic thermal energy.
- RTGUs which are Combined Heat and Power (CHP) Systems:

An RTGU which co-generates electricity and useful heat is designated as a CHP RTGU and may qualify for Massachusetts Portfolio Standard Programs and earn credits in one of two different ways:

- (a) A CHP RTGU may qualify as a Renewable Portfolio Standard (RPS) Class I generator and as an APS RTGU In this case:
  - (i) The net MWh electricity generated by the CHP RTGU earns Class I Renewable Energy Credits (RECs)
  - (ii) The net useful heat generated by the CHP RTGU earns one AEC per net MWh of useful heat transferred to a useful load
- (b) A CHP RTGU may qualify as a RPS Class I generator and as an APS CHP system per the regulations in CMR 225 16.00 that pertain to APS CHP systems and the related Guidelines. In this case:
  - (i) The net MWh of electricity generated by the CHP RTGU earns Class I RECs
  - (ii) The net MWh of electricity and the net MWh of useful heat generated by the unit earn AECs per the APS CHP formula as shown in the APS CHP regulations
- All electricity supplied by the ISO-NE grid to a RTGU including any auxiliary systems is considered to be non-renewable fuel and must be subtracted from the net useful heat generated. The amount of non-renewable source fuel per MWh of grid electricity consumed by a RTGU is equal to the MWh electricity consumed at the site divided by the most recently published ISO-NE marginal grid efficiency, which at the date of this version of this Guideline is 0.44 MWh source fuel/MWh electricity delivered.

The term auxiliary denotes a component and/or sub-system that does not directly generate Useful Thermal Energy, but whose operation is required in order for the generation of Useful Thermal Energy to occur. Examples of auxiliary components are:

- Boiler feedwater pumps
- Combustion air supply fans
- Biomass boiler stokers
- Solar thermal collector fluid circulating pumps

In general, components such as pumps, fans, blowers, etc. that may be installed and operated in conjunction with an RTGU whose function is to distribute the thermal energy generated by an RTGU to the useful thermal loads, are not considered as auxiliary and the energy required to operate them is not metered or included in the determination of AECs.

Exception: If a RTGU is located more than 500 ft. from the point of connection with a thermal load or with the thermal hosts' distribution system being supplied by the RTGU, the

grid sourced electricity supplied to circulate heat transfer fluid between a central RTGU and the point of connection with each remote building or self-contained load is to be subtracted from the net renewable useful heat transferred.

- Parasitic Energy is defined as the electricity or thermal energy that is generated by the RTGU which is used to operate any auxiliary component or system of the RTGU.

Parasitic electricity is typically applicable only to a CHP RTUG. Metering and quantification of parasitic electricity for CHP systems that qualify using option 1 or 2 ( see above) will conform as are applicable to the APS CHP and RPS Class 1 regulations and guidelines. Parasitic thermal energy may be applicable to all RTGUs; however it is typically limited to RTGUs which generate motive steam.

### 1) Quantification of Parasitic Thermal Energy

All efforts should be made to locate a system's Btu meters such that the consumption of parasitic thermal energy is netted out. In the event that this cannot be accomplished the parasitic thermal energy of any auxiliary system with a demand exceeding 5% of the projected value of the net annual AECs during nominal operating conditions will require either a calculation of the parasitic load or a separate Btu meter. This determination will be at the discretion of the Department.

### 2) Non Useful Thermal Energy

Renewable thermal energy that is rejected to a heat sink (e.g. the air, ground, surface, or storm water), or in most cases, to heat feedwater, is non Useful Thermal Energy and must be accounted for in the location of Btu meter instruments as well as in the determination of the net metered useful energy.

Wherever possible, the components of Btu meters should be located such that they do not count heat rejected to a heat sink or in most cases to heat feedwater, in the heat being metered as useful. If this is not possible, separate Btu metering will be required to measure the heat rejected to a heat sink and this energy shall be subtracted from the total metered Btus.

### 3) Locating Btu Meters

- a) Whenever possible, Btu meters should be located at a point before the interconnection with the load's thermal distribution system (i.e. on the RTGU side and not on the load side).
- b) Whenever possible, Btu meters should be located before any point of connection with a non-useful heat load, such as a radiator or cooling tower that rejects excess heat, before delivery to the distribution system, or rejection of excess heating systems.
- c) When a RTGUs is located more than 500 ft from the point of connection with a thermal load, the Btu meter(s) must be located within 30 feet from the point of connection to the thermal load

**Figure 1. Diagram of a generic central RTGU with Distributed Thermal Loads**

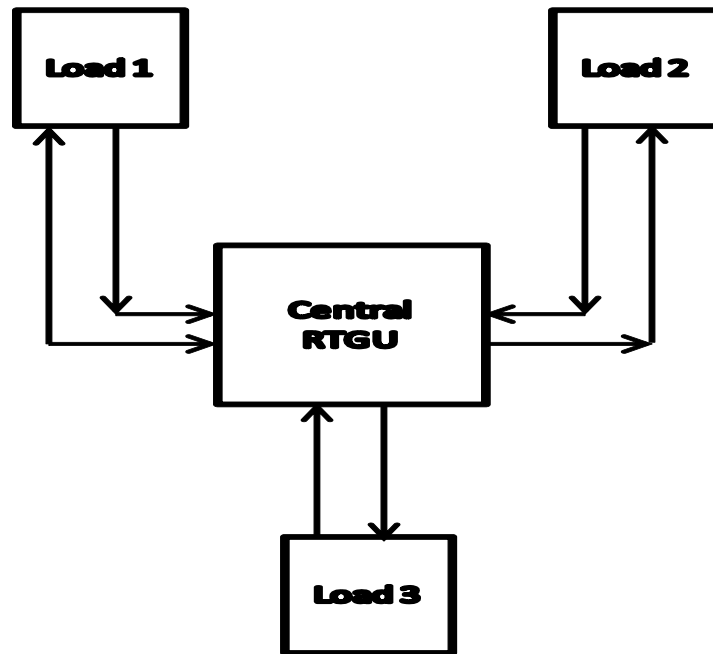

4) Measuring the Net Renewable Thermal Energy Transferred to a Useful Thermal Load

- (a) Air or Heat Transfer Fluids (including aqueous mixtures): based on mass flow, temperature, and specific heat
- (b) Steam: based on mass flow and specific enthalpy

**B) General Formulae for the Quantification of Useful Thermal Energy**

$$E_{\text{net, out}} = (RH - NUH - P_{\text{th}} - G/0.44)$$

*Note: All terms are the cumulative as-metered values. Unless otherwise indicated, all units in MWh*

Where:

$E_{\text{net, out}}$  = Net thermal energy output equivalent

RH = Net renewable heat transferred to a useful load

NUH = Non-useful heat

$P_{\text{th}}$  = Parasitic thermal energy

$G$  = Grid supplied electrical energy

Conversion of site to source nonrenewable fuel per MWh grid electricity =  $G / (0.44)$

### **C) Metering Information**

#### 1) Acquisition, Recording, Storing, and Transmittal of Metered Data

All RTGUs must include a data acquisition system (DAS) which must meet the following minimum functional criteria:

- (a) Input: Input must come from each APS metering system and component, at an interval that does not to exceed 5 minute between inputs
- (b) Storage: 100 days of cumulative input data
- (c) Output:
  - (i) Have remote electronic access to time stamped data of each input in five minute intervals that can be exported as a comma separated values (.csv) file
  - (ii) Data is to be accessible by and transferred directly to the system Independent Verifier and not via a third party

The DAS may be a stand-alone dedicated unit or be integrated into an existing system.

#### 2) Meter Standards

All meters required by the APS must meet and conform to all applicable laws, ordinances, codes, regulations, and standards, must be of revenue grade accuracy, quality, and reliability, and must have the capability to generate and transmit a signal to the system DAS.

3) Thermal Energy Meters

**Table 2. Thermal Energy Meter Requirements for Steam**

Line Size	Btu Meter System Components		System Field Accuracy	Re-Calibration Interval	Notes
	Flow Sensor and Btu Computer	Temperature & Pressure Sensors			
All	<i>Btu Computer:</i> Automated real-time computation and totalizer	—	±3%	Annual with Orifice Plate flow meter; Biennial with Vortex Shedding flow meter	—
≥8"	<i>Flow Sensor:</i> Orifice Plate with Differential Pressure Element and Transmitter	Only with superheated Steam			1) Perform an annual inspection of the flow sensor orifice plates and check for wear and distortion beyond the OEMs specifications as a part of the annual re-calibration procedure 2) If a significant percentage of flow occurs at flow rates below the flow sensors minimum guaranteed full accuracy flow rate, both the flow and Btus may be undercounted. This can be addressed by installing a two meter manifold with the meters sized to cover the entire expected range of flow rates. Consult the flow meter provider for design and installation details
< 8"	<i>Flow Sensor:</i> Vortex Shedding Tube	Only with superheated Steam			—

**Table 3. Thermal Energy Meter Requirements for Hot Water**

Btu Meter System Components	Btu Meter Field Accuracy	Re- Calibration Interval	Notes
<i>Flow Sensor:</i> In-line Ultrasonic Flow Tube (no strap-on) or Magmeter <i>Thermal Sensors:</i> Installed in thermowells <i>Btu Computer:</i> Automated real-time computation and totalizer	±3%	Biennial	No turbine or impellor based flow sensors

**Table 4. Thermal Energy Meter Requirements for Air**

Btu Meter System Components	Btu Meter Field Accuracy	Re- Calibration Interval	Notes
<i>Flow Sensor:</i> a) In-duct Differential Pressure Measuring Airflow Station b) Pitot Tube <i>Thermal Sensors:</i> Installed in the air flow stream <i>Btu Computer:</i> Automated real-time computation and totalizer	±3%**	Annual	Clean and inspect orifices as a part of the annual calibration procedure

*\*\*Computed accuracy of the metered Btus excludes the transfer of latent heat, which is calculated and added to the as metered value by the independent verifier based on hourly relative humidity measurements obtained from the NOAA Local Climatological Data available from the Land Based Station located closest to the RTGU.\*\**

**Table 5. Thermal Energy Meter Requirements for Refrigerants**

Btu Meter System Components	Btu Meter Field Accuracy	Re- Calibration Interval	Notes
<i>Liquid Flow Sensor:</i> Full Flow Ultrasonic (transit time) <i>Thermal Sensors:</i> RTD or Thermocouple Installed in thermowells <i>Btu Computer:</i> Automated real-time computation and totalizer	±3%	TBD	Care must be taken to avoid flashing of the hot liquid to vapor, which will affect the operation of expansion valves

4) Fuel Meters

In the event that one or more non-renewable fuels will be blended with one or more renewable fuels, the direct metering of each fuel is required.

**Table 6. Fuel Meter Requirements for Natural Gas**

Meter Type	Flow rate Range	Accuracy	Minimum Frequency of Calibration	Other
All Meters	$2\% \leq \text{Flowrate} \leq 100\% \text{ Max DF}$ Where Max DF is Maximum System Design Flow Rate	$\pm 2\%$	Annual	See Notes

Notes:

- 1) All diaphragm meters must conform to the current American National Standard Institute (ANSI) B109.2 standard
- 2) All rotary meters must conform to the current ANSI B109.3 standard
- 3) The default Higher Heating Value (HHV) for pipeline natural gas is 1,030 Btu per Standard Cubic Foot (SCF). Alternate HHVs may be proposed as documented by the fuel supplier
- 4) All volumetric measurements must be adjusted to SCF (i.e. they must be temperature and pressures corrected). Meter models that are auto pressure and temperature compensated will meet this requirement. Meters with a settable fixed value pressure compensation may be used if installed downstream of a pressure regulator. The applicant may propose and alternate method for converting the metered flow to SCF units
- 5) Thermal Diffusion Meters (TDM) are not approved
- 6) A pipeline gas meter furnished and installed as part of a dedicated gas line to the RTGU system by the site's gas utility will be accepted as an approved natural gas fuel meter
- 7) Submittal of a proposed meter other than as furnished by the site's gas utility should be accompanied by a list of utilities and/or distribution companies that have used the as-proposed meter either for billing or custody transfer.

**Table 7. Fuel Meter Requirements for Biogas**

Btu Meter System Components	Btu Meter Field Accuracy	Recalibration & Inspection Frequency	Notes
<p><i>Gas Flow Sensor:</i> Full Flow Averaging Pitot</p> <p>Real time gas analyzer</p> <p><i>Btu Computer:</i> Automated real-time computation and totalizer.</p>	$\pm 3\%$	Annual	Both tuned laser or infrared based optical gas analyzer technologies are acceptable



**Table 8. Fuel Meter Requirements for Liquid Fuels**

Meter Type	Flow rate	Accuracy	Minimum Frequency of Calibration	Other
Positive Displacement	Full Range	± 1%	Annual	See general and specific Notes.

5) Electric Meters

Electric (kWh) meters shall be revenue grade and shall:

- (a) Be certified as meeting American National Standard Institute (ANSI) Standard C12.20
- (b) Have a kW and kWh remote output signal with an output signal interval of not more than once per minute
- (c) Have either a non-resettable or password protected cumulative kWh register

6) Accuracy of Thermal and Fuel Metering

Thermal energy and fuel must be metered per the tables in 3(F) and 3(G) above, with a possible future modification per the issuance of the American Society for Testing and Materials (ASTM) Heat Meter Technology Standard WK37952 that is currently under development under the leadership of the United States Environmental Protection Agency (EPA).

7) Re-calibration of APS meters

The options for re-calibration of all APS meters are:

- (a) Remove the meter and have it re-calibrated either by the meter OEM or by a calibration shop that is approved by the meter OEM. If this option is selected, in order to be for the RTGU to be able to generate AECs during the interval in which an APS meter is removed for calibrations, either a temporary meter that meets the APS requirements must be installed or a proposed method and procedure to estimate the metered energy must be submitted to the DOER for approval prior to the removal of the meter.
- (b) The meter may be re-calibrated in situ providing that that this is done per instructions and procedures provided by the OEM and that the re-calibration is performed by a technician either directly provided by the OEM or approved by the OEM. Evidence that this conditions have been complied with must be included in the re-calibration report.

## **D) Intermediate and Large Solar Hot Water Systems**

### 1) Major System Components

Intermediate and large solar hot water RTGUs include, but are not limited to, the following major components:

- (a) A solar thermal energy collector system
- (b) One or more unfired water storage tanks that supply water, pre-heated by solar energy only, to a primary (fired) heating system
- (c) Heat exchanger(s) which transfer energy from the solar collector heat transfer fluid circulating loop to the volume of water in the pre-heat storage tank (not shown in Figure 2 below)
- (d) Electric motor driven pump(s) which circulate a heat transfer fluid in a closed loop between the solar collectors and the collector fluid-to-unfired storage tank heat exchanger
- (e) Automatic pump controller(s) which start and stop the circulating pumps based on a pre-set temperature difference between the temperature of the un-fired storage tank and the temperature of the solar collectors

### 2) Meters

All intermediate and large solar hot water RTGUs must have Btu and kWh meters as shown in Figure 2 and Figure 3.

### 3) Data Acquisition System(s) (DAS)

An eligible DAS must meet the requirements in Section 3(D) above record, store, and transmit time stamped Btu meter readings, and the run times of the collector heat transfer fluid circulating pump(s).

These are based on the generic configurations as shown in Figure 2 and Figure 3. The Department will evaluate metering plans and submittals based on alternative configurations on a case-by-case basis.

**Figure 2. Simplified Schematic of a Generic Intermediate Size Solar Thermal RTGU**

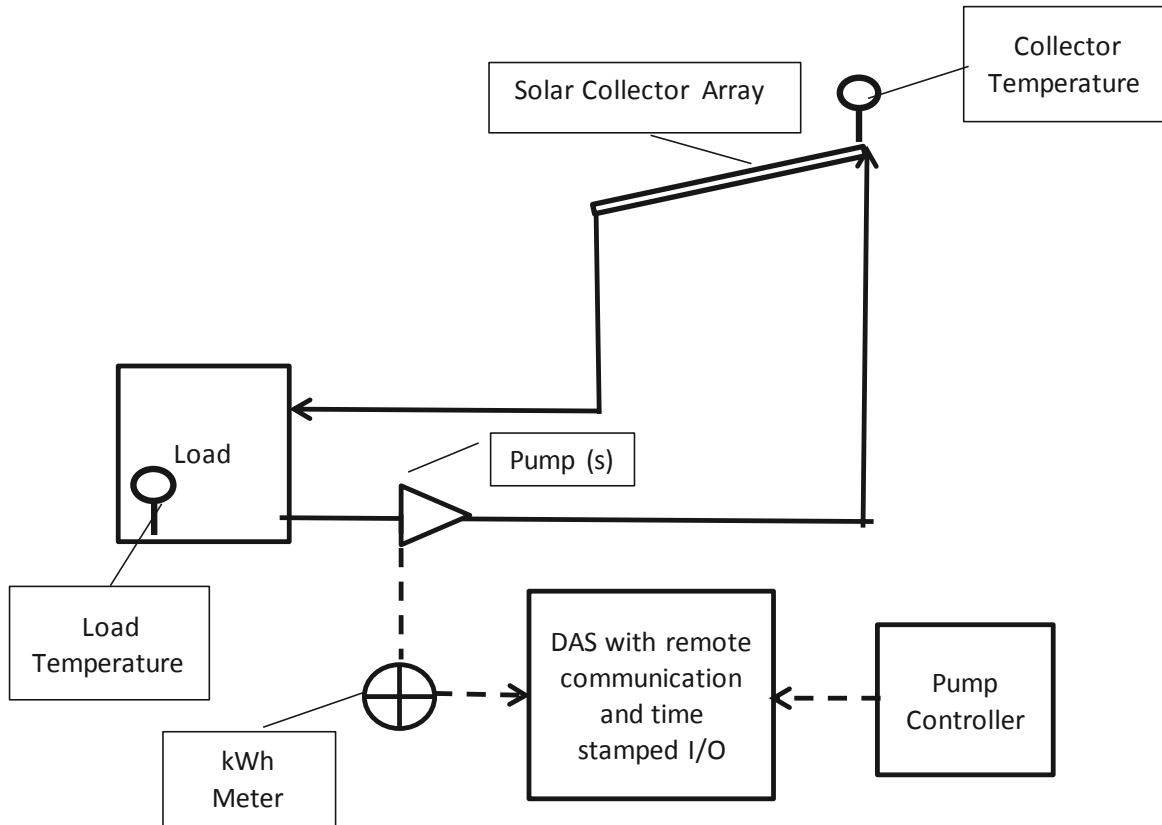

4) Metering of Intermediate Solar Thermal RTGUs

Refer to Figure 2 **Error! Reference source not found.**

- (a) The systems heat transfer fluid (HTF) supply temperature (HTFST) & HTF return temperature (HTFRT) will be measured directly with thermal sensors located at the collector array and the bottom of the unfired storage tank
- (b) Any grid supplied electrical energy (G) must be directly metered
- (c) After the circulating HTF system has set and balanced, the system flow rate will be determined and recorded by the installer using a temporary calibrated flow meter used to measure the flow rate for each pumped HTF loop. The temporary meter must be an in-line model and can be a turbine meter.

5) Formula for Intermediate Solar Thermal RTGUs

$$E_{\text{net, out}} = (RH - G/0.44)$$

and

$$AECs = E_{\text{net, out}} * M$$

Where:

$E_{\text{net, out}}$  = Net thermal energy output equivalent

RH = Net Renewable heat transferred to a useful load

G = Grid supplied electrical energy

M = The appropriate multiplier as defined in the *Department's Guideline on Multipliers for Renewable Thermal Generation Units*

*Note: All terms are the cumulative as-metered values. Unless otherwise indicated, all units are in MWh*

Determination of RH:

$$RH \text{ for any interval} = RH_{\text{supply}} - RH_{\text{return}}$$

Where:

$RH_{\text{supply}}$  = The renewable thermal energy supplied from the RTGU to the useful thermal load(s)

$RH_{\text{return}}$  = The renewable thermal energy returned from the useful thermal load the RTGU

The rate that RH transferred to the load at any time is:

$$HTFF * C_p * D * (HTFST - HTFRT)$$

Where:

HTFF = HTF flowrate (gpm)

$C_p$  = The constant pressure specific heat of the HTF (Btu/lb-°F)

D = Density of the HTF (lbs./gal)

HTFST = HTF supply temperature (°F)

HTFRT = HTF return temperature (°F)

6) Metering of Large Solar Thermal RTGUs

**Figure 3. Simplified Schematic of a Generic Large Solar Thermal RTGU**

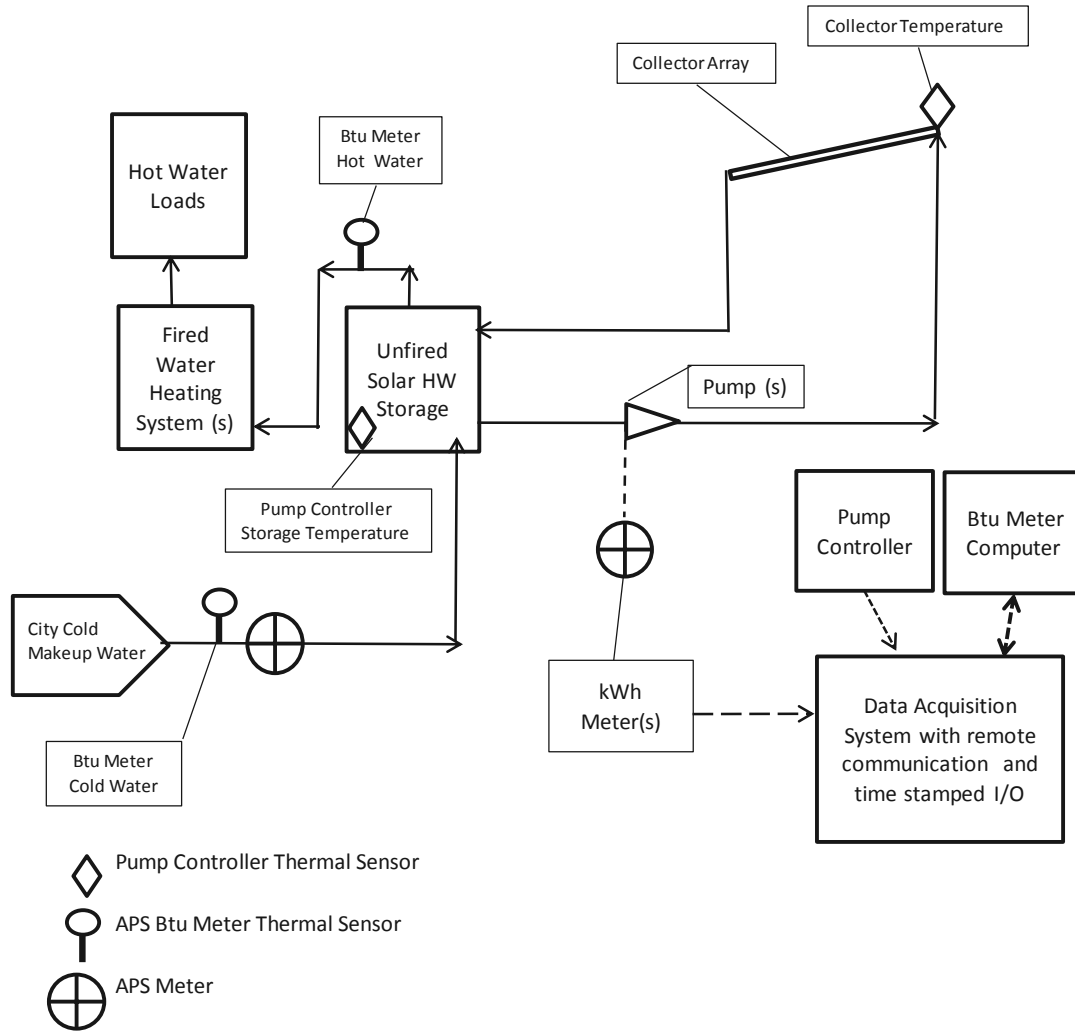

*Note: System heat exchangers not shown for clarity*

7) Formula for Large Solar Thermal RTGUs

$$E_{\text{net, out}} = (RH - G/0.44)$$

and

$$AECs = E_{\text{net, out}} * M$$

Where:

$E_{\text{net, out}}$  = Net thermal energy output equivalent

RH = Net Renewable heat transferred to a useful load

G = Grid supplied electrical energy

Conversion of site to source nonrenewable fuel per MWh grid electricity =  $G / (0.44)$

M = The appropriate multiplier as defined in the *Department's Guideline on Multipliers for Renewable Thermal Generation Units*

*Note: All terms are the cumulative as-metered values. Unless otherwise indicated, all units in MWh*

The rate that RH is transferred to the load at any time is:

$$(CMWF * 8.34 \text{ (lbs/gal)} * (TSHW - TCMW)) / 3.412E6 \text{ (Btu/MWh)}$$

Where:

CMWF = City cold makeup water flow rate (gallons per minute)

TCMW = Temperature of the city cold makeup water supply (°F)

TCMW = Temperature of the solar hot water supplied by the unfired solar storage tank to the fired hot water storage tank (°F)

8) Transpired Solar Air Collector (TSAC) Systems

TSAC RTGUs transfer solar energy to preheat the outside air supply to a heated space. Major system components for both intermediate and large TSAC RTGUs include, but are not limited to, the following major components:

- (a) Transpired Solar Air Collector(s)
- (b) Ducting from collector to ventilation unit
- (c) Bypass Air intake to ventilation
- (d) ON/OFF Solar Air Collector Damper and ON/OFF Bypass Air Damper

- (e) Automatic Controls
- (f) Ventilation Unit (Typically an existing Air Handling Unit, Make-Up Air Unit, In-Line Supply Fan)

9) Data Acquisition System(s) (DAS) for Intermediate TSAC RTGUs

An eligible DAS must meet the requirements in Section 3(D) above and record, store, and transmit time stamped Btu meter readings and the run times of the collector heat transfer fluid circulating pump(s).

These are based on the generic configurations as shown in Figure 4 and Figure 5. The Department will evaluate metering plans and submittals based on alternative configurations on a case-by-case basis.

10) Metering for Intermediate TSAC RTGUs

**Figure 4. Simplified Schematic of a Generic Intermediate TSAC RTGU**

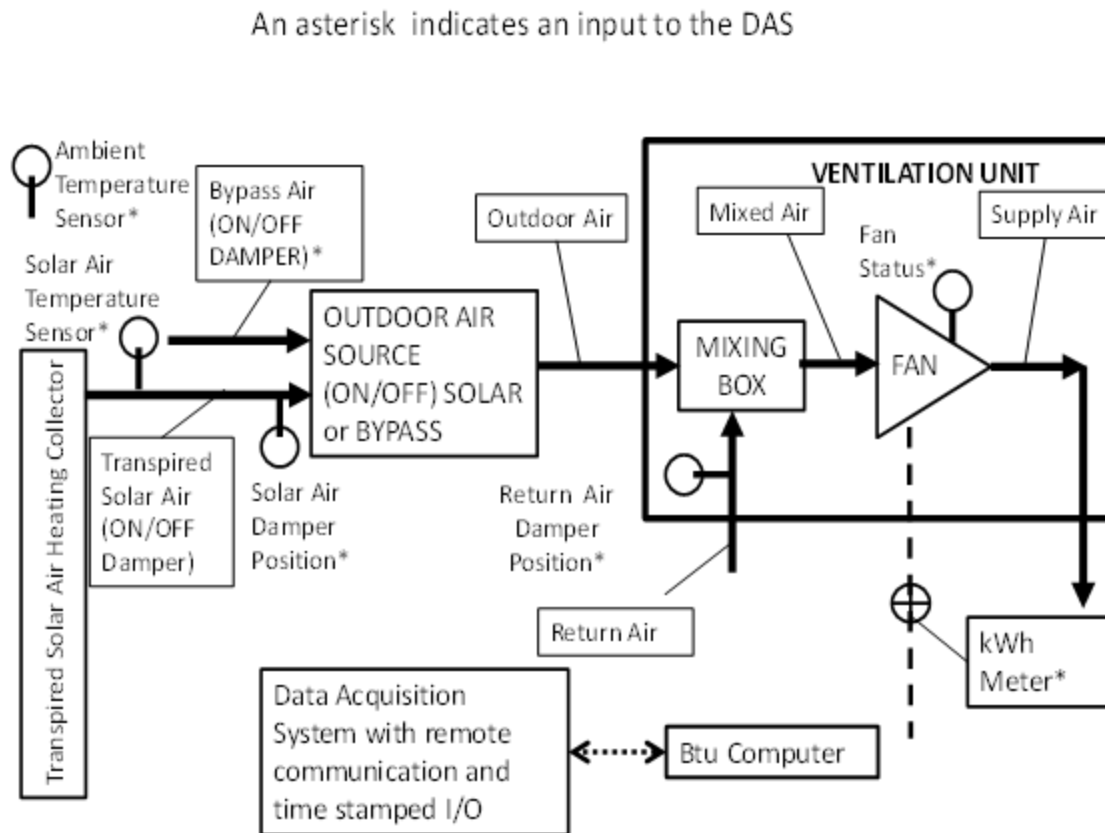

11) Formula for an Intermediate TSAC RTGU

$$E_{\text{net, out}} = \text{RH} - G/0.44$$

and

$$\text{AECs} = E_{\text{net, out}} * M$$

Where:

$E_{\text{net, out}}$  = Net thermal energy output equivalent

RH = Renewable heat transferred from the ambient air to a useful and is not directly metered

G = Grid supplied electrical energy

Conversion of site to source nonrenewable fuel per MWh grid electricity =  $G / (0.44)$

M = The appropriate multiplier as defined in the *Department's Guideline on Multipliers for Renewable Thermal Generation Units*

*Note: All terms are the cumulative as-metered values. Unless otherwise indicated, all units in MWh*

Determination of RH

$$\text{RH over any interval} = A * D * C_p * (T_{\text{TSA}} - T_{\text{AMBIENT}}) / 3.412E6 \text{ (Btu/MWh)}$$

Where:

A = Air Flow (cubic feet)

D = Density of Air (lbs/cf)

$C_p$  = Specific Heat Capacity of Air (Btu/lb -°F)

$T_{\text{TSA}}$  = Temperature of the hot air generated by the TSAC (°F)

$T_{\text{AMBIENT}}$  = Ambient Air Temperature (°F)

The TSAC RTGU hot air output flow rate is not directly metered. Whenever the TSAC RTGU by-pass damper is open and the existing system ventilation fan is running the outside air which is pre-heated by the TSAC RTGU is supplied to the space heating load.



The TSAC RTGU hot air output flow rate is indexed to the position of the return air damper(s) which sets the percentage of outside air supplied to the load that is mixed with the return air from the heated space.

During the initial test and balance section of the initial commissioning of the TSCA RTGU, the supplier will develop and provide a certified lookup table which indexes the flowrate of TSCA generated pre-heated air to the position of the return air damper from 0% to 100% open in increments of 5%. In order to maintain an approved status for a TSAC RTGU, the table will be re-calibrated on site, revised as needed and provided to the Department on an annual basis.

The rate of renewable heat transfer to a useful load at any time:

$$D * C_p * (T_{TSA} - T_{AMBIENT}) * DP_{SAH} * OAF * F_{STATUS}$$

Where:

D= Density of Air (lbs/cf)

C<sub>p</sub> = Specific Heat Capacity of Air (Btu/lb -°F)

T<sub>TSA</sub> = Temperature of the hot air generated by the TSAC (°F)

T<sub>AMBIENT</sub> = Ambient Air Temperature (°F)

DP<sub>SAH</sub> = TSAC RTGU By-pass damper position, (OPEN = 1, CLOSED = 0)

OAF = Flow rate of pre-heated air supplied by the TSAC RTGU as determined by the position of the return air damper

F<sub>STATUS</sub> = Ventilation Unit Fan Status (ON = 1, OFF = 0)

## 12) Metering for Large TSAC RTGUs

**Figure 5. Simplified Schematic of a Generic, Large TSAC RTGU**

An asterisk indicates an input to the DAS

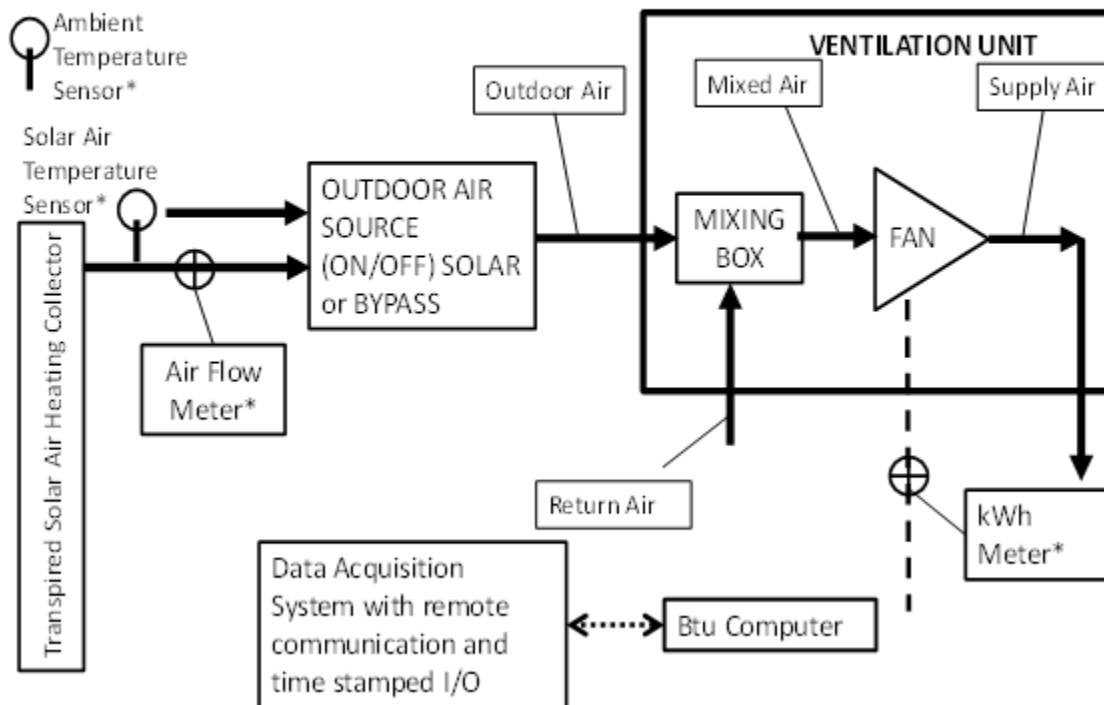

### 13) Formula for a Large TSAC RTGUs

$$E_{\text{net, out}} = \text{RH} - \text{G}/0.44$$

and

$$\text{AECs} = \text{M} * E_{\text{net, out}}$$

Where:

$E_{\text{net, out}}$  = Net thermal energy output equivalent

RH = Renewable heat transferred from the ambient air to a useful and is not directly metered

G = Grid supplied electrical energy

Conversion of site to source nonrenewable fuel per MWh grid electricity =  $G / (0.44)$

M = The appropriate multiplier as defined in the *Department's Guideline on Multipliers for Renewable Thermal Generation Units*

*Note: All terms are the cumulative as-metered values. Unless otherwise indicated, all units in MWh*

Determination of RH

$$\text{RH over any interval} = \text{A} * \text{D} * \text{Cp} * (\text{T}_{\text{TSA}} - \text{T}_{\text{AMBIENT}}) / 3.412\text{E}6 \text{ (Btu/MWh)}$$

Where:

A = Air Flow (cubic feet)

D = Density of Air (lbs/cf)

Cp = Specific Heat Capacity of Air (Btu/lb -°F)

$T_{\text{TSA}}$  = Temperature of the hot air generated by the TSAC (°F)

$T_{\text{AMBIENT}}$  = Ambient Air Temperature (°F)

## **E) Intermediate and Large Air Source Heat Pump Systems**

### 1) Direct Expansion (DX) Air Source Heat Pumps (ASHPs)

Both intermediate and large DX ASHPs will typically be a self-contained unit with a warm forced air output. The major components of a typical DX ASHP include, but are not limited to the following:

- (a) Controls
- (b) A closed refrigerant sub-system including:
  - (i) Compressor(s)
  - (ii) Evaporator(s)
  - (iii) Condenser(s)
  - (iv) JT expansion valves
  - (v) Refrigerant side tubing, instruments and control devices
- (c) An air side sub-system including:
  - (i) Fans
  - (ii) Louvers and dampers
  - (iii) Filters
  - (iv) Air flow related internal ducting, instruments, and control devices

2) Metering for Intermediate DX ASHPs

**Figure 6. Metering Diagram for an Intermediate DX ASHP**

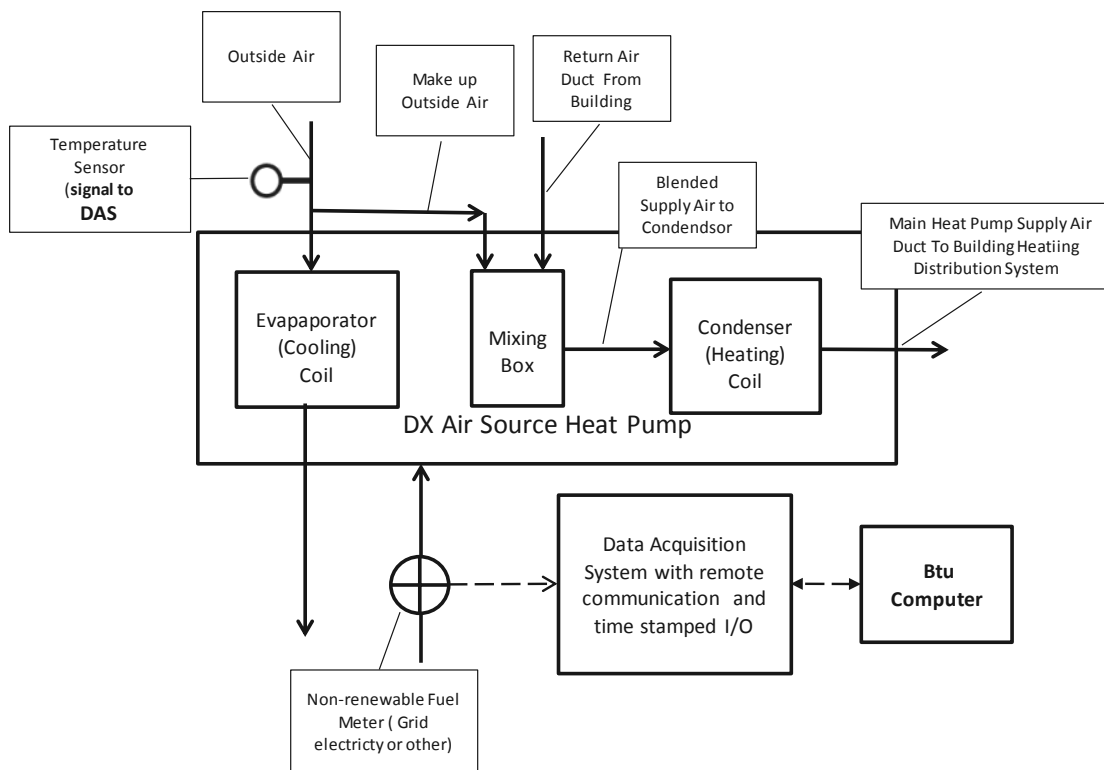

3) Formula for Intermediate DX ASHPs

$$E_{\text{net, out}} = (\text{COP}_{\text{OAT}} * G) - G/0.44$$

and

$$\text{AECs} = E_{\text{net, out}} * M$$

Where:

$E_{\text{net, out}}$  = Net thermal energy output equivalent

$\text{COP}_{\text{OAT}}$  = The book value of the coefficient of performance at the outside air temperature as measured at the RTGU

G = Grid supplied electrical energy

Conversion of site to source nonrenewable fuel per MWh grid electricity =  $G / (0.44)$

M = The appropriate multiplier as defined in the *Department's Guideline on Multipliers for Renewable Thermal Generation Units*

*Note: All terms are the cumulative as-metered values. Unless otherwise indicated, all units in MWh*

The  $\text{COP}_{\text{OAT}}$  for each five minute interval will be determined by the use of a lookup table provided by the RTGU's OEM on their letterhead. The table will show the COP of the RTGU for ambient outdoor temperatures between 5 and 50 deg. F.

The table is to be constructed as follows:

- (a) The  $\text{COP}_{\text{OAT}}$  performance data based on conformance with AHRI 210/240 is to be used
- (b) The  $\text{COP}_{\text{OAT}}$  data is subdivided into 15 deg. F intervals using a linear interpolation
- (c) The  $\text{COP}_{\text{OAT}}$  data is extended to 60 deg. F in 15 deg. F intervals by linear interpolation
- (d) Extension of the  $\text{COP}_{\text{OAT}}$  data below the lowest ambient temperature specified in the AHRI 210/240 to 5 deg. F in 10 deg. F intervals. This cannot be done by linear interpolation but must instead be developed and submitted by the OEM along with sufficient narrative detail to permit a review

*Note: The  $\text{COP}_{\text{OAT}}$  table will be used by the independent verifier together with the directly measured outside air temperature to compute the AECs for each operating month.*

4) Metering of Large DX ASHPs

**Figure 7. Metering Diagram for a Large DX ASHP**

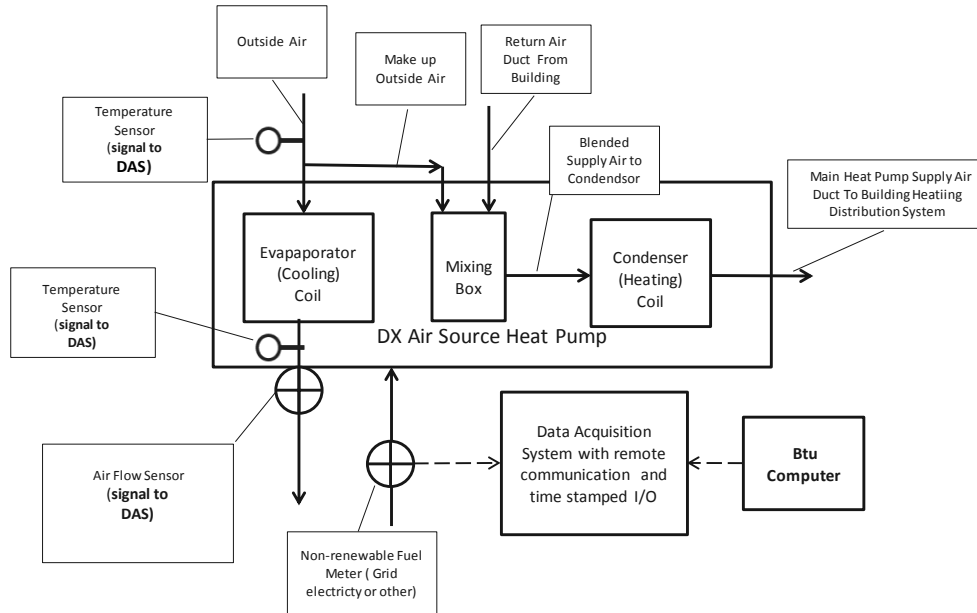

*Note: Only the components directly related to either the required APS metering or otherwise related to the terms of the AECs formula for DX ASHPs are shown*

5) Formula for Large DX ASHPs

$$E_{net, out} = (RH - G/0.44)$$

and

$$AECs = E_{net, out} * M$$

Where:

$E_{net, out}$  = Net thermal energy output equivalent

RH = Renewable heat transferred from the ambient air to the system and is directly metered

G = Grid supplied electrical energy

M = The appropriate multiplier as defined in the *Department's Guideline on Multipliers for Renewable Thermal Generation Units*

*Note: All terms are the cumulative as-metered values. Unless otherwise indicated, all units in MWh*

Conversion of site to source nonrenewable fuel per MWh grid electricity =  $G / (0.44)$

The rate of renewable heat transfer to a useful load is:

$$(AFC) * (h_{OA} - h_{LA})LA / 3.412E6 \text{ (Btu/MWh)}$$

Where:

AFC = Outside air flow rate (lbs/hr) through the Evaporator Section

$h_{OA}$  = Enthalpy of outside air (Btu/lb)\*\*

$h_{LA}$  = Enthalpy of air leaving the evaporator section (Btu/lb)\*\*

*\*\*The average real time hourly value for  $h_{OA}$  will be determined by the independent verifier based on hourly relative humidity measurements obtained from the NOAA Local Climatological Data available from the Land Based Station located closest to the RTGU. The NOAA web link for obtaining hourly relative humidity data for Land Based Stations in MA is: <https://www.ncdc.noaa.gov/cdo-web/datatools/lcd>. The value for  $h_{LA}$  will be calculated by the independent verifier using psychometric relationships based on the dry bulb temperature and relative humidity of the entering outside air and the metered dry bulb temperature of the leaving air. \*\**

#### 6) Split or Variable Refrigerant Flow (VRF) ASHPs

An intermediate or large split or VRF ASHP will typically be a split system consisting of an outdoor unit which generates hot refrigerant coupled with an indoor distribution system connected with one or more air handler or fan coil terminal units. A typical split or VRF ASHP includes, but is not limited to the following principal components:

- (a) Controls
- (b) A closed refrigerant sub-system including:
  - (i) Compressor(s)
  - (ii) Evaporator(s)
  - (iii) Condenser(s)
  - (iv) Refrigerant expansion valves
  - (v) Tubing, instruments and control devices
- (c) An air side sub-system including:
  - (i) Air handler unit(s)
  - (ii) Fan coil terminal units

7) Metering for Intermediate Split or VRF AHSPs

**Figure 8. Metering Diagram for an Intermediate Split or VRF ASHP**

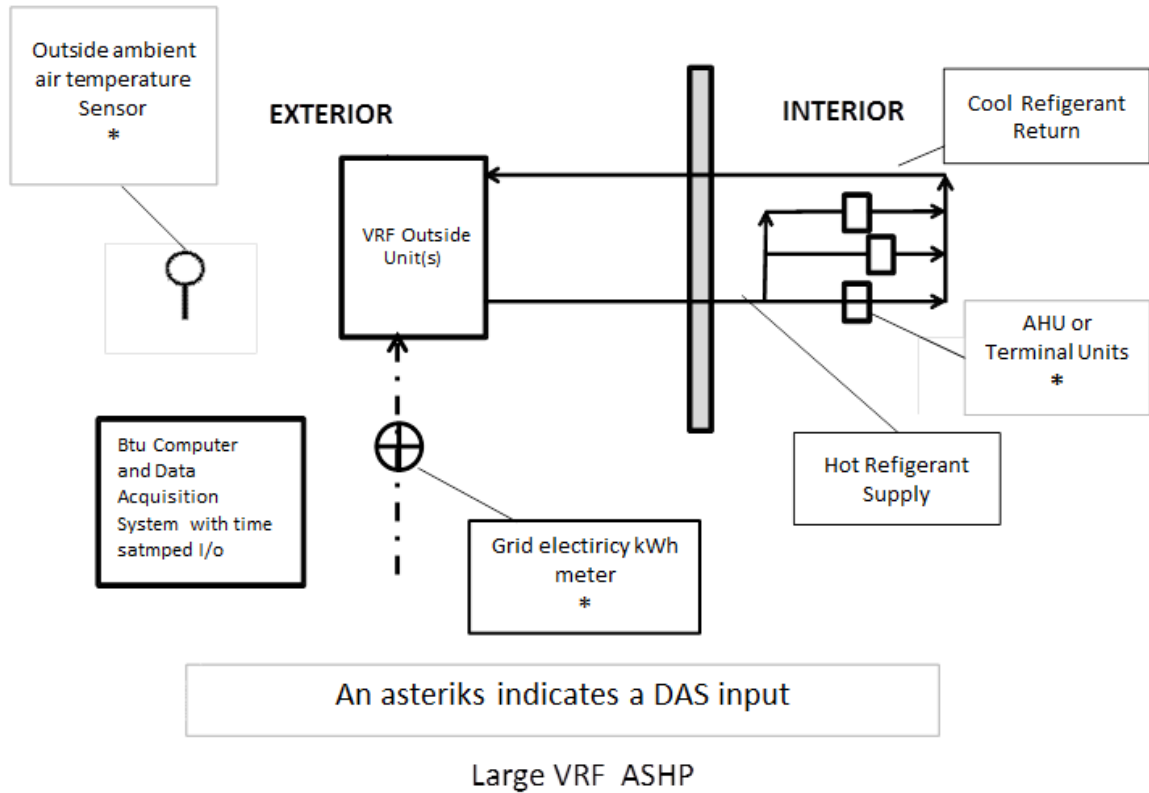

*Note: Only the components directly related to either the required APS metering or otherwise related to the terms of the AECs formula for VRF ASHPs are shown.*

8) Formula for Intermediate Split or VRF ASHPs

$$E_{net, out} = (COP_{OAT} * G) - G/0.44$$

and

$$AECs = E_{net, out} * M$$

Where:

$E_{net, out}$  = Net thermal energy output equivalent

$COP_{OAT}$  = The book value of the coefficient of performance at the outside air temperature as measured at the RTGU



G = Grid supplied electrical energy

Conversion of site to source nonrenewable fuel per MWh grid electricity =  $G / (0.44)$

M = The appropriate multiplier as defined in the *Department's Guideline on Multipliers for Renewable Thermal Generation Units*

*Note: All terms are the cumulative as-metered values. Unless otherwise indicated, all units in MWh*

The COP<sub>OAT</sub> for each five minute interval will be determined by the use of a lookup table provided by the RTGU's original equipment manufacturer (OEM) on their letterhead. The table will show the COP of the RTGU for ambient outdoor temperatures between 5 and 50 deg. F.

The table is to be constructed as follows:

- (a) The COP<sub>OAT</sub> performance data based on conformance with AHRI 210/240 is to be used.
- (b) The COP<sub>OAT</sub> data is subdivided into 15 deg. F intervals using a linear interpolation.
- (c) The COP<sub>OAT</sub> data is extended to 60 deg. F in 15 deg. F intervals by linear interpolation.
- (d) The extension of the table below the lowest ambient test temperature as specified in the AHRI Standard 210/240 to 5 deg. F in 10 deg. F intervals cannot be done by linear interpolation but must instead be developed and submitted by the OEM along with sufficient narrative detail to permit a review

*Note: The COP<sub>OAT</sub> table will be used by the independent verifier together with the directly measured outside air temperature to compute the AECs for each operating month*

9) Metering for Large Split or VRF ASHPs

*Note: Only the components directly related to either the required APS metering or otherwise related to the terms of the AECs formula for VRF ASHPs are shown.*

**Figure 9. Metering for Large VRF ASHPs**

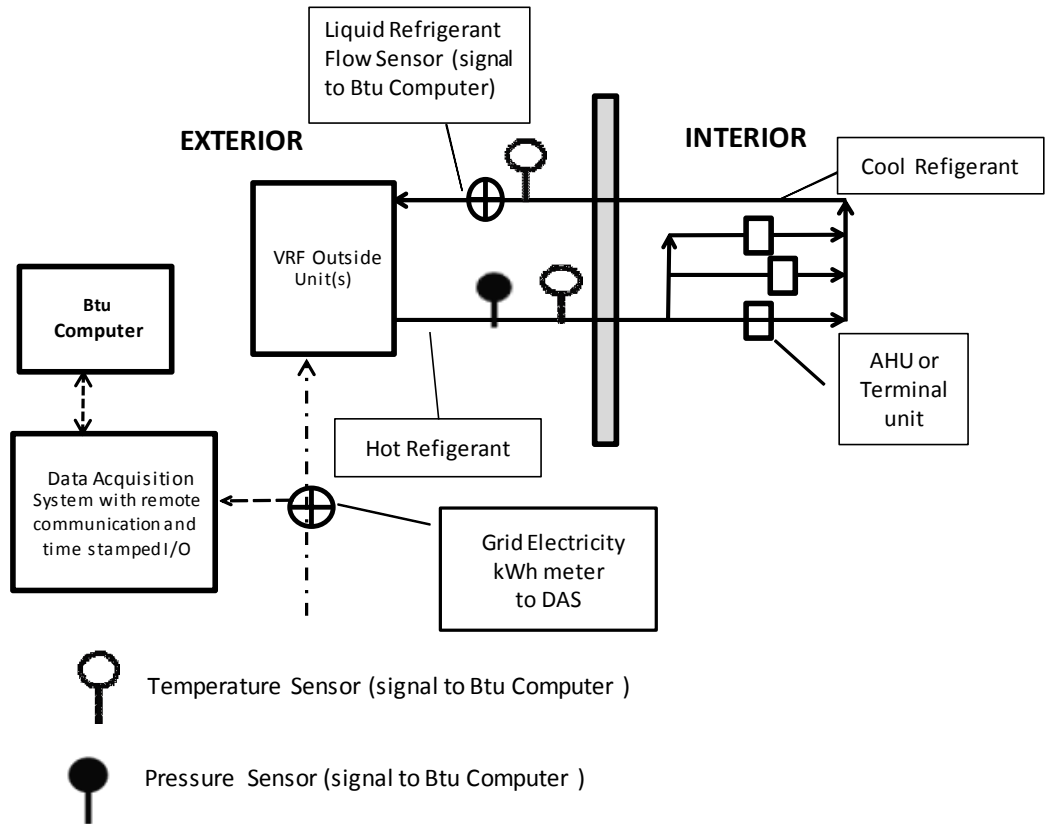

### 10) Formula for Large Split or VRF ASHPs

$$E_{\text{net,out}} = (\text{RH} - \text{G}/0.44)$$

and

$$\text{AECs} = E_{\text{net,out}} * \text{M}$$

Where:

$E_{\text{net,out}}$  = Net thermal energy output equivalent

RH = Renewable heat transferred from the ambient air to the system and is directly metered

G = Grid supplied electrical energy

Conversion of site to source nonrenewable fuel per MWh grid electricity =  $G / (0.44)$

M = The appropriate multiplier as defined in the *Department's Guideline on Multipliers for Renewable Thermal Generation Units*

*Note: All terms are the cumulative as-metered values. Unless otherwise indicated, all units in MWh*

Determination of RH:

$$\text{RH for any interval} = \text{RH}_{\text{supply}} - \text{RH}_{\text{return}}$$

Where:

$\text{RH}_{\text{supply}}$  = is the renewable thermal energy supplied from the RTGU to the useful thermal load(s)

$\text{RH}_{\text{return}}$  = is the renewable thermal energy returned from the useful thermal load the RTGU

The net renewable heat transferred (MWh) to a useful load over an interval is:

$$\text{RH}_{\text{supply}} = \text{SRF} * h_{\text{t,p}} / 3.412$$

$$\text{RH}_{\text{return}} = \text{SRF} * C_p * \text{RRT} / 3.412\text{E6 (Btu/MWh)}$$

Where:

SRF = Supply refrigerant flow (lbs/hr)

$h_{t,p}$  = Enthalpy of the refrigerant supply at its temperature and pressure (Btu/lb)

$C_p$  = Specific heat of the refrigerant (Btu/lb-deg F)

RST = Refrigerant supply temperature (°F)

RRT = Liquid Refrigerant return temperature (°F)

*Note: If the density and the  $C_p$  of the RTGU refrigerant vary significantly as a function of the refrigerant temperature, the integration of this value over time will be done by the Btu computer software engine in time steps of less than or equal to five minutes each using a look up table or function as provided by the supplier of the refrigerant.*

## **F) Intermediate and Large Ground Source Heat Pump Systems**

A typical GSHP includes, but is not limited to the following major components:

- (a) Controls
- (b) A closed refrigerant sub-system including:
  - (i) Compressor(s)
  - (ii) Evaporator(s)
  - (iii) Condenser(s)
  - (iv) Refrigerant expansion valves
  - (v) Tubing, instruments and control devices
- (c) An air side sub-system including:
  - (i) Fans
  - (ii) Louvers and dampers
  - (iii) Filters
  - (iv) Air flow related internal ducting, instruments, and control devices
- (d) A well field
- (e) A well field to heat pump circulating water loop including pump(s), piping, instruments and control devices

1) Metering for Intermediate GSHPs

**Figure 10. Metering Diagram for an Intermediate GSHP**

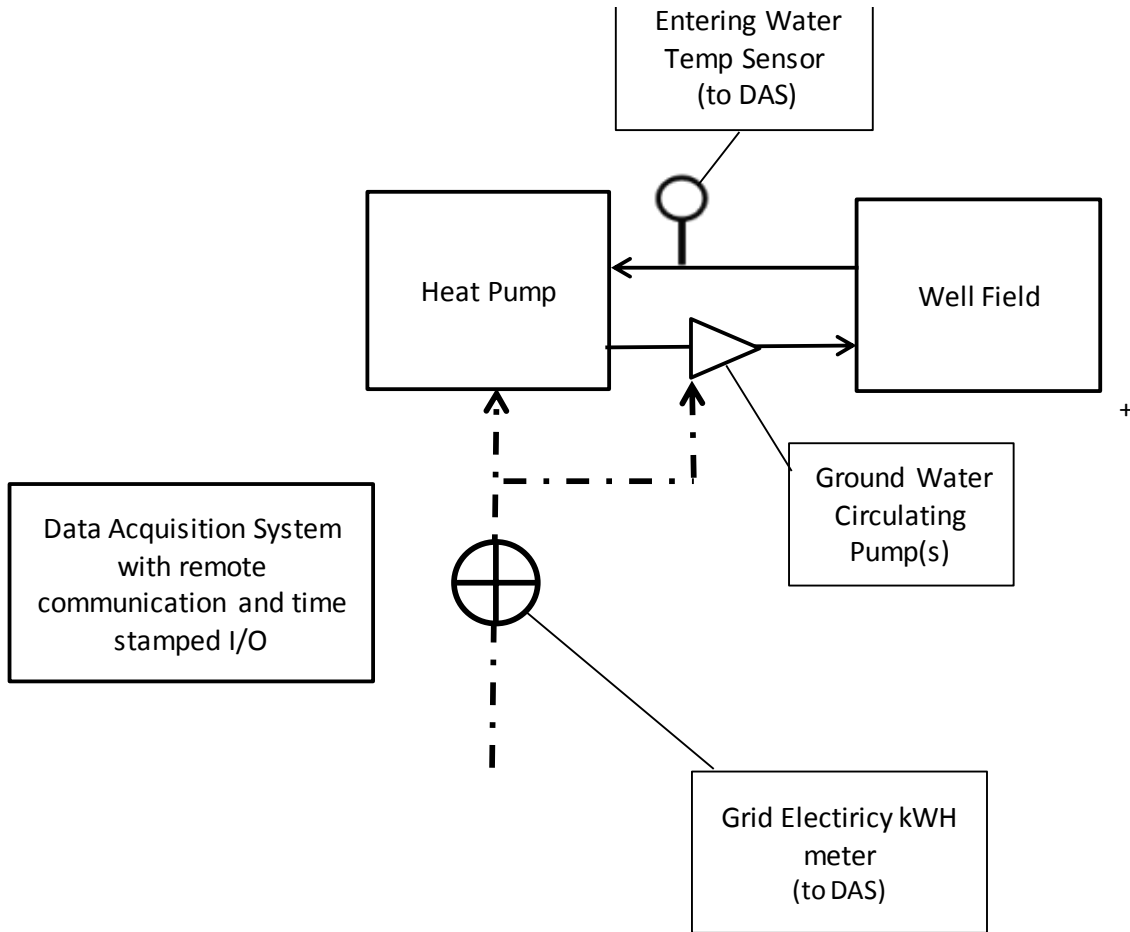

*Note: Only the components directly related to either the required APS metering or otherwise related to the terms of the AECs formula for an intermediate size GSHPs are shown.*

2) Formula for Intermediate GSHPs

$$E_{net,out} = (COP_{EWT} * G) - G/0.44$$

and

$$AECs = E_{net,out} * M$$

Where:

$E_{\text{net, out}}$  = Net thermal energy output equivalent

$\text{COP}_{\text{EWT}}$  = The book value of the coefficient of performance at the temperature of the entering water temperature as measured at the RTGU.

G = Grid supplied electrical energy

Conversion of site to source nonrenewable fuel per MWh grid electricity =  $G / (0.44)$

M = The appropriate multiplier as defined in the *Department's Guideline on Multipliers for Renewable Thermal Generation Units*

*Note: All terms are the cumulative as-metered values. Unless otherwise indicated, all units in MWh*

The  $\text{COP}_{\text{EWT}}$  for each five minute interval will be determined by the use of a lookup table provided by the RTGU's original equipment manufacturer (OEM) on their letterhead. The table will show the COP of the RTGU for each 10 degree increment in the entering water temperature between 32 and 80 deg. F.

The table is to be constructed as follows:

- (a) The AHRI rating performance data is to be used.
- (b) The AHRI rating data is subdivided into 15 deg. intervals using a linear interpolation.
- (c) The AHRI rating data is extended to 80 deg. F by linear interpolation.
- (d) Extension of the table below the lowest entering water temperature shown in the AHRI rating cannot be done by linear interpolation but must instead be developed and submitted by the OEM along with sufficient narrative detail to permit a review

*Note: The  $\text{COP}_{\text{EWT}}$  table will be used by the independent verifier together with the directly measured entering water temperature to compute the AECs for each operating month*

3) Metering for Large GSHPs

**Figure 11. Metering Diagram for a Large GSHP**

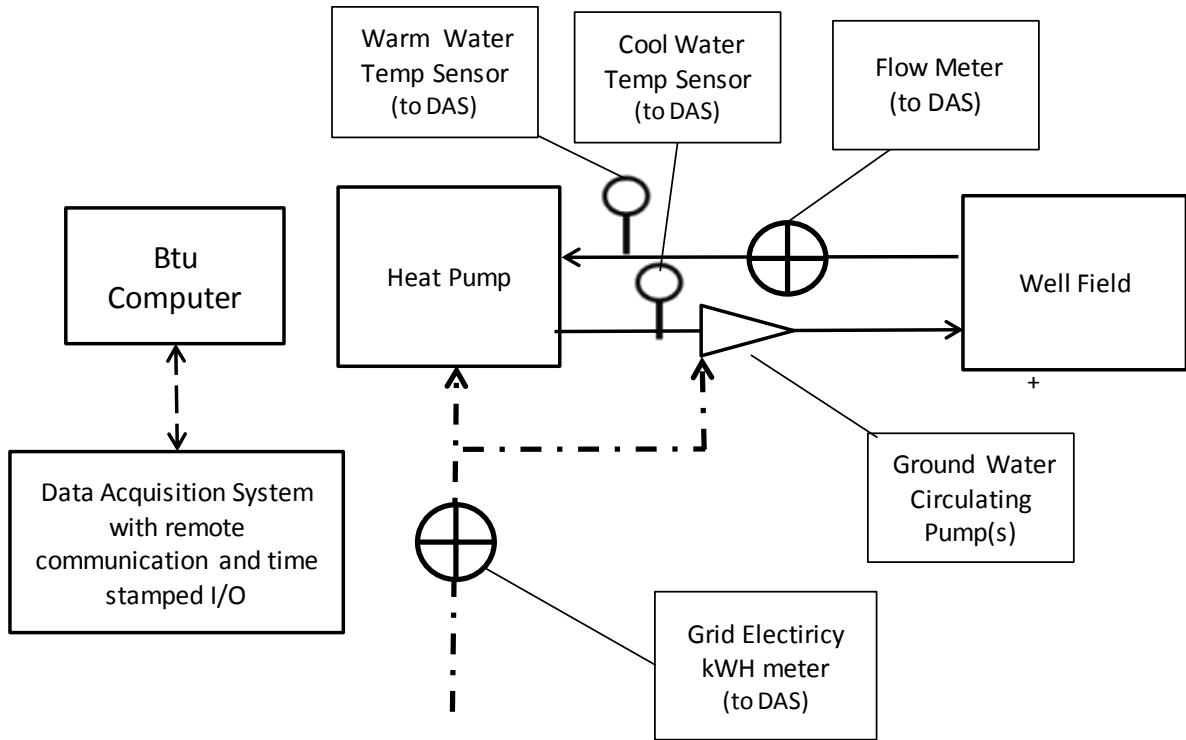

*Note: Only the components directly related to either the required APS metering or otherwise related to the terms of the AECs formula for GSHP RTGU are shown.*

4) Formula for Large GSHPs

$$E_{net,out} = RH - G/0.44$$

and

$$AECs = E_{net,out} * M$$

Where:

$E_{net,out}$  = Net thermal energy output equivalent

RH = Renewable heat transferred from the ambient air to the system and is directly metered

$M$  = The appropriate multiplier as defined in the *Department's Guideline on Multipliers for Renewable Thermal Generation Units*

*Note: All terms are the cumulative as-metered values. Unless otherwise indicated, all units in MWh*

Determination of RH:

$$RH \text{ for any interval} = RH_{\text{supply}} - RH_{\text{return}}$$

Where:

$RH_{\text{supply}}$  = is the renewable thermal energy supplied from the RTGU to the useful thermal load(s)

$RH_{\text{return}}$  = is the renewable thermal energy returned from the useful thermal load the RTGU

The rate of renewable heat transfer to a useful load:

$$= (GWSF * C_p * (GWST - GWRT) / 3.412E6 \text{ (Btu/MWh)})$$

Where:

GWSF = Ground water supply flow (lbs./hr)

$C_p$  = Specific heat of the circulating well fluid (Btu/lb-°F)

GWST = Ground water supply temperature to the GSHP (°F)

GWRT = Ground water return temperature from the GSHP (°F)

$G$  = Grid supplied electrical energy

Conversion of site to source nonrenewable fuel per MWh grid electricity =  $G / (0.44)$

*Note: All terms are the cumulative as-metered values. Unless otherwise indicated, all units in MWh*

## **G) Intermediate and Large Fired Systems**

“Fired” denotes that the RTGU converts eligible gaseous, solid or liquid fuels to useful heat either by combustion or other means.

*Notes: Fuel cells are included in this category. Any RTGU using a wood biomass fuel must comply with the added requirements as set forth in the Department's Guideline on Biomass, Biogas, and Biofuels for Eligible Renewable Thermal Generation Units.*



Firing modes for all intermediate and large fired RTGUs (all fuels must be eligible fuels)

- (a) Use of a single renewable fuel
- (b) Sequential co-firing of more than one renewable fuel
- (c) Sequential c of one or more renewable fuels and one or more non-renewable fuel
- (d) Co-firing with a blend of one or more renewable fuels
- (e) Co-firing with a blend of one or more renewable fuels with one or more non-renewable fuels

*Note: Sequential Co-firing denotes the separate combustion of fuels without blending.*

1) Fired RTGUs which are Combined Heat and Power (CHP) Systems

A RTGU which co-generates electricity and useful heat is designated as a CHP RTGU and may qualify for Massachusetts Portfolio Standard Programs and earn credits in one of two different ways:

- (a) A CHP RTGU may qualify as a Renewable Portfolio Standard (RPS) Class I generator and as an APS RTGU In this case:
  - (i) The net MWh electricity generated by the CHP RTGU earns Class I Renewable Energy Credits (RECs)
  - (ii) The net useful heat generated by the CHP RTGU earns one AEC per net MWh of useful heat transferred to a useful load
- (b) A CHP RTGU may qualify as a RPS Class I generator and as an APS CHP system per the regulations in CMR 225 16.00 that pertain to APS CHP systems and the related Guidelines. In this case:
  - (i) The net MWh of electricity generated by the CHP RTGU earns Class I RECs
  - (ii) The net MWh of electricity and the net MWh of useful heat generated by the unit earn AECs per the formula for quantifying APS CHP credits as shown in CMR 225 16.00.

This guideline is focused on the thermal output of a CHP RTGU which will earn APS Renewable Thermal AECs per option (b).

For guidance on metering and the calculation of RPS Class I RECs consult the RPS Class I Regulations 225 CMR 14.00<sup>3</sup>.

For guidance on metering and the calculation of AECs for APS CHP Systems, consult the *APS Guideline on the Eligibility and Metering of Combined Heat and Power Projects*<sup>4</sup>.

<sup>3</sup> 225 CMR 14.00 can be found at <http://www.mass.gov/courts/docs/lib/220-229cmr/225cmr14.pdf>

<sup>4</sup> The *APS Guideline on the Eligibility and Metering of Combined Heat and Power Projects* can be found at <http://www.mass.gov/eea/docs/doer/rps-aps/aps-chp-guidelines-jun14-2011.pdf>

2) Thermal Storage

A thermal storage system (TSS) is required for any biomass fueled RTGU for which the thermal output is a heat transfer fluid (including water and/or aqueous solutions). All systems over 1MMBtu/hr should have 2 gal/MBtu. Additional information regarding the thermal storage requirements can be found in the Department's *Guideline on Biomass, Biogas, and Biofuels for Eligible APS Renewable Thermal Generation Units*.

3) Metering for Intermediate Fired RTGUs, which Generate a Hot Heat Transfer Fluid and/or Steam

The major components of an intermediate, fired RTGUs include:

- (a) Primary heat generator (e.g. boiler or engine or fuel cell)
- (b) Combustion air and exhaust system
- (c) Fuel storage and delivery system
- (d) Burner system
- (e) Pollution control systems
- (f) Controls
- (g) Data Acquisition System (DAS)
- (h) Pumps, piping, fittings and heat exchangers which interconnect the RTGU to the useful thermal load
- (i) Thermal Storage System (if the system utilizes biomass)

**Figure 12. Metering Diagram for an Intermediate Fired RTUG (Both Hot HTF and Steam)**

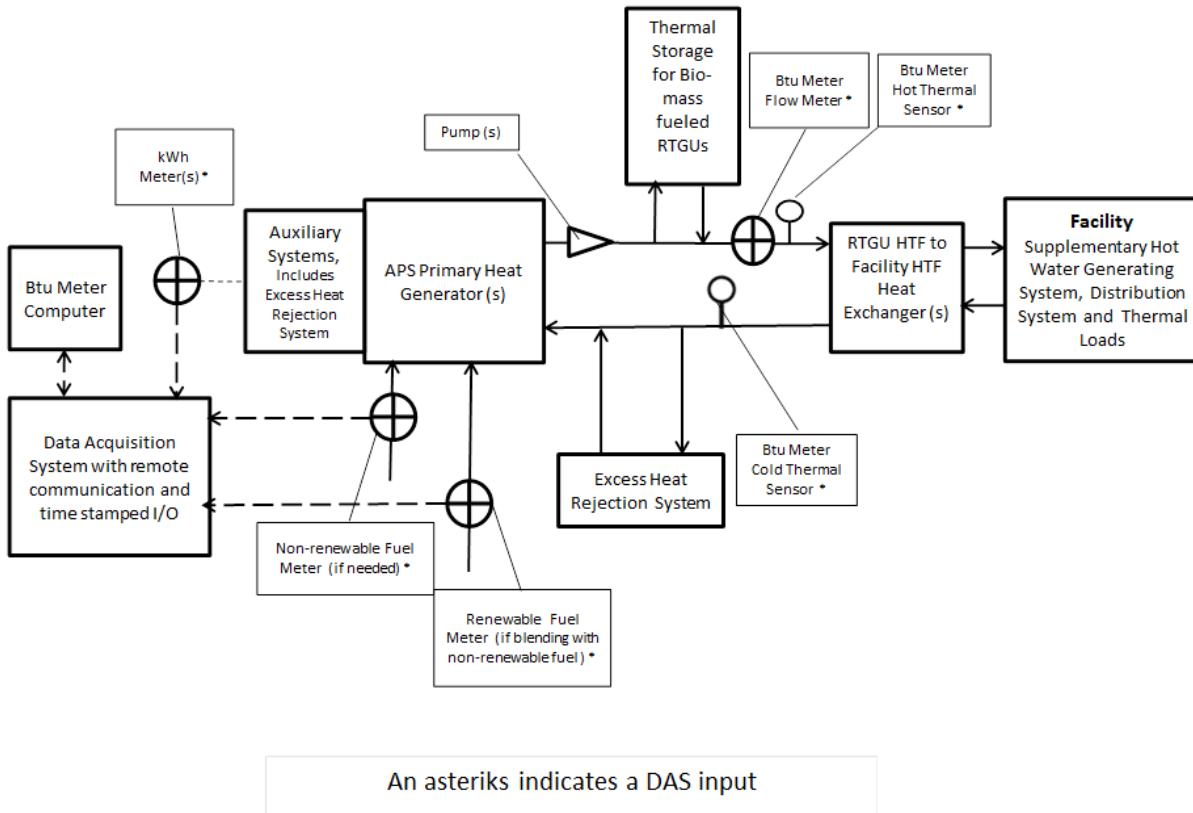

*Note: Only the components directly related to either the required APS metering or otherwise related to the terms of the AECs formula for an intermediate size fired RTGUs are shown.*

#### 4) Formula for Intermediate Fired RTGUs

$$E_{\text{net,out}} = (\text{RH} - \text{G}/0.44)$$

and

$$\text{AECs} = E_{\text{net,out}} * \text{M}$$

Where:

$E_{\text{net,out}}$  = Net thermal energy output equivalent

RH = Net Renewable heat transferred to a useful load and is not directly metered

NUH = non useful thermal heat rejected to a heat sink

G = Grid supplied electrical energy

Conversion of site to source nonrenewable fuel per MWh grid electricity =  $G / (0.44)$

M = The appropriate multiplier as defined in the *Department's Guideline on Multipliers for Renewable Thermal Generation Units*

*Note: All terms are the cumulative as-metered values. Unless otherwise indicated, all units in MWh*

*Note: For systems which includes a system that rejects heat directly generated to a heat sink (e.g. a radiator or cooling tower), the provider must either provide a method by which the heat rejected can be quantified by the independent verifier, or provide a method, such as a relay or switch, which is actuated by the operation of the heat rejection system and which transmits a signal to the data acquisition system to set to zero all AECs generated during any interval during which the heat rejection system has been running.*

#### 5) Firing Modes for Intermediate Fired RTGUs

- (a) Use of a single renewable fuel
- (b) Sequential co-firing of more than one renewable fuel
- (c) Sequential co-firing of one or more renewable fuels and one or more non-renewable fuel
- (d) Co-firing with a blend of one or more renewable fuels
- (e) Co-firing with a blend of one or more renewable fuels with one or more non-renewable fuels

*Note: Sequential Co-firing denotes the separate combustion of fuels without blending.*

6) Determination of RH for Intermediate RTGUs That Are Not CHP Systems

$$RH = RF * CRO$$

Where:

RF = Renewable Fuel

CRO = The RTGU Certified Renewable Thermal Output (MWh thermal output per MWh Renewable Fuel converted)

For all firing modes RH is obtained by means of the certified performance of the RTGU as provided by unit supplier which shows the renewable thermal output for the directly metered renewable fuel input.

If operating in mode (e) using a blend with a fixed composition, a certified performance established for the specific blend which shows the fraction of the total output for the renewable fraction of the blended fuel. If operating using a blend with a variable composition, the method of quantification will be determined on a case by case basis by the DOER.

*Note: All certifications of performance by the RTGU supplier must be submitted on the supplier's letterhead to the department for review and approval.*

7) Intermediate Fired CHP RTGUs

For all combustion modes the renewable heat is the net heat recovered from the CHP system transferred to useful load.

Quantification of RH:

The CHP RTGU electricity generated is directly metered. RH is obtained by means of the certified performance map provided by the system OEM of the CHP RTGU showing the net thermal output for each 10 kW increment of electrical output over the full range of the RTGU's generating capacity. The kW of the CHP RTGU must be recorded at intervals of less than or equal to 5 minutes.

If operating in mode (e) using a blend with a fixed composition, a certified performance established for the specific blend which shows the fraction of the total output for the renewable fraction of the blended fuel. If operating using a blend with a variable composition, the method of quantification will be determined on a case by case basis by the DOER.

8) Large Fired RTGUs which Generate a Hot Heat Transfer Fluid

Major Components of a large, fired RTGU which generates hot heat transfer fluid include:

- (a) Primary heat generator (e.g. boiler or engine or fuel cell)
- (b) Combustion air and exhaust system
- (c) Fuel storage and delivery system
- (d) Burner system
- (e) Pollution control systems
- (f) Controls
- (g) Data acquisition system (DAS)
- (h) Pumps, piping, fittings and heat exchangers which interconnect the RTGU to the useful thermal load

9) Metering for Large Fired RTGUs which Generate a Hot Heat Transfer Fluid

The following guidelines are based on a generic basic configuration as shown in Figure 13.

The Department will evaluate metering plans and submittals based on alternative configurations on a case-by-case basis.

**Figure 13. Metering Diagram for a Large Fired RTUG which Generates a Hot Heat Transfer Fluid**

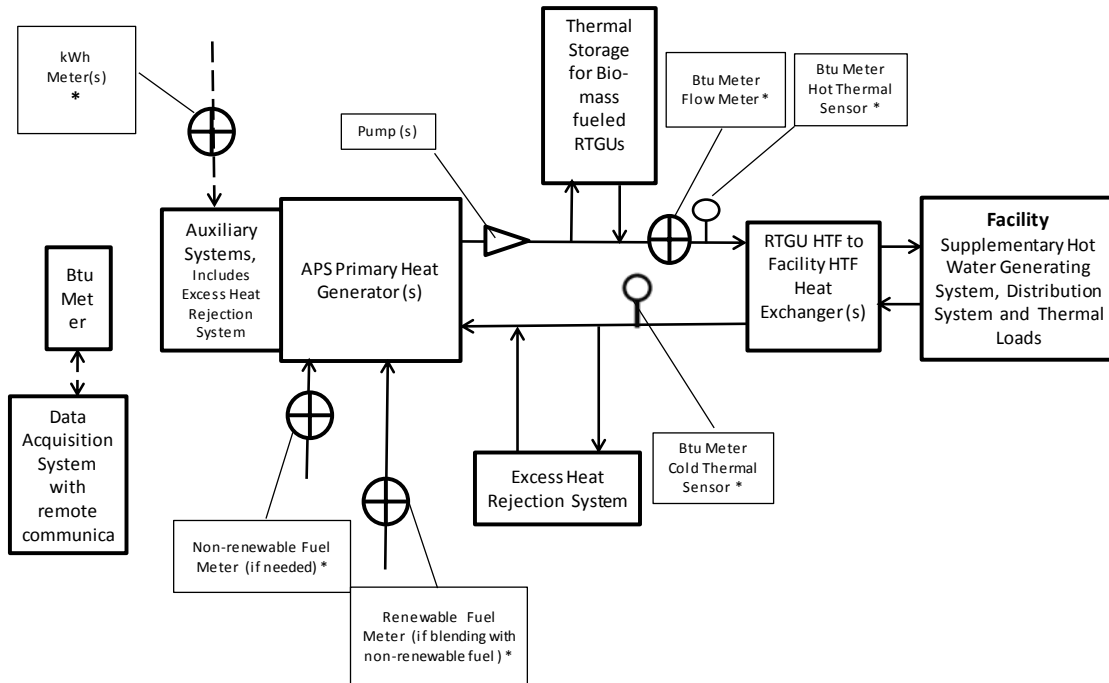

An asteriks indicates a DAS input

*Note: Only the components directly related to either the required APS metering or otherwise related to the terms of the AECs formula for a large fired RTUG which Generates a Hot Heat Transfer Fluid are shown.*

10) Formulae for a Large, RTGU Generating a Hot Heat Transfer Fluid

$$E_{net,out} = (RH - NUH - P_t - G/0.44)$$

and

$$AECs = E_{net,out} * M$$

Where:

RH = Renewable heat transferred to a useful load and is directly metered

NUH = Non useful thermal heat rejected to a heat sink

G = Grid supplied electrical energy

Conversion of site to source nonrenewable fuel per MWh grid electricity =  $G / (0.44)$

Pt = Parasitic thermal energy

M = The appropriate multiplier as defined in the *Department's Guideline on Multipliers for Renewable Thermal Generation Units*

*Note: All terms are the cumulative as-metered values. Unless otherwise indicated, all units in MWh*

*Note: For systems which includes a system that rejects heat directly generated to a heat sink (e.g. a radiator or cooling tower), the provider must either provide a method by which the heat rejected can be quantified or provide a method, such as a relay or switch which is actuated by the operation of the heat rejection system and will transmits a signal to the data acquisition system to set to zero all AECs generated during any interval during which the heat rejection system has been running. For a CHP RTGU, G does not include any electricity supplied to auxiliary systems by the CHP generator(s)*

### 11) Firing Modes

- (a) Use of a single renewable fuel
- (b) Sequential co-firing of more than one renewable fuel
- (c) Sequential co-firing of one or more renewable fuels and one or more non-renewable fuel
- (d) Co-firing with a blend of one or more renewable fuels
- (e) Co-firing with a blend of one or more renewable fuels with one or more non-renewable fuels

*Note: Sequential Co-firing denotes the separate combustion of fuels without blending.*

Determination of RH:

RH for Firing Modes (a), (b), (c), (d):

$$\text{RH for any interval} = \text{RH}_{\text{supply}} - \text{RH}_{\text{return}}$$

Where:

$\text{RH}_{\text{supply}}$  = is the renewable thermal energy supplied from the RTGU to the useful thermal load(s)

$\text{RH}_{\text{return}}$  = is the renewable thermal energy returned from the useful thermal load the RTGU

The rate of renewable heat transfer to a useful load



$$= \text{HTFF} * \text{Cp HTF} * (\text{HTFST} - \text{HTFRT}) / 3.412\text{E}6 \text{ (Btu/MWh)}$$

RH for any interval operating in Mode (e) =

$$= (\text{RF} / (\text{RF} + \text{NRF}) * (\text{RH}_{\text{supply}} - \text{RH}_{\text{return}})$$

The rate of renewable heat transfer to a useful load is

$$= (\text{RF} / (\text{RF} + \text{NRF}) * \text{HTFF} * \text{Cp HTF} * (\text{HTFST} - \text{HTFRT}))$$

Where:

HTFF = Heat transfer fluid flow (lbs./hr)

RF = The metered renewable fuel

NRF = Non-renewable fuel

Cp HTF = The constant pressure specific heat of the HTF (MWh/lb-°F)

HTST= HTF supply temperature (°F)

HTRT= HTF return temperature (°F)

RF = Consumption of all renewable fuel (MWh)

NRF = Consumption of all non-renewable fuel (MWh)

## 12) Large Fired RTGU which Generate Steam

The major components of a large fired RTGU that generates steam are:

- (a) A primary heat generator (e.g. an internal combustion engine, combustion turbine, or boiler)
- (b) A fired heat recovery steam generator (HRSG)
- (c) A Deaerator / Feedwater Heater(s)
- (d) Pumps, piping, fittings and heat exchangers which connect the primary heat generator with the facility thermal distribution system and allow the transfer of thermal energy from the generation system to the facility thermal loads.
- (e) Condensate return system
- (f) Feedwater system
- (g) Make up water system
- (h) A blowdown heat recovery system

- (i) Pollution controls
- (j) Auxiliary Systems (e.g. heat rejection system (e.g. radiators or cooling towers ), feedwater pumps, fans, blowers, fuel gas compressors)
- (k) System controls
- (l) Data acquisition and plant historian systems

### 13) General Metering Requirements for Large RTGUs Generating Steam

The following guidelines are based on a generic basic configuration as shown in the following guidelines are based on a generic basic configuration as shown in Figure 14.

The Department will evaluate metering plans and submittals based on alternative configurations on a case-by-case basis.

The Department will evaluate metering plans and submittals based on alternative configurations on a case-by-case basis

- (a) Btu and kWh meters as shown in Figure 14.
- (b) Fuel metering is required when a renewable fuel will be blended with a non-renewable fuel
- (c) Data acquisition systems (DAS) for recording, storing and transmitting of time stamped kWh, Btu, and fuel meter data.

*Note: Any RTGU using a woody biomass fuel must comply with the added requirements as set forth in the APS Guideline on Biomass, Biogas, and Biofuels for Eligible Renewable Thermal Generation Units.*

**Figure 14. Simplified Schematic Diagram of a Generic Large RTGU Generating Steam**

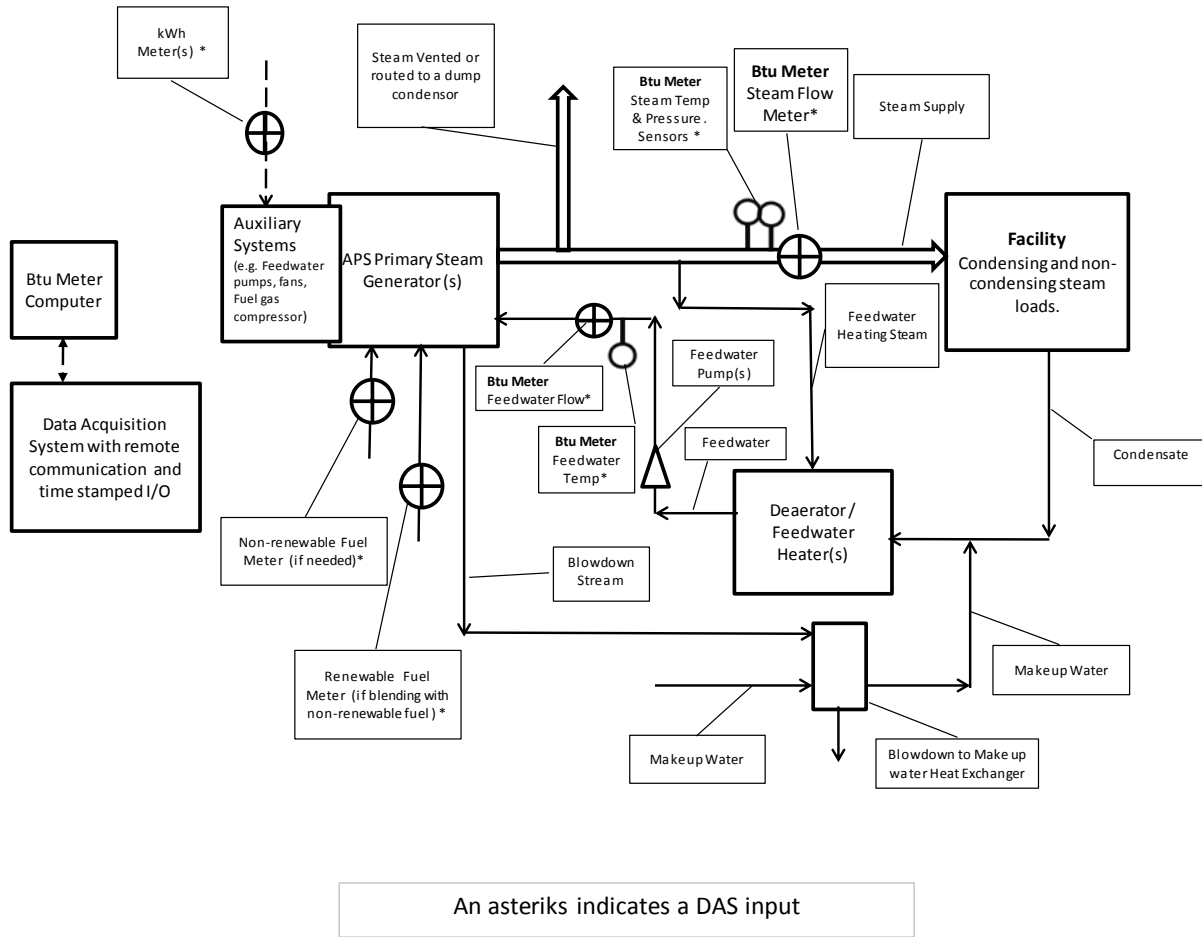

14) Formula for Large RTGUs Generating Steam

$$E_{net, out} = (RH - NUH - P_t - G/0.44)$$

and

$$AECs = E_{net, out} * M$$

Where:

$E_{net, out}$  = Net thermal energy output equivalent

RH = The renewable thermal energy transferred to a useful load

G = Grid supplied electrical energy

Conversion of site to source nonrenewable fuel per MWh grid electricity =  $G / (0.44)$

NUH = non useful renewable thermal heat

Pt= Parasitic thermal energy

M = The appropriate multiplier as defined in the *Department's Guideline on Multipliers for Renewable Thermal Generation Units*

*Note: All terms are the cumulative as-metered values. Unless otherwise indicated, all units in MWh*

- (a) For systems which includes a system that rejects steam to a heat sink (e.g. a, cooling tower or blow down drain), the non-useful energy must either be metered or accounted for by calculation. The determination of whether a meter is required will be determined by the Department on a case by case basis/
- (b) Thermal energy in a boiler blowdown stream that is recovered and transferred to a useful load (e.g. heating make up or feedwater) is considered to be thermal energy transferred to a useful load and is to be included in the RH term.
- (c) The ideal steam and condensate return distribution system would require no makeup water, related feed water heating and minimal deaerating. However, this ideal typically cannot be achieved. The Department considers that for a well-designed and maintained closed steam distribution system, the amount of makeup water should not be more than 10% of the amount of steam generated. For this reason, for a closed system, the steam heating of the feedwater is a non-useful load and which is accounted for by basing the useful heat transferred on the difference between the enthalpy of the steam generated minus the enthalpy of the feedwater supplied. Refer to The following guidelines are based on a generic basic configuration as shown in Figure 14.
- (d) The Department will evaluate metering plans and submittals based on alternative configurations on a case-by-case basis.
- (e) Figure 14 for the placement of the Btu meter on the feedwater return after the deaerator. Many steam generating and distribution systems are not closed in that there are locations where, by design, steam is released and are not returned as condensate. Examples of this are sparging (the direct injection of live steam into a process for the purpose of heating) or the use of steam as a reactant in a process.
- (f) Whenever the pounds of makeup water are greater than 10% of the pounds of steam generated due to the reasons listed above or others as are approved by the Department on a case-by-case basis, the temperature to be used for the feedwater supply will be the temperature of the combined flows of the condensate return and the makeup water.
- (g) For a CHP RTGU, G does not include any electricity supplied to auxiliary systems by the CHP generator(s)
- (h) Parasitic thermal energy consumption in RTGU steam generators is most often associated with motive steam to drive auxiliary systems e.g. feedwater pumps or compressors, absorption chillers used to pre-cool gas turbine inlet air, and feedwater heating.
- (i) All efforts should be made to locate system Btu meters such that the consumption of thermal parasitic thermal energy is netted out. In the event that this cannot be accomplished the parasitic thermal energy of any auxiliary component with a demand above a To Be Determined

value during nominal operating conditions will require a separate Btu meter and the energy required to operate them is not metered or included in the determination of the AECs.

#### Determination of RH

For Modes a, b, c, d:

$$RH \text{ for any interval} = RH_{\text{supply}} - RH_{\text{return}}$$

Where:

$RH_{\text{supply}}$  = is the renewable thermal energy supplied from the RTGU to the useful thermal load(s)

$RH_{\text{return}}$  = is the renewable thermal energy returned from the useful thermal load the RTGU

The rate of renewable heat transfer to a useful load

$$= (SF * hS - FW * hFW) / 3.412E6 \text{ (Btu/MWh)}$$

For Mode (e):

RH for any interval

$$= (RF / (RF + NRF)) * (RH_{\text{supply}} - RH_{\text{return}})$$

The rate of renewable heat transfer to a useful load

$$= (RF / (RF + NRF)) * (SF * hS - FW * hFW) / 3.412E6 \text{ (Btu/MWh)}$$

Where:

SF = Steam generated (lbs.)

FW = Total feedwater flow (lbs.)

hS = Supply Steam enthalpy (Btu/lb)

hFW = Feed water enthalpy (Btu/lb)

RF = The metered renewable fuel (Btu)

NRF = Non-renewable fuel (Btu)

## **H) Compost Vapor Heat Recovery RTGUs**

### 1) Major Components

The major components of a Compost Vapor Heat Recovery RTGU are:

- (a) Vapor to water heat exchanger(s)
- (b) Pumps, piping, fittings which interconnect connect the RTGU with the facility thermal distribution system and allow the transfer of thermal energy from the generation system to the facility thermal loads.
- (c) Condensate return system
- (d) Systems to reject excess heat
- (e) System controls
- (f) Data acquisition and plant historian systems

2) Metering for Compost Vapor Heat Recovery RTGUs

**Figure 15. Simplified Schematic Diagram of a Compost Vapor Heat Recovery RTGU**

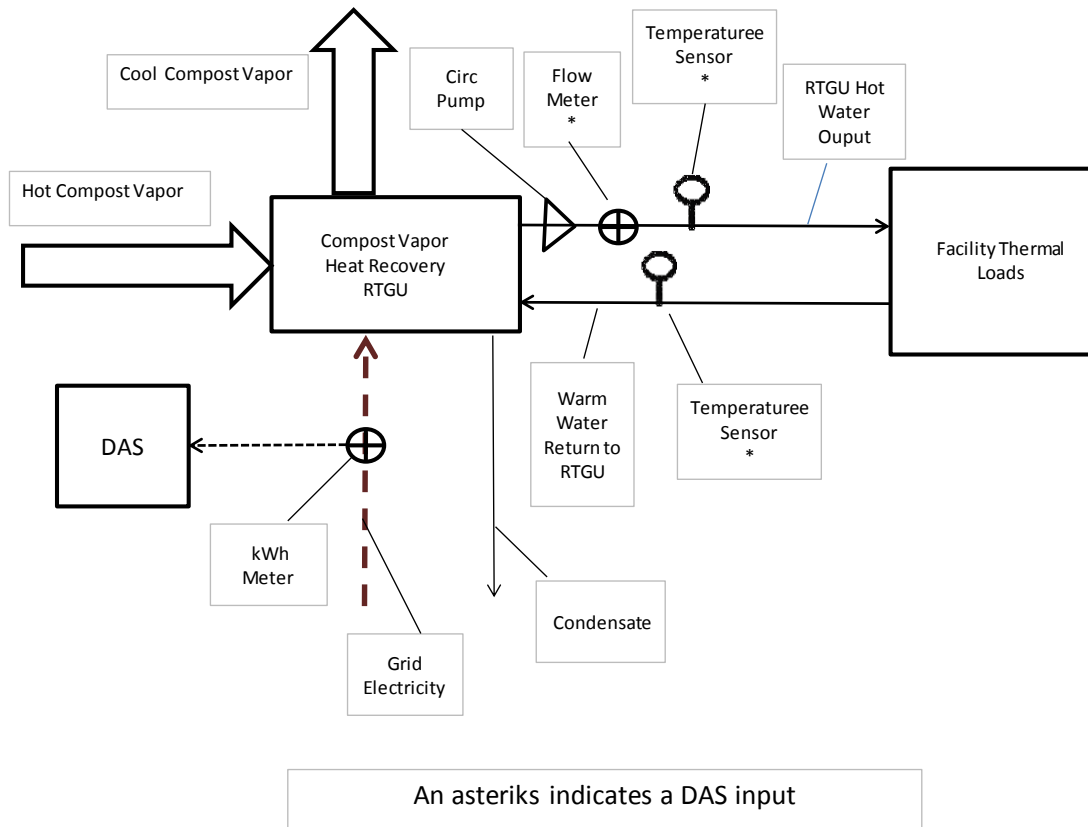

### 3) Formula for Compost Vapor Recovery RTGUs

$$E_{\text{net, out}} = (RH - NUH - G/0.44)$$

and

$$AECs = E_{\text{net, out}} * M$$

Where:

$E_{\text{net, out}}$  = Net thermal energy output equivalent

RH = Renewable heat transferred to the useful loads

NUH = Any heat generated by the RTGU that is transferred to a non-useful load such as heat rejected by an over temperature protection system.

M = The appropriate multiplier as defined in the *Department's Guideline on Multipliers for Renewable Thermal Generation Units*

Determination of RH:

$$RH \text{ for any interval} = RH_{\text{supply}} - RH_{\text{return}}$$

Where:

$RH_{\text{supply}}$  = is the renewable thermal energy supplied from the RTGU to the useful thermal load(s)

$RH_{\text{return}}$  = is the renewable thermal energy returned from the useful thermal load the RTGU

The renewable heat transfer to a useful load over an interval:

$$= (GWSF * C_p * (CWST - CWRT) / 3.412E6 \text{ (Btu/MWh)})$$

Where:

GWSF = Ground water supply flow (lbs)

$C_p$  = Specific heat of the circulating loop fluid (Btu/lb-°F)

CWST = Circulating hot water supply temperature to the useful load (°F)



CWRT = Circulating water return temperature from the useful load (°F)

G = Grid supplied electrical energy

Conversion of site to source nonrenewable fuel per MWh grid electricity=  $G / (0.44)$

**4) Miscellaneous**

The Department may permit an exception from any provision of this Guideline for good cause, so long as the exception is consistent with the requirements set out in G.L. c. 25A, § 11F ½ and regulations promulgated thereunder.