



October 2014

SPENT NUCLEAR FUEL MANAGEMENT

Outreach Needed to Help Gain Public Acceptance for Federal Activities That Address Liability

GAO Highlights

Highlights of [GAO-15-141](#), a report to congressional requesters

Why GAO Did This Study

DOE is responsible for disposing of commercial spent nuclear fuel. DOE entered into contracts with owners and generators of spent nuclear fuel to begin disposing of it beginning in 1998, with plans for disposal in a national repository. DOE, however, was unable to meet the 1998 date and, as a result of lawsuits, the federal government has paid out about \$3.7 billion for storage costs. DOE proposed a new strategy in January 2013 to build consolidated interim storage facilities—starting operations in 2021 and 2025.

GAO was asked to review issues related to DOE's strategy for managing spent nuclear fuel. This report (1) describes the expected rate of spent nuclear fuel accumulation in wet and dry storage, (2) identifies the basis of federal liability for spent nuclear fuel management to date and of DOE's estimate of future liabilities, and (3) assesses challenges, if any, that experts and stakeholders have identified to the federal government's ability to meet DOE's time frames for managing spent nuclear fuel at consolidated interim storage facilities and potential ways for DOE to mitigate the challenges. GAO reviewed documents from DOE and other agencies, and interviewed experts and stakeholders from industry, federal and state governments, interest groups, and independent entities.

What GAO Recommends

DOE should implement a coordinated outreach strategy to better inform the public about federal spent nuclear fuel management issues. DOE generally agreed with the findings and recommendation in the report.

View [GAO-15-141](#). For more information, contact Frank Rusco at (202) 512-3841 or ruscof@gao.gov.

October 2014

SPENT NUCLEAR FUEL MANAGEMENT

Outreach Needed to Help Gain Public Acceptance for Federal Activities That Address Liability

What GAO Found

Spent nuclear fuel—the used fuel removed from nuclear power reactors—is expected to accumulate at an average rate of about 2,200 metric tons per year in the United States. This spent nuclear fuel is mostly stored wet, submerged in pools of water. However, since pools have been reaching their capacities, owners and generators of spent nuclear fuel (typically utilities and reactor operators) have been transferring it to canisters that are placed in casks on concrete pads for dry storage—which is an expensive and time-consuming process. When operating reactors' licenses begin to expire in the 2030s, the rate of spent nuclear fuel accumulation is expected to decrease, but the amount in dry storage will increase as the pools are closed and all spent nuclear fuel is transferred to dry storage. By 2067, the currently operating reactors are expected to have generated about 139,000 metric tons of spent nuclear fuel, nearly all of which is expected to be transferred to dry storage.

Federal liability for managing spent nuclear fuel has been based on costs that owners and generators of this fuel have paid because the Department of Energy (DOE) has not met its contractual obligation to dispose of spent nuclear fuel. DOE's estimate of future federal liability is based on how long DOE expects the federal government to continue to pay the costs for managing spent nuclear fuel to plant owners and generators. Generally, the damages paid—mostly for the costs of transferring spent nuclear fuel from wet to dry storage—have been for costs that owners and generators would not have incurred if DOE had begun disposing of the spent nuclear fuel. DOE's most recent estimate of future liability—\$21.4 billion through 2071—assumes that DOE will begin taking title to and possession of spent nuclear fuel in 2021 and complete the process in 2071, thereby ending the federal liability. DOE has extended the expected date that the last of the spent nuclear fuel will be picked up several times, and each extension has added to the future federal liability.

Spent nuclear fuel management experts and stakeholders GAO spoke with identified several legislative, regulatory, technical, and societal challenges to meeting DOE's time frames for managing spent nuclear fuel at interim storage facilities. Although DOE has begun to take actions to address some of these challenges, officials noted that the department's strategy cannot be fully implemented until Congress provides direction on a new path forward. However, experts and stakeholders believe that one key challenge—building and sustaining public acceptance of how to manage spent nuclear fuel—will need to be addressed irrespective of which path Congress agrees to take. In this context, they suggested the need for a coordinated public outreach strategy regarding spent nuclear fuel management issues, including perceived risks and benefits, which would be consistent with the Administration's directive to be more transparent and collaborative. DOE officials stated they currently do not have such a strategy. Without a better understanding of spent nuclear fuel management issues, the public may be unlikely to support any policy decisions about managing spent nuclear fuel.

Contents

Letter		1
	Background	4
	About 2,200 Metric Tons of Spent Nuclear Fuel Is Expected to Accumulate Annually, Mostly in Wet Storage, but This Pace Is Expected to Change as Reactors Shut Down	11
	Federal Liability for Spent Nuclear Fuel Management Is Based on Costs Incurred Because DOE Has Not Met Contract Obligations	16
	Experts and Stakeholders Identified Challenges to and Suggestions for Managing Spent Nuclear Fuel at Interim Storage Facilities within DOE's Time Frames	19
	Conclusions	36
	Recommendation for Executive Action	37
	Agency Comments	37
Appendix I	Objectives, Scope, and Methodology	39
Appendix II	Spent Nuclear Fuel Experts and Stakeholders We Interviewed	43
Appendix III	Commercial Spent Nuclear Fuel Stored in Wet, Dry, and Shutdown Storage Sites (Text for Interactive Figure 5)	46
Appendix IV	Additional Information on the Spent Nuclear Fuel Settlement Agreements	49
Appendix V	Process and Costs of Transferring Spent Nuclear Fuel from Wet to Dry Storage (Text for Interactive Figure 7)	52
Appendix VI	Comments from the Department of Energy	53
Appendix VII	GAO Contact and Staff Acknowledgments	55

Tables

Table 1: Typical Reactor Characteristics, Canister Storage Capacity	17
Table 2: Typical Costs Associated with Transferring Spent Nuclear Fuel in Canisters from Wet to Dry Storage	17

Figures

Figure 1: Nuclear Fuel Pellet and Fuel Rod Assembly for a Commercial Nuclear Power Reactor	6
Figure 2: Spent Nuclear Fuel in Wet Pool Storage	7
Figure 3: Dry Cask Storage System for Spent Nuclear Fuel	9
Figure 4: Spent Nuclear Fuel in Dry Storage	10
Figure 5: Commercial Spent Nuclear Fuel Stored in Wet, Dry, and Shutdown Storage Sites	13
Figure 6: Estimated Amount of Accumulation of Spent Nuclear Fuel in Wet and Dry Storage through 2067	15
Figure 7: Process and Costs of Transferring Spent Nuclear Fuel from Wet to Dry Storage	18
Figure 8: Four Major Types of Challenges Identified By Experts and Stakeholders on Federal Efforts to Manage Spent Nuclear Fuel at Consolidated Interim Storage Facilities	20

Abbreviations

DOE Department of Energy
NRC Nuclear Regulatory Commission
NWPA Nuclear Waste Policy Act of 1982

This is a work of the U.S. government and is not subject to copyright protection in the United States. The published product may be reproduced and distributed in its entirety without further permission from GAO. However, because this work may contain copyrighted images or other material, permission from the copyright holder may be necessary if you wish to reproduce this material separately.



October 9, 2014

The Honorable Fred Upton
Chairman
Committee on Energy and Commerce
House of Representatives

The Honorable John Shimkus
Chairman
Subcommittee on Environment and the Economy
Committee on Energy and Commerce
House of Representatives

Spent nuclear fuel—used nuclear fuel that has been removed from the reactor core of a nuclear power plant¹—is an extremely harmful substance if not managed properly. Without protective shielding, its intense radioactivity can kill a person who is directly exposed to it or cause long-term health hazards, such as cancer. In addition, if not managed properly, or if it were released by a natural disaster or an act of terrorism, it could contaminate the environment with radiation. The nation’s inventory of spent nuclear fuel from commercial nuclear power reactors is stored at 75 sites in 33 states, generally where it was generated. The spent nuclear fuel is stored either wet in pools of water or dry in storage systems that typically consist of stainless steel canisters within protective casks. Over the past several decades, the inventory of commercial spent nuclear fuel in storage in the United States has grown to about 72,000 metric tons.

To address the growing inventory, Congress made disposal of spent nuclear fuel a federal responsibility with the passage of the Nuclear

¹Spent (or used) nuclear fuel can no longer efficiently generate power in a nuclear reactor. However, it is potentially a resource because it can be reprocessed to separate out uranium and plutonium to be used again as fuel in a reactor. Reprocessing, however, still results in high-level radioactive waste that requires disposal, and the United States does not currently reprocess spent nuclear fuel from commercial nuclear power reactors. The federal government generates spent nuclear fuel from power, research, and navy shipboard reactors. The U.S. Nuclear Regulatory Commission considers spent nuclear fuel that is accepted for disposal to be high-level radioactive waste. High-level radioactive waste also includes byproducts of weapons production and other defense-related activities generated from reprocessing spent nuclear fuel. The scope of this review only includes commercial spent nuclear fuel.

Waste Policy Act of 1982 (NWPAs), which directed the Department of Energy (DOE) to investigate sites for a permanent repository.² The act also authorized DOE to enter into contracts with owners and generators of commercial spent nuclear fuel—typically utilities and reactor operators—to begin taking title to (legal ownership) spent nuclear fuel following commencement of a repository and disposing of spent nuclear fuel beginning no later than January 31, 1998. In 1987, Congress amended the act to direct DOE to focus its efforts only on a site at Yucca Mountain, Nevada, about 100 miles northwest of Las Vegas. DOE did not begin disposing of spent nuclear fuel by 1998 because of state and local opposition to a repository in Nevada, technical complexities, and funding uncertainties, among other reasons.³

Since 1998, owners and generators of spent nuclear fuel have sued DOE primarily in the U.S. Court of Federal Claims for failing to meet its obligations under the contracts that DOE had entered into with them. The Department of Justice reported that as of March 2014, 90 such lawsuits had been filed. As of the end of fiscal year 2013, the federal government had reimbursed owners and generators about \$3.7 billion in connection with such lawsuits.⁴ The reimbursements come from the U.S. Department of Treasury’s judgment fund,⁵ which is financed by U.S. taxpayers. DOE estimates that future federal liability for litigation related to storing spent nuclear fuel will amount to \$21.4 billion through 2071.

In 2008, DOE submitted a license application for a repository at Yucca Mountain to the Nuclear Regulatory Commission (NRC), which is

²Pub. L. 97-425 §§ 112, 113. NWPAs also addressed disposal of high-level radioactive waste other than spent nuclear fuel.

³See GAO, *Commercial Nuclear Waste: Effects of a Termination of the Yucca Mountain Repository Program and Lessons Learned*, [GAO-11-229](#) (Washington, D.C.: Apr. 8, 2011).

⁴In addition to the \$3.7 billion reimbursed to owners and generators through fiscal year 2013, the Department of Justice, which defends DOE in the lawsuits, has expended approximately \$219.5 million in defense-related costs, as of December 31, 2013. Industry officials said that, for proprietary reasons, they could not provide a total for their litigation costs but that they are also incurring similar expenses. While the courts have not ordered the federal government to reimburse utilities for attorneys’ fees, the Court of Federal Claims generally has awarded court costs to utility plaintiffs.

⁵The fund is a permanent, indefinite appropriation for the payment of judgments against the United States.

responsible for regulating storage, transportation, and disposal of spent nuclear fuel from commercial nuclear power reactors. Then, in a change of policy in 2009, the Secretary of Energy said that a repository at Yucca Mountain was not a workable option, and in 2010, DOE terminated its efforts to license a repository there. In 2010, DOE chartered the Blue Ribbon Commission on America's Nuclear Future to recommend a plan for management and disposal of spent nuclear fuel. In January 2012, the Blue Ribbon Commission recommended that Congress create and fund a new organization dedicated solely to managing spent nuclear fuel.⁶ The commission also recommended development of a consent-based approach to locating or establishing (or "siting") future spent nuclear fuel management facilities, among other things. In January 2013, DOE issued a strategy for managing spent nuclear fuel in response to the commission's recommendations.⁷ The strategy calls for the federal government to begin accepting spent nuclear fuel for management at a pilot interim storage facility by 2021 and at a larger consolidated interim storage facility by 2025, among other things. According to the strategy, it represents "an initial basis for discussions among the Administration, Congress and other stakeholders on a sustainable path forward for disposal" of spent nuclear fuel and other types of high-level radioactive waste. According to DOE's strategy, beginning operations at the pilot and larger interim storage facilities in 2021 and 2025, respectively, will allow the federal government to accept enough spent nuclear fuel to limit expected federal liabilities to DOE's fiscal year 2013 liability estimate of \$21.4 billion. Delays in meeting the strategy's milestones for interim storage might result in additional liabilities.

In light of the billions of dollars in liabilities being paid by taxpayers because the federal government has not begun disposing of spent nuclear fuel as it agreed to do, you asked us to review issues related to DOE's spent nuclear fuel strategy and the federal government's liabilities. This report (1) describes the expected rate of spent nuclear fuel accumulation in wet and dry storage, (2) identifies the basis of federal liability for spent nuclear fuel management to date and of DOE's estimate

⁶Blue Ribbon Commission on America's Nuclear Future, *Report to the Secretary of Energy*, (Washington, D.C.: Jan. 26, 2012). The Blue Ribbon Commission's recommended plan was to cover spent nuclear fuel and other high-level waste.

⁷DOE, *Strategy for the Management and Disposal of Used Nuclear Fuel and High-Level Radioactive Waste*, (Washington, D.C.: January 2013).

of future liabilities, and (3) assesses challenges, if any, that experts and stakeholders have identified to the federal government's ability to meet DOE's time frames for managing spent nuclear fuel at consolidated interim storage facilities and potential ways for DOE to mitigate the challenges.

To answer these objectives, we reviewed documents and interviewed officials from DOE and NRC regarding their regulatory roles related to spent nuclear fuel management. We also consulted with Department of Justice officials regarding their role in defending the government in the owners' and generators' lawsuits. In addition, we obtained input from experts and stakeholders in spent nuclear fuel management. Specifically, to describe the expected rate of spent nuclear fuel accumulation in wet and dry storage, we obtained data from the Nuclear Energy Institute, an industry policy umbrella organization. This information contains the amounts of spent nuclear fuel currently in wet and dry storage, and projected amounts of spent nuclear fuel to be added to the current wet and dry storage inventory as spent nuclear fuel is removed from reactors until they shut down. To identify the basis of federal liability for spent nuclear fuel management to date and of DOE's estimate of future liabilities, we reviewed DOE documents and interviewed DOE officials. To assess the challenges, if any, that experts and stakeholders have identified to the federal government's ability to meet DOE's time frames for managing spent nuclear fuel at consolidated interim storage facilities and potential ways for DOE to mitigate these challenges, we identified individuals with spent nuclear fuel management experience and expertise. We obtained input from these experts and stakeholders by interviewing them and reviewing documents prepared by the organizations with which they are affiliated. Appendix I presents our scope and methodology in more detail and appendix II lists the experts and stakeholders with whom we consulted.

We conducted this performance audit from November 2013 to October 2014, in accordance with generally accepted government auditing standards. Those standards require that we plan and perform the audit to obtain sufficient, appropriate evidence to provide a reasonable basis for our findings and conclusions based on our audit objectives. We believe that the evidence obtained provides a reasonable basis for our findings and conclusions based on our audit objectives.

Background

Fuel for commercial nuclear power reactors is typically made from low enriched uranium fashioned into thumbnail-size ceramic pellets of

uranium dioxide. These pellets are fitted into 12- to 15-foot hollow rods, referred to as cladding, made of a zirconium alloy. The rods are then bound together into a larger assembly. A typical reactor holds about 100 metric tons of fuel when operating—generally from 200 to 800 fuel assemblies. The uranium in the assemblies undergoes fission—a process of splitting atoms into fragments and neutrons that then bombard other atoms—resulting in additional fission reactions and a sustainable chain reaction that creates an enormous amount of heat and radioactivity in the form of radioisotopes, or radioactive substances. The heat is used to generate steam to turn a turbine, which generates electricity. The radioisotopes produced in a reactor can remain hazardous from a few days to many thousands of years; these radioisotopes remain in the fuel assemblies and as components of the resulting spent nuclear fuel. Figure 1 shows what a fuel pellet for a commercial nuclear reactor and a fuel rod in an assembly look like.

Figure 1: Nuclear Fuel Pellet and Fuel Rod Assembly for a Commercial Nuclear Power Reactor

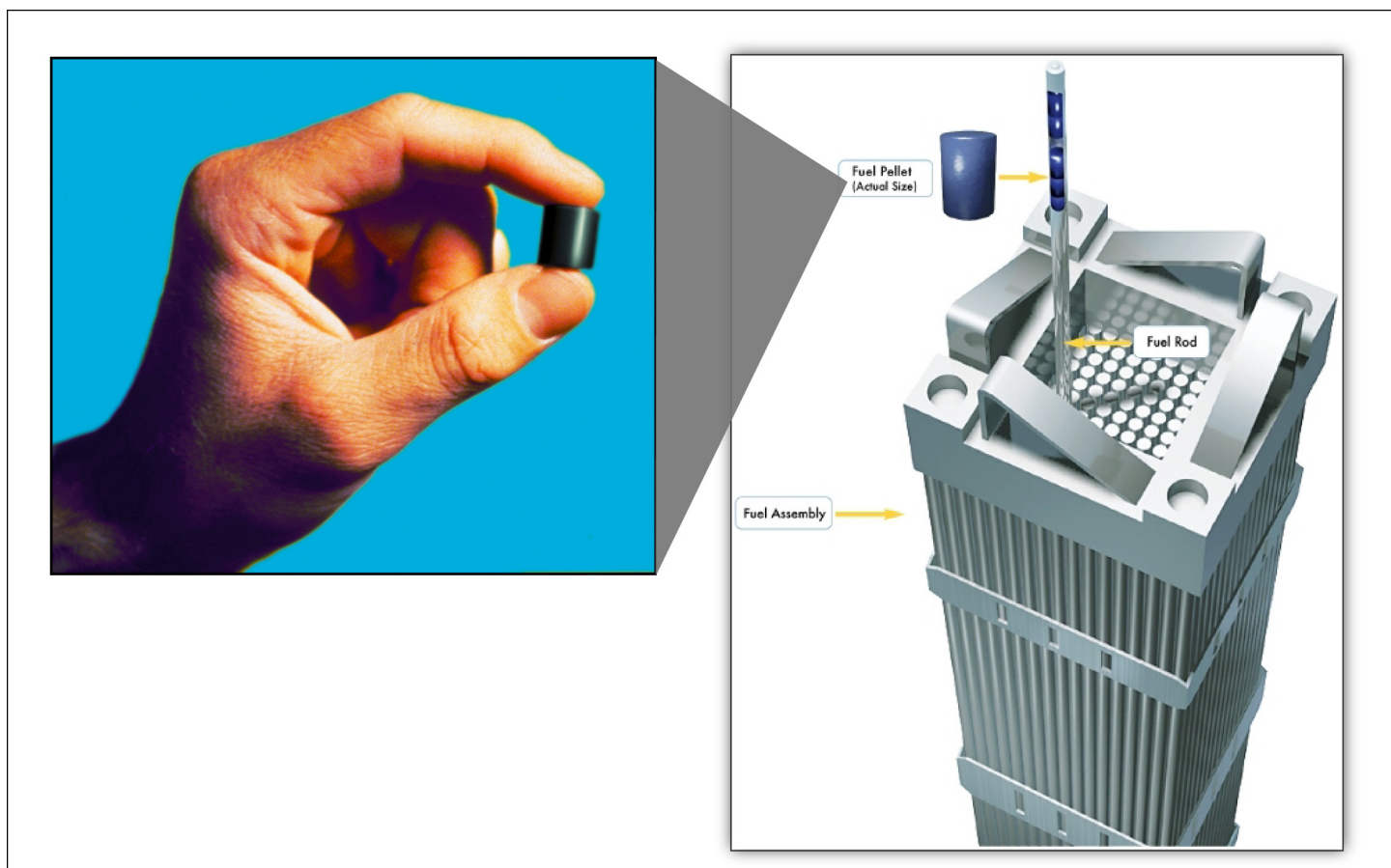

Source: Nuclear Energy Institute. | GAO-15-141

Each fuel assembly is typically used in the reactor from 4 to 6 years, after which most of the uranium dioxide is no longer cost-efficient at producing energy. Reactor operators typically discharge about one-third of the fuel assemblies from a reactor every 18 months to 2 years and place the spent nuclear fuel in a pool to cool. Most commercial spent nuclear fuel is stored immersed in pools of water designed to cool and isolate it from the environment. Water circulates in the pool to remove the heat generated from the radioactive decay of some of the radioisotopes. In recent years, reactor operators have used fuel that is burned longer in the reactor

under the same operating conditions, resulting in higher “burn-up” and higher decay heat in comparison to the lower burn-up fuel that had been in use.⁸ The pools of water for cooling spent nuclear fuel are typically about 40 feet deep, with at least 20 feet of water covering the spent fuel. Figure 2 shows a typical spent nuclear fuel pool.

Figure 2: Spent Nuclear Fuel in Wet Pool Storage

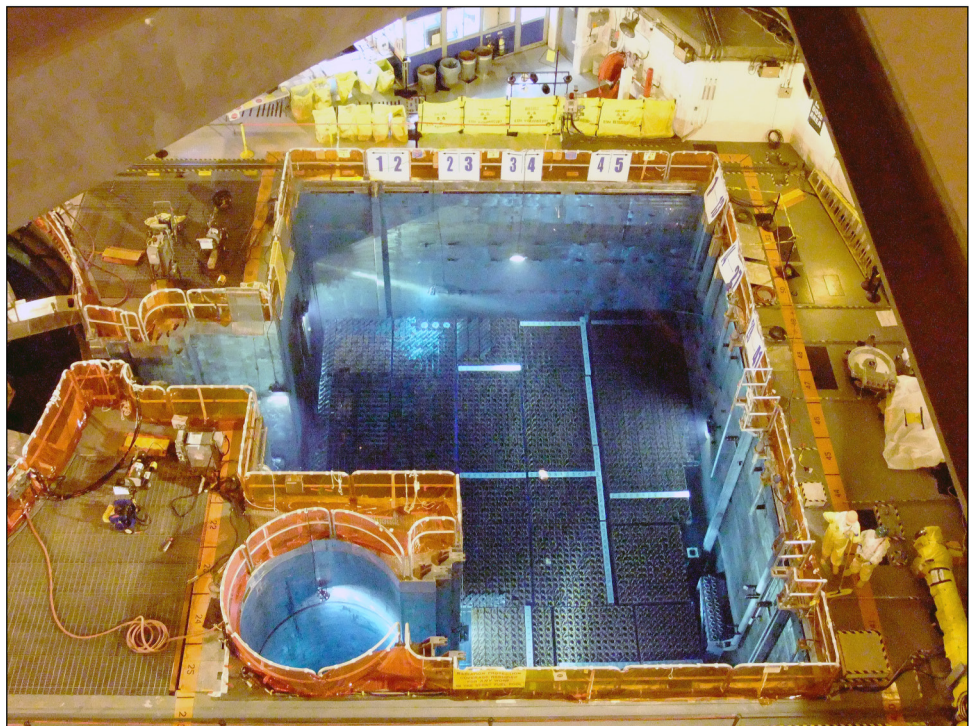

Source: Nuclear Energy Institute. | GAO-15-141

Industry practice has been to store the spent nuclear fuel in the pools for at least 5 years, with an industry expectation that, at some point, DOE would begin to accept it. Spent nuclear fuel typically must remain in a pool for at least 5 years to decay enough to remain within the heat limits currently allowed for dry cask storage systems. Spent nuclear fuel can be

⁸Reactor fuel “burn-up” is a measure of the energy that has been produced by the fuel. High burn-up fuel generally has been in a reactor longer than low burn-up fuel and is defined as having a burn-up higher than 45,000 megawatt days per metric ton.

sufficiently cool to load into dry storage systems earlier than 5 years, but doing so is generally not practical. Some dry storage systems, depending on the rated heat load, may not accommodate a full load of spent nuclear fuel. High burn-up fuel may have to remain in a pool longer than low burn-up fuel to cool sufficiently.

The pools at commercial nuclear power reactors have largely reached their maximum capacities, however. When spent nuclear fuel is discharged from a reactor at a plant where the spent nuclear fuel pool is at maximum capacity, spent nuclear fuel equal to the amount of spent nuclear fuel discharged from the reactor must be transferred to dry storage. The dry storage systems typically consist of either a thick-walled, bolted steel vertical cask, or a welded steel canister inside a vertical or horizontal steel-reinforced concrete cask. Dry storage systems are designed with thick steel and concrete walls to provide radiation shielding and passive pathways for removal of spent nuclear fuel decay heat, such as air vents in the casks. In one typical process of transferring spent fuel to dry storage, reactor operators place a steel canister inside a larger steel transfer cask and lower both into a pool. Spent nuclear fuel is loaded into the canister, a lid is placed on the canister, and then both the canister and transfer cask are removed from the pool. The transfer cask shields nearby workers from the radiation produced by the spent nuclear fuel in the canister. The water is drained and a lid is welded onto the canister. Then the canister and transfer cask are aligned with a storage cask and the canister is maneuvered into the storage cask. The transfer cask can be re-used. The storage casks, in either vertical or horizontal designs (see fig. 3), are usually situated on a large concrete pad with safety and security measures, such as radiation detection devices and intrusion detection systems.

Figure 3: Dry Cask Storage System for Spent Nuclear Fuel

At some nuclear reactors across the country, spent fuel is kept on site, above ground, in systems basically similar to the ones shown here. Once the spent fuel has cooled, it is loaded into special canisters. Each canister is designed to hold approximately 2-6 dozen spent fuel assemblies, depending on the type of assembly. Water and air are removed. The canister is filled with inert gas, and sealed (welded or bolted shut).

- 1 Some canisters are designed to be placed vertically in robust above-ground concrete or steel structures.

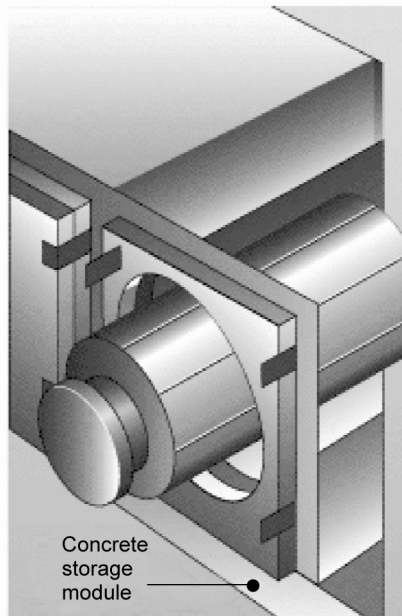
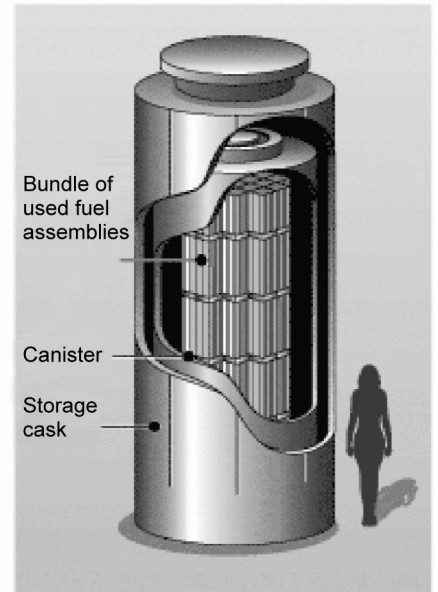

- 2 Some canisters are designed to be stored horizontally in above-ground concrete modules, each of which is about the size of a one-car garage.

Source: NRC. | GAO-15-141

NRC requires that spent fuel in dry storage be stored in approved systems that offer protection from significant amounts of radiation. NRC requires storage systems to demonstrate compliance with its regulations, including through physical tests of the systems, scaled physical tests, and computer modeling. Once a dry storage system is approved, NRC issues a certificate of compliance for a cask design or a specific license. Figure 4 shows spent nuclear fuel on a concrete pad in dry storage.

Figure 4: Spent Nuclear Fuel in Dry Storage



Source: Portland General Electric Co. | GAO-15-141

Most U.S. reactors were built during the 1960s and 1970s and, after a 40-year licensing period have received a 20-year license extension, and some may apply for subsequent extensions. Nevertheless, these reactors may begin permanently shutting down in large numbers by about 2030 and emptying their pools by about 2040 absent additional license renewals. In the absence of a repository, the reactors' accumulated spent nuclear fuel will be "stranded" in a variety of different dry storage systems, with no easy way of repackaging the spent fuel should repackaging be required to meet future storage or disposal requirements. NRC

regulations require radioactive contamination to be reduced at a reactor to a level that allows NRC to terminate the reactor's license and release the property for other use after a reactor shuts down permanently. This cleanup process is known as decommissioning.⁹

About 2,200 Metric Tons of Spent Nuclear Fuel Is Expected to Accumulate Annually, Mostly in Wet Storage, but This Pace Is Expected to Change as Reactors Shut Down

Spent nuclear fuel is expected to accumulate at an average rate of about 2,200 metric tons per year in the United States, mostly in wet storage, but this rate and the amount in wet storage are expected to decrease as more reactors, as projected, begin to shut down in the 2030s. More specifically, according to data provided by the Nuclear Energy Institute, the rate of accumulation will be about 2,100 metric tons in 2031, decreasing to about 1,200 metric tons in 2040, about 200 metric tons in 2050, and less than 100 metric tons per year from 2051 through 2055, when the last one of the currently operating nuclear power reactors is expected to shut down. These rates assume that except for the few reactors that have announced early permanent shutdown dates, the nation's current reactors continue to operate through a 20-year extended license period without any further license extensions and continue to produce spent nuclear fuel at the same rate, and that no new reactors are brought online.¹⁰

⁹See GAO, *Nuclear Regulation: NRC's Oversight of Nuclear Power Reactors' Decommissioning Funds Could Be Further Strengthened*, [GAO-12-258](#) (Washington, D.C.: Apr. 5, 2012). Decommissioning must generally be completed within 60 years of cessation of reactor operations. Reactor operators may either immediately decontaminate and dismantle their reactor sites or monitor and maintain them as the spent nuclear fuel cools and decays over a longer period.

¹⁰NRC has issued licenses for the construction of four new reactors in South Carolina and Georgia. The Nuclear Energy Institute data did not include spent nuclear fuel that is expected to be generated from these reactors. The Nuclear Energy Institute data also did not include spent nuclear fuel that might be generated from a second license extension of existing nuclear power reactors. The Nuclear Energy Institute stated that some operators of reactors are considering a second license renewal.

Shutdown of Nuclear Reactors in the United States

Of the 118 nuclear reactors in the United States, 18 reactors have permanently shut down. Three of these reactors are located on a site that also has an operating reactor. The remaining 15 reactors are located on 12 sites where the reactors have been or will be dismantled and decontaminated. After this decommissioning, the site can be used for other purposes and the only relic remaining at the site will be the spent nuclear fuel storage facility and the associated safety and security infrastructure.

Source: DOE. | GAO-15-141

By the end of fiscal year 2013, DOE reported that it had signed contracts with owners and generators of spent nuclear fuel involving 118 reactors. The spent nuclear fuel from these 118 reactors is stored at 75 sites in both wet and dry storage systems. Several reactors share the same site. For example, the Palo Verde site in Arizona has 3 operating reactors.

In 2013, about 70 percent of accumulated spent nuclear fuel—about 50,000 metric tons—was stored in pools, with the remaining 30 percent—about 22,000 metric tons—in dry storage. Figure 5 shows the 75 spent nuclear fuel wet and dry storage sites, including shut-down sites, in the United States.

Interactive Graphic

Figure 5: Commercial Spent Nuclear Fuel Stored in Wet, Dry, and Shutdown Storage Sites

Instructions: Online, hover over the symbols in the key for more information.
To print a version containing text, see appendix III, page 46

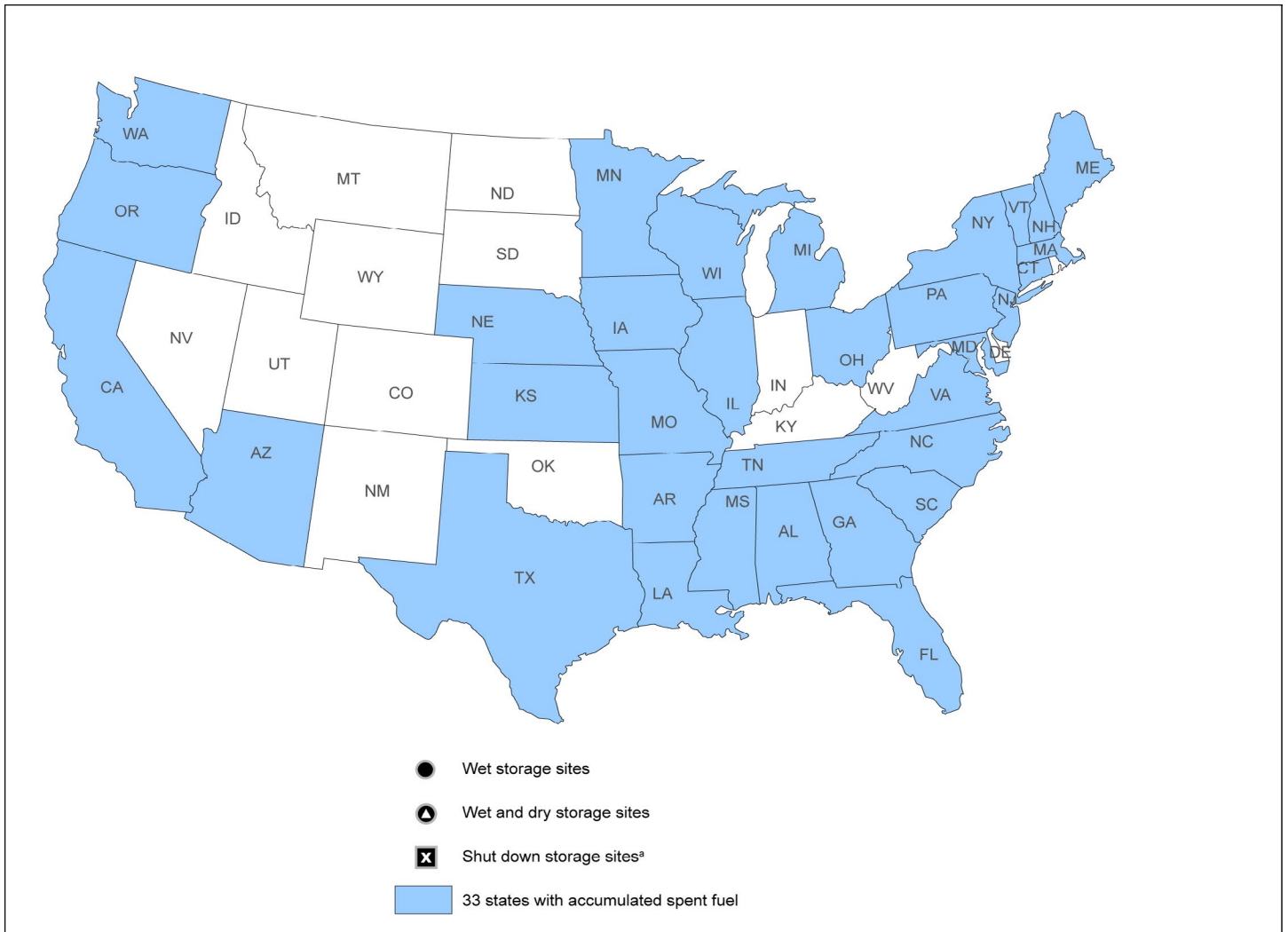

Sources: GAO analysis of NRC and DOE data, as of July 2014. | GAO-15-141

^aIn addition, there are three permanently shutdown reactors at sites that continue to have operating reactors. The sites that have both shutdown and operating reactors include the Dresden, Indian Point, and Millstone sites. Of the 12 shutdown reactor sites, the Zion site has two permanently shutdown reactors and the San Onofre site has three permanently shutdown reactors.

In the future, more spent nuclear fuel is expected to be put into dry storage for two reasons. First, since most spent nuclear fuel pools have reached their maximum capacities, reactor operators must transfer fuel from the pools to dry storage to make room for newer spent nuclear fuel, a time-consuming and costly process. Second, the amount of spent nuclear fuel transferred to dry storage is expected to increase as reactors shut down and their pools are closed. According to data from the Nuclear Energy Institute, by 2024, the proportion of spent fuel in wet storage and dry storage from currently existing reactors should be roughly equal—about 48,000 metric tons each. By 2040, about 70 percent of the spent fuel is expected to be in dry storage, or about 89,000 metric tons, compared to about 39,000 metric tons in wet storage. By 2067—after the last of the currently operating reactors have shut down—nearly all the 139,000 metric tons of spent fuel expected to be generated by currently operating reactors is expected to be in dry storage. Figure 6 shows the estimated amounts of spent nuclear fuel accumulation and transfer from wet storage to dry storage through 2067.

Figure 6: Estimated Amount of Accumulation of Spent Nuclear Fuel in Wet and Dry Storage through 2067

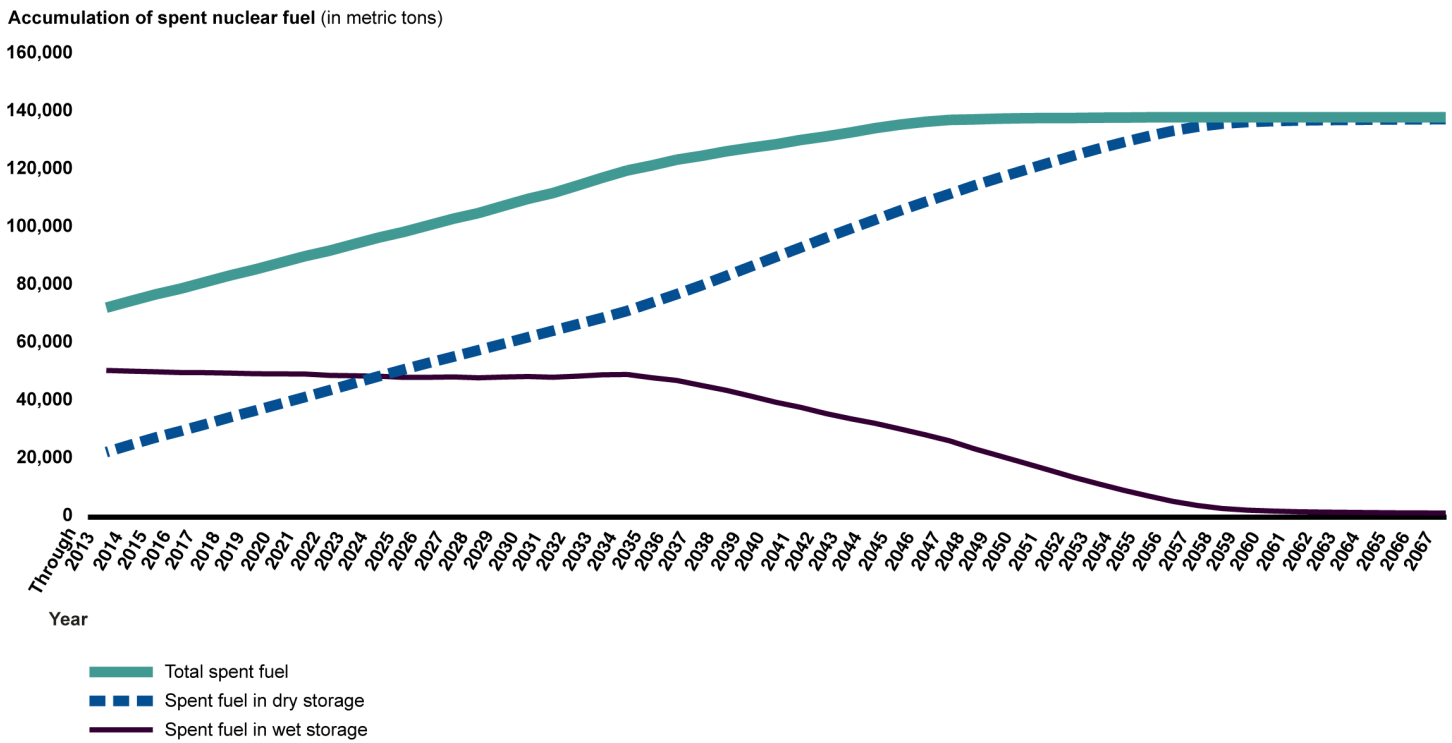

Source: GAO analysis of Nuclear Energy Institute data. | GAO-15-141

Note: The rates in the figure assume that except for the few reactors that have announced early permanent shutdown dates, the nation's current reactors continue to operate through a 20-year extended-license period without any further license extensions and continue to produce spent nuclear fuel at the same rate that no new reactors are brought online, and that generation of spent nuclear fuel declines as reactors shut down.

Federal Liability for Spent Nuclear Fuel Management Is Based on Costs Incurred Because DOE Has Not Met Contract Obligations

Federal liability for managing spent nuclear fuel has been based on costs that owners and generators of this fuel have paid because DOE has not met its contractual obligations to begin disposing of this fuel, and DOE's estimate of future liability—\$21.4 billion through 2071—is based on how long the federal government is expected to pay these costs. This estimate is based on DOE's strategy to begin accepting spent nuclear fuel in 2021 and assumes no delays in their schedule.

Generally, the U.S. Court of Federal Claims has held that the federal government's liability covers the cost of managing the spent nuclear fuel that DOE was obligated to begin disposing of in 1998. The Department of Justice has also agreed to pay such costs as a result of settlement agreements.¹¹ (See app. IV for additional information on the settlement agreements.) Under the standard contract, DOE was obligated to take title to and dispose of a certain quantity of spent nuclear fuel beginning in 1998. The order in which spent nuclear fuel was to be picked up is based on the order in which it was removed from reactors—or the oldest fuel first. The owner or generator was expected to pay continued storage costs for the spent nuclear fuel that DOE was not obligated to pick up.

Some of the costs for which the federal government has been liable have related to expanding wet storage of spent nuclear fuel. For example, the federal government has compensated owners and generators for replacing lower-density storage racks with higher-density storage racks in pools to increase the capacity of the pools. The capacity of nearly all the spent nuclear fuel pools in the country has been expanded to the extent practical, and according to NRC, most pools have been filled to their maximum prudent capacities.

The majority of the types of costs for which the federal government has been liable have pertained to dry storage costs of spent nuclear fuel. Some have been one-time costs, such as the cost of constructing a concrete pad for storing spent nuclear fuel once it has been transferred from the pools to dry canisters or casks. Constructing a concrete storage pad typically costs from about \$5.5 million to \$6.5 million, but can range higher if additional equipment or special design requirements are needed.

¹¹According to a Department of Justice official, the department has settled as many of the cases brought by owners and generators of spent nuclear fuel as possible out of court to reduce the time and expense of litigation and to achieve some consistency in what the government should expect to pay in potential future claims.

Other dry storage costs are recurring; for example, the cost of the canisters themselves, which depends on the size of the canister and type of spent nuclear fuel stored in it. Table 1 shows the differences in sizes of canisters, which typically cost from \$700,000 to \$1.5 million, and how the numbers of canisters for which the federal government may have to pay can vary from site to site.

Table 1: Typical Reactor Characteristics, Canister Storage Capacity

Type of reactor	Typical core size	Typical discharge	Typical capacity of dry storage canister	Typical number of canisters to be loaded to keep pace with discharge
Pressurized water reactor ^a	193 assemblies (87 metric tons)	72 to 84 assemblies (32 to 38 metric tons)	32 assemblies (14.4 metric tons)	3-6 canisters annually
Boiling water reactor ^a	650 assemblies (101 metric tons)	224 assemblies every 24 months (40 metric tons)	61 assemblies (11 metric tons)	4 canisters biennially

Source: GAO analysis of Electric Power Research Institute and Nuclear Energy Institute data. | GAO-15-141

^aFuel for nuclear reactors differs according to the type of reactor. In the United States, about two-thirds of the 100 operating reactors are pressurized water reactors, with the remainder being boiling water reactors. Fuel assemblies for both types of reactors are typically 14 feet tall, but such assemblies for pressurized water reactors are about 8.5 inches square compared with about 6 inches square for boiling water reactors.

Another recurring cost is the cost of transferring spent nuclear fuel in the canisters from the pools to dry storage. Table 2 reflects typical costs associated with the transfer of spent nuclear fuel from wet to dry storage that may contribute to federal liabilities.

Table 2: Typical Costs Associated with Transferring Spent Nuclear Fuel in Canisters from Wet to Dry Storage

Component	Typical Costs
Labor costs to transfer spent nuclear fuel from pool to dry storage ^a	\$150,000 to \$550,000
Transfer cask	\$1.5 million to \$3 million
Crawler-type transporter	\$1 million to \$1.5 million
Vertical storage cask	\$250,000 to \$350,000
Horizontal storage module	\$500,000 to \$600,000
Design, licensing, and construction	\$5.5 million to \$42 million
Annual operations	\$100,000 to \$300,000 for operating reactor site \$2.5 million to \$6.5 million for permanently shutdown reactor site

Source: GAO analysis of Nuclear Energy Institute data. | GAO-15-141

Note: Some items, such as a transfer cask and a transporter can be re-used and may reflect one-time costs. In addition, costs for the transfer cask and transporter reflect purchase costs, but this equipment could be leased, rather than purchased. The costs for canisters, ranging from \$700,000 to \$1.5 million, are not included in this table.

Interactive Graphic

Figure 7: Process and Costs of Transferring Spent Nuclear Fuel from Wet to Dry Storage

Instructions: Online, hover over the number in the figure for more information.
To print a version containing text, see appendix V, page 52

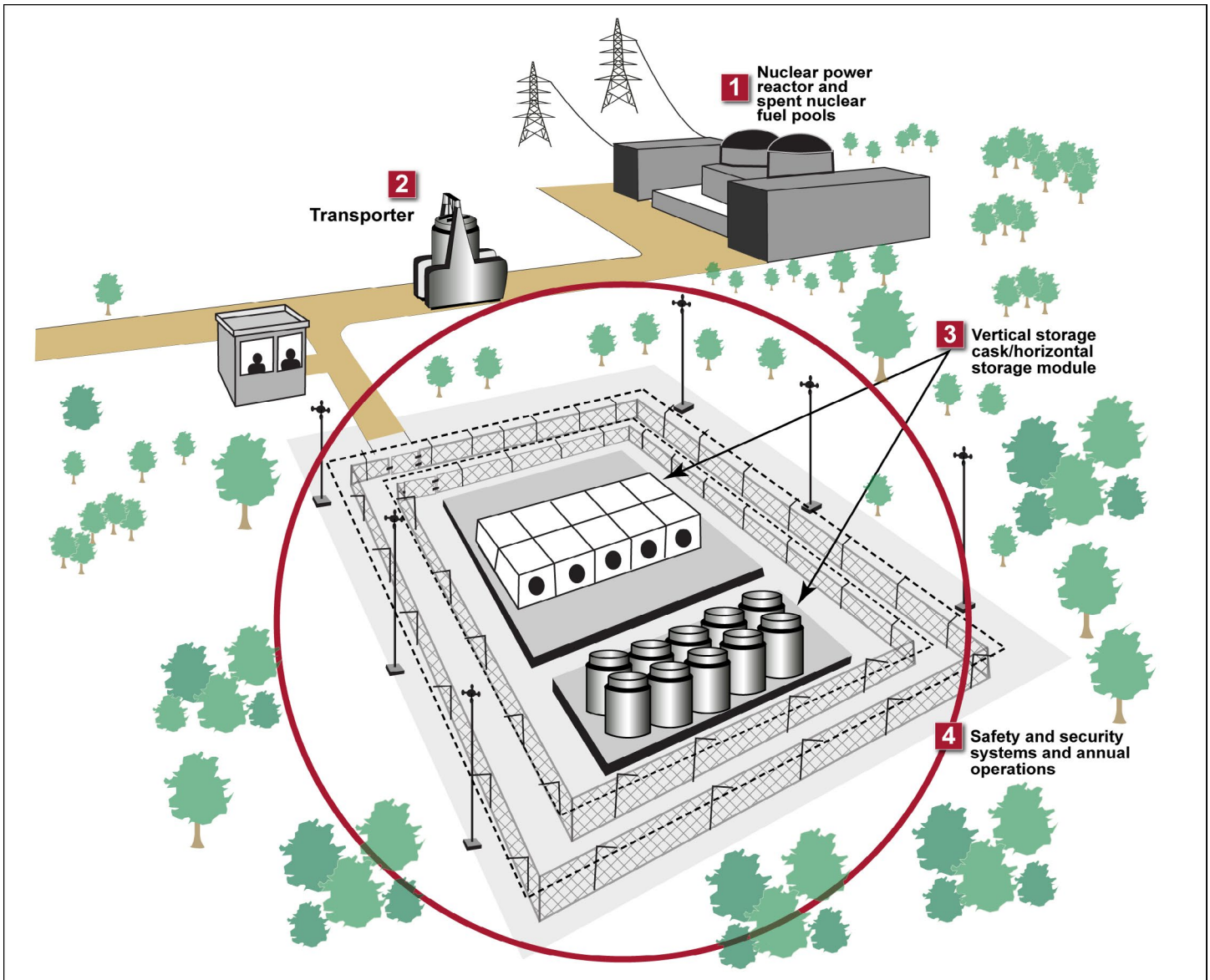

Source: GAO analysis of Nuclear Energy Institute data. | GAO-15-141

Note: Since each dry storage facility is unique in terms of proximity to the reactor, size, and type of storage systems, this figure is only illustrative and does not show a typical dry storage facility. For example, vertical and horizontal storage systems are typically not found at the same site.

DOE's estimate of future liability is based on how long DOE expects the federal government to continue to pay for managing spent nuclear fuel that DOE was obligated to have begun disposing of if it had begun picking up the fuel in 1998. DOE's most recent estimate of this liability is \$21.4 billion through 2071. This estimate assumes that DOE will begin accepting spent nuclear fuel in 2021 and complete the process in 2071, ending the federal government's liability. However, DOE has previously extended the dates in its liability estimates several times. For example, in the fiscal year 2006 liability estimate, DOE estimated (1) that the federal liability was \$6.9 billion, (2) that DOE would begin accepting spent nuclear fuel in 2017, and (3) it would complete the process by 2055. Each time extension adds to the federal government's liability.

Experts and Stakeholders Identified Challenges to and Suggestions for Managing Spent Nuclear Fuel at Interim Storage Facilities within DOE's Time Frames

Experts and stakeholders in the area of spent nuclear fuel management, including DOE and other government officials, identified four major types of challenges to the federal government's ability to meet DOE's time frames for managing spent nuclear fuel at consolidated interim storage facilities. First, DOE does not have legislative authority to fully implement its strategy, although DOE officials said they are conducting some planning activities that are allowed by the NWPAA. Second, the licensing process could take more time than DOE has allowed. Third, there are several technical challenges to transporting some spent nuclear fuel. Fourth, achieving sustainable public acceptance of transporting and storing spent nuclear fuel is a societal challenge that will need to be addressed irrespective of any policy that is implemented and that experts said DOE could mitigate with a coordinated outreach strategy. Figure 8 summarizes the four major types of challenges identified by experts and stakeholders with whom we spoke.

Figure 8: Four Major Types of Challenges Identified By Experts and Stakeholders on Federal Efforts to Manage Spent Nuclear Fuel at Consolidated Interim Storage Facilities

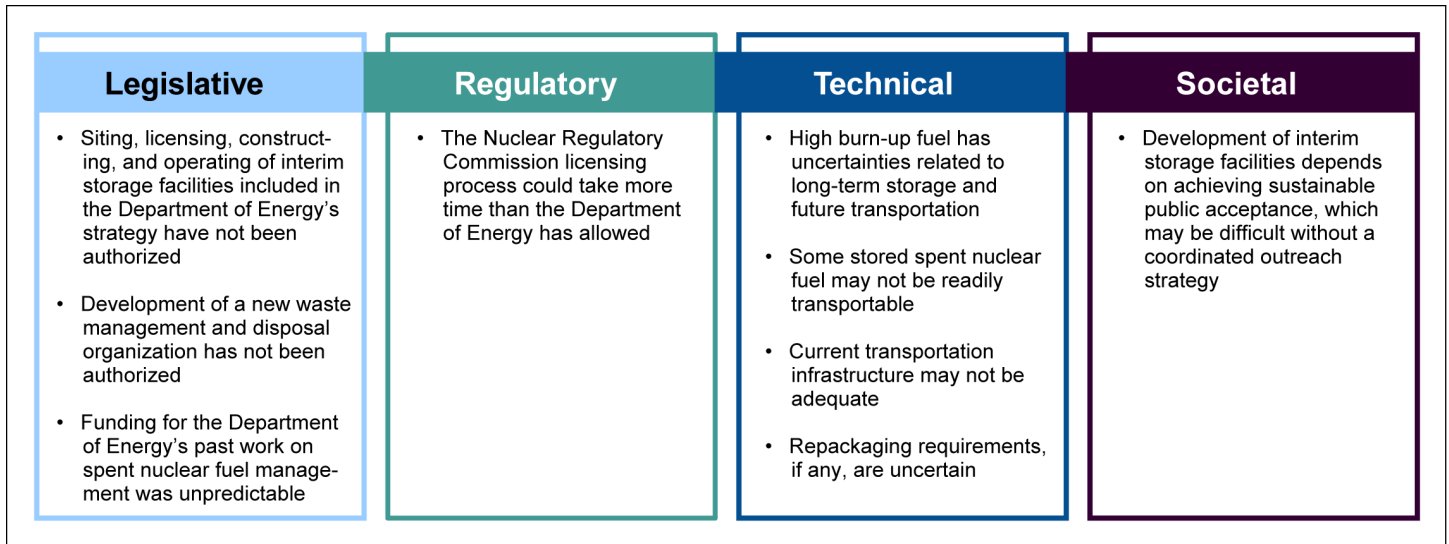

Source: GAO. | GAO-15-141

DOE Does Not Have Legislative Authority to Fully Implement Its Strategy

In general, experts identified the legislative challenges as critical to implementing DOE's strategy within the time frames proposed. In particular, the experts pointed out that new legislative authority is needed for developing interim storage that is not tied to Yucca Mountain, creating a new waste management organization, and providing predictable funding for carrying out spent nuclear fuel management. However, experts and stakeholders generally noted that because the Congress has not agreed on a new path forward for managing spent nuclear fuel since funding was suspended in 2010, nor have DOE officials proposed legislation requesting new authority, obtaining specific legislative authority in time to meet DOE's proposed time frames might be challenging.

Siting, Licensing, Constructing, and Operating of Interim Storage Facilities Included in DOE's Strategy Have Not Been Authorized

As we reported in November 2009 and August 2012,¹² provisions in NWPA that authorize DOE to arrange for consolidated interim storage have either expired or are unusable because they are tied to milestones in the development of a repository at Yucca Mountain that have not been met. DOE officials and experts from industry agreed with this assessment, and they noted that the federal government's ability to site, license, construct, and operate a consolidated interim storage facility is dependent upon new legislative authority. Some industry representatives we spoke with said that such authority would be needed by the end of 2014 to meet DOE's 2021 goal to begin operations at a pilot interim storage facility. DOE officials noted that their strategy is available to Congress and is intended to initiate discussions on developing a future path forward or future policy to be implemented. However, experts and stakeholders generally noted that there is not agreement between the House and Senate on a path forward, and therefore obtaining such authority in 2014 is unlikely. Pending such agreement, the agency has been planning what it can do, and the agency has undertaken some activities allowed under current authority to inform the development of an interim storage facility. For example, the agency is reviewing reports submitted by contractors in 2013 on design concept alternatives for a consolidated interim storage facility. DOE officials said, however, that the agency's strategy could not be fully implemented until Congress provides direction on a path forward.

Development of a New Waste Management and Disposal Organization Has Not Been Authorized

DOE's strategy calls for a new waste management and disposal organization for managing spent nuclear fuel; however, Congress has not authorized such an organization. According to DOE, a new organization separate from DOE is needed to "provide stability, focus, and credibility to build public trust and confidence." Industry representatives and presenters at a Bipartisan Policy Center Conference in 2014 agreed that DOE is not the right organization to implement its strategy because the public lacks confidence in the agency and its ability to move forward in managing spent nuclear fuel. In addition, an expert from industry said that a new organization designed to implement a consent-based process would be better suited to site a consolidated storage facility—a view that

¹²GAO, *Spent Nuclear Fuel: Accumulating Quantities at Commercial Reactors Present Storage and Other Challenges*, [GAO-12-797](#) (Washington, D.C.: Aug. 15, 2012) and *Nuclear Waste Management: Key Attributes, Challenges, and Costs for the Yucca Mountain Repository and Two Potential Alternatives*, [GAO-10-48](#) (Washington, D.C.: Nov. 4, 2009).

Funding for DOE's Past Work on Spent Nuclear Fuel Management Was Unpredictable, and Experts Said More Predictability Is Essential

is generally consistent with one of our past matters for congressional consideration noting that an independent organization, outside DOE, could be more effective in siting and developing a permanent repository for the nation's nuclear waste.¹³ Similarly, the Blue Ribbon Commission on America's Nuclear Future recommended establishing a new federal corporation or similar independent organization to implement, among other things, a consent-based siting process. Such an organization would be more effective because it would be less vulnerable to political interference, according to the commission.

However, experts from industry told us that even with congressional authorization, such an organization would take time to create, in part, according to an industry expert, because a new organization would need to acquire personnel, implement a quality assurance program, and develop an implementation plan. These could take from 2 to 5 years, according to the experts.

In 2011, we reported that funding for DOE's work related to Yucca Mountain was unpredictable, noting that DOE's annual appropriations related to spent nuclear fuel management had varied by as much as 20 percent from year to year;¹⁴ further, DOE's average annual appropriations fell about \$90 million short of the amount DOE requested each year.¹⁵ We reported that this unpredictability made long-term planning difficult, and we suggested that Congress may wish to consider whether a more predictable funding mechanism would enhance future spent nuclear fuel management efforts. According to experts from industry and community action groups we interviewed, having sufficient funds consistently available is essential for any spent nuclear fuel management effort. However, as noted earlier, there is not agreement on a path forward—including developing a more predictable funding mechanism. DOE reported in 2001 that the budgetary requirements enacted by Congress,¹⁶

¹³[GAO-11-229](#).

¹⁴Established by the NWPA in 1983, DOE's office responsible for spent nuclear fuel was in the Office of Civilian Radioactive Waste Management (OCRWM), which was dismantled when DOE terminated Yucca Mountain. Currently, DOE's Office of Nuclear Energy is responsible for spent nuclear fuel related activities.

¹⁵[GAO-11-229](#).

¹⁶See Department of Energy, Office of Civilian Radioactive Waste Management, *Alternative Means of Financing and Managing the Civilian Radioactive Waste Management Program*, DOE/RW-0546 (Washington, D.C.: August 2001).

subsequent to the creation the Nuclear Waste Fund,¹⁷ reduced financial flexibility. These funding challenges were also echoed by the Blue Ribbon Commission, which recommended that a new, more predictable, funding mechanism be developed.¹⁸

Experts and Stakeholders Identified Regulatory Challenges Related to Licensing a Consolidated Interim Storage Facility

Because the NRC licensing process is time consuming, it may be difficult for DOE or an alternative waste management and disposal organization to begin operations at a pilot interim storage facility in 2021 and a consolidated interim storage facility in 2025, as called for in DOE's strategy. The NRC licensing process cannot begin until an interim storage site has been selected, which, as stated previously in this report, cannot happen under existing legislative authority. Some industry experts, as well as a scientist from a national laboratory, told us licensing an interim facility could be achieved within 5 to 7 years of site selection. Other industry experts and a community action group told us licensing will more likely be an 8- to 10-year process because of the potential for legal concerns raised by the public. Such concerns may originate with an environmental impact statement—such a statement is required before a license can be granted, and it allows for public input that may require adjudication. The NRC hearing process could also lengthen the licensing process. For example, in 2006, after a 9-year licensing process, a consortium of electric power companies called Private Fuel Storage obtained an NRC license for a private consolidated storage facility on an Indian reservation in Utah.¹⁹ As we previously reported, the delay in licensing Private Fuel Storage was due to state opposition and to challenges raised during the license review process.

¹⁷In return for the federal government's taking responsibility for disposing of the spent nuclear fuel, the owners and operators agreed to make quarterly payments, beginning in 1983, into a Nuclear Waste Fund statutorily established under NWPA. According to DOE, the current value of the fund is approximately \$28.2 billion, which—until this year— included annual deposits of approximately \$750 million in fee collections and \$1.5 billion in accrued interest.

¹⁸Blue Ribbon Commission on America's Nuclear Future, *Report to the Secretary of Energy* (January 2012).

¹⁹Private Fuel Storage obtained a 20-year license from NRC with an option for an additional 20-year extension. The license allowed storage of up to 40,000 metric tons of commercial spent nuclear fuel. Though Private Fuel Storage was licensed in 2006, it never began operations, in part because of other land-use decisions restricting new construction.

Experts and Stakeholders Identified Technical Challenges That Could Be Resolved over Time

Experts described technical challenges that could be resolved with sufficient time. In particular, there are uncertainties regarding transportation of spent nuclear fuel, including the uncertainties related to the safety of high burn-up fuel during transportation,²⁰ readiness of spent nuclear fuel to be transported under current guidelines, and sufficiency of the infrastructure to support transportation. In addition, there are uncertainties related to repackaging spent nuclear fuel for transportation. According to DOE officials, the agency is taking steps to begin addressing technical challenges, but not all of the challenges can be addressed until uncertainties regarding the path forward are resolved.

High Burn-Up Fuel Has Uncertainties Related to Long-term Storage and Future Transportation

According to some industry experts, more information is needed about how to safely store and transport high burn-up fuel. Before 2000, most fuel discharged from U.S. nuclear power reactors was considered low burn-up fuel, and consequently, the industry has had decades of experience in storing and transporting it. In addition, the first dry storage canisters were loaded in 1986. One of these, containing low burn-up fuel, was opened 15 years later and the spent nuclear fuel inspected. The spent nuclear fuel was found to be in good condition, giving NRC additional confidence in the safe storage and transport of spent nuclear fuel. According to NRC, there has been considerable analysis performed on high burn-up fuel, but because it has only been used for about the past 10 years, there has been little testing performed on it. According to various reports from DOE, NRC, the Electric Power Research Institute, and the Nuclear Waste Technical Review Board, as well as experts we spoke with, uncertainties exist on how long high burn-up fuel can be stored and then still be safely transported. Once sealed in a canister, the spent fuel cannot easily be inspected for degradation.

²⁰Reactor fuel burn-up is a measure of the energy that has been produced by the fuel. High burn-up fuel generally has been in a reactor longer than low burn-up fuel and is defined as having a burn-up higher than 45,000-megawatt days per metric ton.

Description of Concerns Related to High Burn-Up Fuel

According to the Nuclear Regulatory Commission (NRC), burn up is considered as part of NRC's reviews of spent nuclear fuel cask designs because each dry storage system has limits on temperature and radiation, both of which are higher for high burn-up fuel. While in the reactor, hydrogen gas is generated and is absorbed by the cladding. Then, during the transfer from wet to dry storage, the spent nuclear fuel is loaded into a storage cask, which is removed from the storage pool and drained of water to dry the fuel. During the drying process, the fuel heats up, dissolving the hydrogen in the cladding structure. While the spent nuclear fuel is still hot and the cladding is still supple, there is little uncertainty in storing or transporting it, as long as temperature and radiation limits are met. However, as the spent nuclear fuel cools over extended periods in dry storage, the dissolved hydrogen can change the characteristics of the cladding and, if certain conditions exist, can cause the cladding to become brittle over time. The extent of the changes in cladding depend on the burn-up of the fuel, the type of cladding, and the temperatures reached during the drying process, and need to be accounted for in the storage and transportation of high burn-up spent nuclear fuel. There is not the same level of concern about changes in the cladding causing brittleness with low burn-up fuel because not as much hydrogen becomes dissolved in the cladding. In addition, there is more data available on the performance of low burn-up fuel during storage, since low burn-up fuel has been stored for long periods.

Source: GAO analysis of data from the Electric Power Research Institute, NRC, the Nuclear Waste Technical Review Board, and Pacific Northwest National Laboratory. | GAO-15-141

As of August 2014, NRC officials told us that they had analyzed laboratory tests and models developed to predict the changes that occur during dry storage and the results indicate that high burn-up fuel will maintain its integrity over very long periods of storage and can eventually be safely transported. However, NRC officials said they continue to seek additional evidence to confirm their position that long-term storage and transportation of high burn-up spent nuclear fuel is safe. In an effort to obtain evidence confirming the test and modeling results, DOE and the Electric Power Research Institute have planned a joint development project to load a special dry cask storage system with high burn-up fuel in mid-2017 and, using instrumentation built into the cask, monitor the spent nuclear fuel over a period of about 10 years. At that point, DOE and the Electric Power Research Institute expect to transport the canister to an appropriate facility and open it to inspect the high burn-up fuel and its

cladding, as well as the cask, for any indication of damage or degradation. According to DOE and the Electric Power Research Institute, the project's execution has been planned through 2018 and many future elements of the project still need to be developed. Experts and stakeholders expressed various views regarding the level of uncertainty of the safe transportation of high burn-up fuel after long-term storage. But one theme conveyed during our discussions with them was that high burn-up fuel would continue to be stored in dry storage canisters without knowing how long the spent nuclear fuel would be stored or how safe future transportation would be. DOE officials stated that their strategy would not involve transportation of large amounts of high burn-up fuel until at least 2025 and that even then, there is likely going to be enough low burn-up fuel to ship for the first several years, giving more time for the development project to yield results.

Some Stored Spent Nuclear Fuel May Not Be Readily Transportable

Because the guidelines governing dry storage of spent nuclear fuel allow higher temperatures and external radiation levels than guidelines for transporting the fuel, some of the spent nuclear fuel in dry storage may not be ready to be moved to an interim storage facility in time to meet DOE's time frames. For example, according to the Nuclear Energy Institute, as of 2012, only about 30 percent of spent nuclear fuel currently in dry storage is cool enough to be directly transportable. For safety reasons, transportation guidelines do not allow the surface of the transportation cask to exceed 185 degrees Fahrenheit (85 degrees Celsius) because the spent nuclear fuel is traveling through public areas using the nation's public transportation infrastructure.²¹ NRC's guidelines on spent nuclear fuel dry storage limit spent nuclear fuel temperature to 752 degrees Fahrenheit (400 degrees Celsius).²² Reactor sites, where spent nuclear fuel dry storage systems are typically found, are usually in secluded areas with a buffer zone between the spent nuclear fuel and the public. Dry storage sites are also usually located so that workers and the public have minimal exposure to radiation from the spent nuclear fuel. According to experts from industry, spent nuclear fuel has typically been stored in large dry storage canisters to maximize storage capacity and

²¹See NRC, Office of Nuclear Material Safety and Safeguards, *Standard Review Plan for Transportation Packages for Spent Nuclear Fuel*, NUREG-1617 (Washington, D.C.: March 2000).

²²See NRC, Office of Nuclear Material Safety and Safeguards, *Standard Review Plan for Spent Fuel Dry Storage Systems at a General License Facility*, NUREG-1536 Rev.1 (Washington, D.C.: July 2010).

minimize costs. Spent nuclear fuel stored in the large canisters, however, may have temperatures that exceed the limits of transportation guidelines.

Scientists from the national laboratories and experts from industry suggested three options for dealing with the stored spent nuclear fuel so it can be transported safely: (1) the spent nuclear fuel may be left to cool and decay at reactor sites, (2) the spent nuclear fuel may be repackaged into smaller canisters that reduce the heat and radiation, or (3) a special transportation “overpack” may be developed to safely transport the spent nuclear fuel in the current large canisters. Since Congress has not agreed on a new path forward since funding was suspended in 2010, it may be difficult to assess the options.

Current Transportation Infrastructure May Not Be Adequate

In a 2013 report, DOE states that the preferred mode for transporting spent nuclear fuel to a consolidated interim storage facility would be rail.²³ However, several experts from industry pointed out that not all of the spent nuclear fuel currently in dry storage is situated near rail lines; also, one of these experts said that procuring qualified rail cars capable of transporting spent nuclear fuel will be a lengthy process. Storage sites without access to a rail line may require upgrades to the transportation infrastructure or alternative modes of transportation to the nearest rail line. Constructing new rail lines or extending existing rail lines could be a time-consuming and costly endeavor. In addition, an industry official noted that if spent nuclear fuel were trucked to the nearest rail line, the federal government would have to develop a safe method of transferring the spent nuclear fuel from heavy haul trucks onto rail cars. In September 2013, DOE completed a preliminary technical evaluation of options available and needed infrastructure for DOE or a new waste management and disposal organization to transport spent nuclear fuel from shut-down sites to a consolidated interim storage facility. According to DOE officials, currently there is no need to make a decision regarding how best to move forward with the study results because there is, at this time, no site and

²³See DOE, *Office of Fuel Cycle and Research Development, A Project Concept for Nuclear Fuels Storage and Transportation*, FCRD-NFST-2013-000132 Rev. 1 (June 15, 2013).

no authorization to site, license, construct, and operate a consolidated interim storage facility.²⁴

DOE's Preliminary Evaluation of Removing Spent Nuclear Fuel from Shutdown Sites

DOE's "Preliminary Evaluation of Removing Used Nuclear Fuel from Shutdown Sites" looked at 12 permanently shutdown sites, which included Maine Yankee, Yankee Rowe, Connecticut Yankee, Humboldt Bay, Big Rock Point, Rancho Seco, Trojan, La Crosse, Zion, Crystal River, Kewaunee, and San Onofre. The evaluation found that some shut-down sites, because the facilities have been decommissioned and lack onsite infrastructure, required multiple transportation modes such as heavy-haul-truck to rail, barge to rail, and in the cases of Kewaunee and Humboldt Bay, potentially heavy-haul-truck to barge to rail. For example, Trojan's rail spur was removed during the decommissioning process and Big Rock Point will probably need to truck its spent nuclear fuel 52 miles to Gaylord, Michigan. Some of the sites evaluated have no rail spur, and heavy haul trucking will be required for anywhere from 7.5 miles to potentially 260 miles, depending on the site.

Source: DOE. | GAO-15-141

A DOE official and experts from industry also told us that DOE needs to begin procuring qualified rail cars capable of transporting spent nuclear fuel. DOE officials stated that the agency is beginning to request information from the rail car industry on the rail car design, testing, and approval for the transportation of commercial spent nuclear fuel and anticipates getting responses from interested parties by July 2014. According to an industry representative, the Association of American Railroads established the S-2043 standard, which sets higher standards for transportation of spent nuclear fuel than for normal rail operations. S-2043 requires, for example, on-board safety protection technology unique to spent nuclear fuel shipments and a high performance structural upgrades to accommodate the extra weight of spent nuclear fuel as well as the transportation cask, which according to the industry representative, can weigh up to 500,000 pounds. Industry experts said it may be

²⁴See DOE, *Preliminary Evaluation of Removing Used Nuclear Fuel from Shutdown Sites*, PNNL-22676 Rev.1 (Sep. 30, 2013)

Repackaging Requirements,
If Any, Are Uncertain

challenging to design and fabricate rail cars that meet the S-2043 standard for transporting heavy, fully loaded spent nuclear fuel canisters within DOE's time frames. According to industry experts, it will take, at a minimum, 2 years to design and fabricate a new rail car, in addition to an extensive quality control process to ensure the car meets the S-2043 standard. For example, an industry representative estimated that the entire rail car procurement process may take up to 9 years and another agreed that it may be feasible to begin to move the spent fuel by 2025 if DOE initiates the necessary planning soon. Another option would be for DOE to use what the U.S. Navy has learned from its rail cars designs for its nuclear navy program, which also generates spent nuclear fuel. DOE officials told us they would consider this suggestion as they proceed.

According to experts, some spent nuclear fuel in dry storage may need to be repackaged before it can be transported, and the repackaging is likely to be costly and difficult to accomplish. More specifically, as noted earlier, some dry storage canisters may be too hot or radioactive to meet transportation regulations. If the decision were made to transport the spent nuclear fuel before it had a chance to cool sufficiently, the canisters may have to be repackaged into smaller canisters that meet the transportation regulations. In addition, an industry expert and an expert from a community action group told us repackaging may also be required if current storage canisters, or the spent nuclear fuel in them, has degraded. For example, we previously reported that canisters are likely to last about 100 years,²⁵ after which the spent nuclear fuel may have to be repackaged because of canister degradation.²⁶ By the time such repackaging might be needed, reactor operators may no longer have pools or the necessary infrastructure to undertake the repackaging.

²⁵[GAO-10-48](#).

²⁶In 2010, NRC updated its waste confidence decision and accompanying interim storage rule supporting generic findings of the impacts of storing spent nuclear fuel beyond the licensed life for operation of a nuclear power plant. The 2010 determination found, among other things, that spent nuclear fuel can be stored safely and without significant environmental impacts for at least 60 years beyond the licensed life of a reactor. In 2012, the U.S. Court of Appeals for the District of Columbia Circuit held that the rulemaking required either an environmental impact statement or a finding of no significant environmental impact and remanded the determination and rule back to NRC for further analysis. NRC subsequently completed a generic environmental impact statement and published final revisions to the rule on September 19, 2014.

According to DOE, under provisions of the standard contract, the agency does not consider spent nuclear fuel in canisters to be an acceptable form for waste it will receive. This may require utilities to remove the spent nuclear fuel already packaged in dry storage canisters. Nuclear power reactors that have closed their spent nuclear fuel pools would likely have to transport their spent nuclear fuel to operating reactors with pools, build a new pool, or repackage it in a yet-to-be-developed dry transfer facility. Cutting open these canisters is likely to be an expensive process for utilities that would require using specialized equipment to open welded lids, placing the assemblies back into a wet pool, and then packaging the assemblies into a new cask that DOE would provide under the terms of the standard contract. Such a process would require personnel and equipment, increase worker radiation exposure, increase the potential for fuel damage, produce additional low level waste,²⁷ and, may, according to an industry expert, hinder electricity generating activities. In addition, another industry expert also expressed concerns that re-wetting and re-drying during the repackaging process may lead to cladding degradation issues. However, NRC officials stated that prior to NRC's granting a storage license, each system is analyzed by the applicant and reviewed by the NRC to ensure it can be re-flooded safely with no damage to the spent fuel. Until decisions have been made regarding a new path forward—storage and disposal—repackaging requirements will remain uncertain. However, according to scientists from national laboratories, given a path forward, technical challenges, such as repackaging, can be overcome with time and sufficient funding.

²⁷Low-level waste can range from just-above-natural background levels to much higher levels and generally consists of equipment used in day-to-day management of radioactive materials. Some examples include radioactively contaminated cleaning rags, mops, filters, protective shoe covers, and protective clothing.

Experts and Stakeholders Said Developing Interim Storage Facilities Depends on Achieving Sustainable Public Acceptance, Which May Be Difficult without a Coordinated Outreach Strategy

Experts and stakeholders with expertise in spent nuclear fuel management identified achieving sustainable public acceptance as a challenge that needs to be overcome to implement a spent nuclear fuel management program, and they stated that public acceptance cannot be achieved without a coordinated outreach strategy.

Development of Interim Storage Facilities Depends on Achieving Sustainable Public Acceptance

Reports spanning several decades cite societal and political opposition as key obstacles to siting and building a permanent repository for disposal of spent nuclear fuel. For example, in 1982, the congressional Office of Technology Assessment²⁸ reported that public and political opposition were key factors to siting and building a repository.²⁹ The National Research Council of the National Academies reiterated this conclusion in a 2001 report, stating that the most significant challenge to siting and commencing operations at a repository is societal.³⁰ Our analysis of stakeholder and expert comments indicates the societal and political factors opposing a repository are the same for a consolidated interim storage facility.

This lesson has been borne out in efforts to site, license, build, and commence operations at a consolidated interim storage facility. As we reported in 2011 and as experts and stakeholders reiterated, it may be possible to find a willing community to host a consolidated interim storage facility, but obtaining and sustaining state support may be more difficult because of broader state constituencies and state-federal relations. For example, the Office of the Nuclear Waste Negotiator, established by the

²⁸The Office of Technology Assessment was an office of Congress from 1972 to 1995 that provided congressional members and committees with analysis of scientific and technical issues.

²⁹Office of Technology Assessment, *Managing Commercial High-level Radioactive Waste* (Washington, D.C.: 1982).

³⁰National Research Council of the National Academies, *Disposition of High-Level Waste and Spent Nuclear Fuel: The Continuing Societal and Technical Challenges* (Washington, D.C.: 2001).

NWPA amendments in 1987, tried to broker an agreement for a community to host a repository or interim storage facility. Two negotiators worked with local communities and Native American tribes for several years, but neither was able to conclude a proposed agreement with a willing community by January 1995, when the office's authority expired. In one siting effort, in 1992, a county in Wyoming sought to host a consolidated interim storage facility, but the Wyoming governor stopped that effort. The governor expressed concerns that despite the assurances of federal officials, even those with "personal integrity and sincerity," he could not be sure that the federal government's attitudes or policies would remain the same over the next 50 years or that the state would have any future say in the program. The experience of Private Fuel Storage is another example in which a consortium of owners and generators of spent nuclear fuel found a willing community to host a consolidated interim storage site on the Goshute Indian reservation in Utah. The state of Utah opposed the effort and although the Private Fuel Storage site received a license in 2006, operations never began there because of ongoing legal battles and land use issues. A spokesperson for the State of Utah stated that if the owners and generators renewed their efforts to begin operations at Private Fuel Storage, Utah would continue to fight the effort. Furthermore, in 2014, the Western Governors Association—an association representing 19 western states—passed a resolution stating that the Governor of a state must agree in writing if an interim storage site for spent nuclear fuel is to be considered in the state. Experts and stakeholders we spoke with reiterated this position, stating that states, and many local communities, are concerned that a consolidated interim storage site could become a de facto permanent storage site.

In 2011, we reported that no nation had ever succeeded in building a permanent repository for spent nuclear fuel, in part due to societal concerns, and that there was no model or set of lessons that would guarantee success in such a complex, decades-long endeavor.³¹ Based on our discussions with experts and stakeholders and a review of relevant documents on spent nuclear fuel management, those same societal concerns apply to building a consolidated interim storage facility. However, as we reported in 2011, efforts to site and commence operations at the Waste Isolation Pilot Plant in New Mexico succeeded largely because a contractor addressed public opposition to the facility.

³¹[GAO-11-229](#).

Experts and Stakeholders
Said Coordinated Outreach
May Help Achieve and
Sustain Public Acceptance

Specifically, the contractor involved local communities situated along the transportation routes throughout the state, providing education and training programs and equipment related to the safe transportation of radioactive waste.³² The project might have ended because of state opposition if DOE had not conceded some oversight authority to the state.

In our discussions with experts and stakeholders, one common theme was apparent: public acceptance cannot be achieved without a coordinated outreach strategy, which would include components such as transparent transportation planning, and a defined consent-based process. According to these experts and stakeholders, a coordinated outreach strategy could include, among other things, sharing information with specific stakeholders and the general public about DOE's ongoing activities related to managing spent nuclear fuel. The experts and stakeholders said that DOE has no coordinated outreach strategy, which DOE officials confirmed. A coordinated outreach strategy would be an important aspect of informing the public about spent nuclear fuel management plans and DOE's current management efforts irrespective of which path Congress agrees upon.

DOE officials confirmed that they do not have a coordinated outreach strategy for communicating with specific stakeholders and the general public about their activities related to spent nuclear fuel management. Instead, DOE officials said they communicate regularly with certain stakeholders. For example, DOE officials told us that they actively obtain the input of state and tribal representatives on spent nuclear fuel transportation-planning issues. In addition, DOE officials told us they plan to continue to participate in meetings with technical experts and industry stakeholders and to post information online. For example, DOE officials made several presentations on issues related to storage, transportation, and disposal at the Nuclear Waste Technical Review Board's meeting in November 2013. Some experts we spoke with were critical of DOE efforts to involve stakeholders. For example, experts who represent multi-state, regional organizations active in spent-nuclear-fuel transportation planning said DOE has not been transparent or effective in its communication with stakeholders. Furthermore, although DOE had issued fact sheets related to spent nuclear fuel management related to work on Yucca Mountain, DOE has not recently developed spent nuclear fuel information for the

³²[GAO-11-229](#).

general public, such as a fact sheet explaining issues related to transporting spent nuclear fuel, nor does DOE have plans to do so in the upcoming fiscal year. DOE officials said that recently they have stepped up their outreach efforts with stakeholders. For example, in April 2014, DOE completed a Draft National Transportation Plan for moving spent nuclear fuel.

In terms of DOE's efforts to inform specific stakeholders and the general public about spent nuclear fuel issues by posting information online, DOE has two websites devoted to spent nuclear fuel issues. However, we found that the information on those sites either does not provide information about the agency's ongoing activities or is not easily accessible.³³ DOE also has an online library where it has posted selected technical studies;³⁴ however, the agency has done little to explain how it plans to use these studies. DOE officials acknowledged that they could better explain the studies posted. They indicated that it is premature to conduct more extensive public outreach until the timing and logistics of transporting spent nuclear fuel have been determined. Experts from multi-state organizations disagree, stating that if DOE does not engage the public soon, then DOE could appear to be unilaterally making decisions without considering public input.

According to experts from industry and an entity representing state regulatory agencies, DOE officials have not defined a consent-based process or engaged interested communities in discussions on hosting a consolidated interim storage facility. An expert from an entity representing

³³One website is for DOE's Nuclear Fuels Storage and Transportation Planning Project that among other things, plans for and implements the agency's activities related to the transportation and storage aspects of its strategy and lists four documents: (1) the Blue Ribbon Commission on America's Nuclear Future Report to the Secretary of Energy, (2) DOE's *Strategy for the Management and Disposal of Used Nuclear Fuel and High-Level Radioactive Waste*, (3) DOE's *Preliminary Evaluation of Removing Used Nuclear Fuel From Shutdown Sites, and Public Preferences Related to Consent-Based Siting of Radioactive Waste Management Facilities for Storage and Disposal*. The website is available at <http://energy.gov/ne/fuel-cycle-technologies/nuclear-fuels-storage-transportation-planning-project>. The other website—known as the Centralized Used Fuel Resource for Information Exchange website—was launched in March 2013 and shares documents and data about the storage, transportation, and disposal of spent nuclear fuel. However, as of July 2014, the website is not readily accessible from DOE's website and must be found using public search engines, such as Google. This second website is available at <http://curie.ornl.gov>.

³⁴The library can be found at <http://energy.gov/ne/listings/document-library>.

state regulatory agencies said that in order to consent, potential host communities need to know what consent entails, both in the short and long term, including the perceived risks and benefits and the planned duration and proposed capacity of the facility before any decisions can be made. Furthermore, a few experts told us that they had heard of some community representatives who approached DOE to express their interest in hosting a storage facility, but DOE did not engage in substantive discussions with them. DOE has requested funding in its fiscal year 2014 and 2015 budget requests to plan for consent-based siting, but DOE officials said they had not developed a formal siting process for an interim storage facility.

A 2013 report by the University of Oklahoma, in collaboration with Sandia National Laboratory, documented the importance of social media,³⁵ such as Twitter postings and Google searches, as public attention to both nuclear energy and nuclear waste management spiked immediately after the earthquake and tsunami struck the Fukushima Daiichi nuclear power plant complex in Japan on March 11, 2011, causing widespread concern of a potential release of radiation.³⁶ Furthermore, according to experts and stakeholders, social media have been used effectively to provide information to the public through coordinated outreach efforts by organizations with an interest in spent nuclear fuel policy. Some of these organizations oppose DOE's strategy and the information they distribute reflects their position. In the absence of a coordinated outreach strategy by DOE, including social media, DOE does not effectively provide a forum to share information and offer greater transparency. DOE promotes the use of social media platforms to engage in open discussions about energy issues, but has posted only a few reports and descriptions of spent nuclear fuel management on its web page.

³⁵Prepared for DOE, Nuclear Fuel Storage and Transportation Planning Project, *Public Preferences Related to Consent-Based Siting of Radioactive Waste Management Facilities for Storage and Disposal: Analyzing Variations over Time, Events, and Program Designs*; (February 2013).

³⁶As reported by the Institute of Nuclear Power Operations (Institute of Nuclear Power Operations, *Special Report on the Nuclear Accident at the Fukushima Daiichi Nuclear Power Station* (Atlanta, GA: November 2011), Tokyo Electric Power Company personnel determined that water levels in the spent fuel pool at Fukushima Daiichi did not drop below the top of the fuel. An NRC order noted that during the Fukushima event, there was concern that the spent fuel was overheating, and the concern persisted primarily because of a lack of readily available and reliable information on water levels in spent fuel pools.

Experts and stakeholders suggested that it would be beneficial for DOE to begin developing a plan and materials for communicating with the specific stakeholders and the general public about the benefits and concerns with issues related to moving and storing spent nuclear fuel. An expert from a multi-state organization added a particular focus should be on the communities, including elected officials, living near shutdown sites. Such communication would be consistent with the Office of Management and Budget's Open Government Directive, which directs agencies to create and institutionalize a culture of transparency, participation, and collaboration in order to create a more open government.³⁷ Furthermore, as we reported previously in 2011 on lessons learned from spent nuclear fuel management,³⁸ we found that transparency and cooperation are important in overcoming opposition to spent nuclear fuel storage. Without greater transparency and a coordinated outreach program, specific stakeholders and the general public may not have confidence in DOE's efforts to manage spent nuclear fuel and may continue to distrust DOE.

Conclusions

DOE has made efforts to share information about its ongoing spent nuclear fuel management activities by presenting at technical meetings and posting information on its website. Sharing information is made more difficult for DOE by uncertainties about the future path of spent nuclear fuel management. DOE intends for its strategy to provide an initial basis for discussions on a sustainable path forward. Until the federal government proceeds with a new policy to meet its contractual obligations, the federal liability for litigation related to spent nuclear fuel management will continue to grow. Our analysis of expert and stakeholders comments indicates four types of challenges to implementing DOE's January 2013 strategy to manage spent nuclear fuel within the time frames projected. DOE has begun to address aspects of these challenges, but the challenges cannot be fully addressed until uncertainties regarding a path forward are resolved. The societal challenge of building and sustaining public acceptance of the federal government's spent nuclear fuel management activities, however, will need to be addressed irrespective of the path the federal government

³⁷Office of Management and Budget, Memorandum for the Heads of Executive Departments and Agencies, Open Government Directive (Washington, D.C.: Dec. 8, 2009).

³⁸[GAO-11-229](#).

agrees upon. Unless and until there is a broad understanding of the issues associated with transporting spent nuclear fuel and managing it at consolidated facilities, specific stakeholders and the general public may be unlikely to support any spent nuclear fuel management program that is decided on in the future. According to experts and stakeholders, organizations that oppose DOE's strategy have reached the public by effectively using social media to promote their positions. In contrast, DOE currently has no coordinated outreach strategy. In the absence of a coordinated outreach strategy by DOE, specific stakeholders and the general public may not have complete and accurate information about the agency's activities, making it more difficult for the federal government to move forward with any policy to manage spent nuclear fuel and address federal liability.

Recommendation for Executive Action

To help achieve and sustain public acceptance for future spent nuclear-fuel management efforts, the Secretary of the Department of Energy should develop and implement a coordinated outreach strategy for providing information to specific stakeholders and the general public on federal activities related to managing spent nuclear fuel.

Agency Comments

We provided DOE with a draft of this report for review and comment. In written comments, which are reproduced in appendix VI, DOE generally agreed with our findings and the recommendation in our report. DOE said that it plans to continue to engage states, tribes, and other stakeholders regarding planning for future transportation of spent nuclear fuel and that it would improve its outreach to the general public. DOE also said it would make an effort to provide the public with more complete information about its ongoing activities and the issues associated with spent fuel management. DOE also provided technical comments, which we incorporated as appropriate.

As agreed with your offices, unless you publicly announce the contents of this report earlier, we plan no further distribution until 30 days from the report date. At that time, we will send copies to the appropriate congressional committees, the Secretary of Energy, the Administrator of the Environmental Protection Agency, the Attorney General, the Chairman of the Nuclear Regulatory Commission, the Secretary of Transportation, and other interested parties. In addition, the report will be available at no charge on the GAO website at <http://www.gao.gov>.

If you or your staff members have any questions about this report, please contact me at (202) 512-3841 or ruscof@gao.gov. Contact points for our Offices of Congressional Relations and Public Affairs may be found on the last page of this report. Key contributors to this report are listed in appendix VII.

A handwritten signature in black ink that reads "Frank Rusco". The signature is written in a cursive style with a long, sweeping horizontal line extending to the right from the end of the name.

Frank Rusco
Director
Natural Resources and Environment

Appendix I: Objectives, Scope, and Methodology

To describe the expected rate of spent nuclear fuel accumulation in wet and dry storage, we obtained data from the Nuclear Energy Institute, an industry policy umbrella organization. These data included information on the amounts of spent nuclear fuel currently in wet and dry storage and projected amounts of spent nuclear fuel to be added to the current wet and dry storage inventory as it is removed from a reactor until it is permanently shut down. We updated the data as necessary to account for, among other things, reactors shutting down early. In describing the rate at which spent nuclear fuel accumulates, we assumed that except for the few reactors that have announced early permanent shutdown dates, the nation's current reactors continue to operate through a 20-year extended license period and continue to produce spent nuclear fuel at the same rate; that no new reactors are brought online, and that the generation of spent nuclear fuel declines as reactors shut down. To ensure the accuracy of our estimates, we provided selected sections of the draft report to representatives from the Nuclear Energy Institute for their review and comment. We incorporated their comments, as appropriate, in the final report.

To identify the basis of federal liability for spent nuclear fuel management to date and of DOE's estimate of future liabilities, we reviewed documents from the Departments of Energy (DOE) and Justice. These documents included a generic Department of Justice settlement agreement, DOE's annual memorandums that described the liability estimate, and DOE's annual financial reports that include the figures on the cumulative amounts paid to settle with utilities for DOE's inability to accept spent nuclear fuel for disposal and the estimated remaining liability. In addition, we interviewed officials from DOE and the Department of Justice. We also relied on our prior work ([GAO-10-48](#)) to provide information on the typical costs that may contribute to the federal government's future liabilities. To ensure that we had complete and accurate information on these costs, we provided selected sections of the draft report to representatives from the Nuclear Energy Institute for their review and comment. We incorporated their comments, as appropriate, in the final report.

To assess the challenges, if any, that experts and stakeholders have identified to the federal government's ability to meet DOE's time frames for managing spent nuclear fuel at consolidated interim storage facilities and potential ways for DOE to mitigate the challenges, we identified individuals with spent nuclear fuel management experience and expertise. In our prior work ([GAO-10-48](#)), we had already identified experts in spent nuclear fuel management. Starting with this group and

using a snowballing technique, we asked experts about their own expertise and also asked each expert or stakeholder to recommend other individuals that we might consider including in our discussions. We determined that we had a sufficient sample of relevant experts and stakeholders when the names of experts and stakeholders recommended to us became repetitive and when we determined that we had a balanced set of viewpoints represented. In total, we interviewed over 90 individuals, including federal officials, who represented a wide range of viewpoints and expertise. However, our selection of experts is nongeneralizable, in that opinions cannot be generalized to other experts or tallied, either within or across types of expertise.

Once identified, we contacted the individuals and confirmed their familiarity with the issues. Before we began each interview, we asked the individual to provide information on his or her background, including education, employment history, and experiences related to spent nuclear fuel management to assess their level of expertise. In addition, we asked all interview participants to self-assess their expertise in various aspects of spent nuclear fuel management such as the political, technological, and regulatory issues related to spent nuclear fuel management. Using our professional judgment, we assessed the level of expertise for each individual in the different issues we considered in our analysis. Opinions of experts on a topic outside their own area of expertise are sometimes presented as the opinions of “stakeholders.” In some cases, the same individual might be considered an expert in one specific issue, but a stakeholder on another issue.

Generally, the experts and stakeholders represented their organization’s views. The experts and stakeholders we consulted included:

- DOE in headquarters, field offices, and scientists from several national laboratories, including Argonne National Laboratory, Oak Ridge National Laboratory, Pacific Northwest National Laboratory, and Sandia National Laboratories;
- officials from other federal agencies and organizations involved with spent nuclear fuel management activities, including the Department of Navy, the Nuclear Regulatory Commission, and the Nuclear Waste Technical Review Board;
- state, local, and regional governments or organizations, including the states of Nevada, Texas, and Utah; the State of Minnesota Public Utilities Commission; Eddy County, New Mexico; and Nye County, Nevada; Council of State Governments, Eastern Regional

Conference; National Association of Regulatory Utility Commissioners; the National Conference of State Legislatures; Southern States Energy Board; The Council of State Governments, Midwestern Office; Western Governors' Association; Western Interstate Energy Board;

- industry: including AHL Consulting; AREVA; Association of American Railroads; Chicago Bridge & Iron; Dairyland Power Cooperative; Dominion; Duke Energy; Energy Resources International, Inc.; Energy Solutions, Inc.; Exelon Corporation; Kouts Consulting; L. Barrett Consulting; Nuclear Energy Institute; Nuclear Waste Strategy Coalition; Pillsbury Winthrop Shaw Pittman LLP; PSEG Nuclear, LLC; Tennessee Valley Authority; The Brattle Group; Governmental Strategies, Inc.; The Yankee Nuclear Power Companies: Yankee Atomic, Connecticut Yankee, and Maine Yankee; Van Ness Feldman LLP; and Xcel Energy;
- representatives from a range of interest groups, including Beyond Nuclear, Institute for Energy and Environmental Research, Natural Resources Defense Council, Nuclear Information and Resource Service, Southwest Research and Information Center, Union of Concerned Scientists, U.S. Chamber of Commerce – Institute for 21st Century Energy; and
- independent entities, including Black Mountain Research; Carnegie Institution for Science; Kadak Associates; Leroy Law Office; National Research Council, National Academy of Sciences; TA Frazier LLC; and University of Oklahoma.

To ensure we asked consistent questions among all the identified experts and stakeholders, we developed a data collection instrument that included broad questions related to the challenges, if any, to the federal government's ability to meet DOE's time frames for accepting spent nuclear fuel at consolidated interim storage facilities. We pre-tested the instrument with a few individual experts and stakeholders to ensure that our questions were clear and would provide us with the information that we needed. After each pretest, we refined the instrument, accordingly. We analyzed the interviews to identify consistent themes and issues that emerged. See appendix II for a list of the experts and stakeholders whom we interviewed and their affiliations.

In addition to the interviews, we reviewed relevant documents, such as DOE's January 2013 strategy for the management and disposal of used nuclear fuel and high level waste and the January 2012 Blue Ribbon Commission on America's Nuclear Future's report to the Secretary of

Energy. We also reviewed documents prepared by the organizations that we interviewed and attended conferences sponsored by relevant organizations, including

- the U.S. Nuclear Waste Technical Review Board's Technical Workshop on the Impacts of Dry Storage Canister Designs on the Future Handling, Storage, Transportation, and Geologic Disposal of Spent Nuclear Fuel in the United States;
- the Nuclear Energy Institute's Used Fuel Management Conference; and
- the Bipartisan Policy Center's regional meeting of Identifying a Path Forward on America's Nuclear Waste.

We also interviewed officials from the Department of Transportation and the Environmental Protection Agency. According to officials from these agencies, each agency has a specified role with respect to regulating transportation and interim storage of spent nuclear fuel. According to Department of Transportation officials, the agency coordinates and shares responsibility with the NRC on issues related to transporting spent nuclear fuel as stipulated in a memorandum of understanding between the two agencies. According to Environmental Protection Agency officials, the agency has a regulatory framework in place for storage of spent nuclear fuel that will allow NRC to license interim storage facilities.

We conducted this performance audit from November 2013 to October 2014, in accordance with generally accepted government auditing standards. Those standards require that we plan and perform the audit to obtain sufficient, appropriate evidence to provide a reasonable basis for our findings and conclusions based on our audit objectives. We believe that the evidence obtained provides a reasonable basis for our findings and conclusions based on our audit objectives.

Appendix II: Spent Nuclear Fuel Experts and Stakeholders We Interviewed

Name	Affiliation
1. Lake Barrett	L. Barrett Consulting
2. Evaristo J. (Tito) Bonano	Sandia National Laboratories
3. David Boyd	State of Minnesota Public Utilities Commission
4. William Boyle	Department of Energy
5. Tom Brookmire	Dominion
6. John Butler	Nuclear Energy Institute
7. Robert (Bob) Capstick	The Yankee Nuclear Power Companies: Yankee Atomic, Connecticut Yankee, and Maine Yankee
8. Jack Clemmens	Chicago Bridge & Iron
9. Pamela Cowan	Exelon Corporation
10. Susan Crockett	Eddy County, New Mexico
11. Martha Crosland	Department of Energy
12. Kevin Crowley	National Research Council, National Academy of Sciences
13. Matthew (Matt) Crozat	Department of Energy
14. Kris Cummings	Nuclear Energy Institute
15. Peter Davies	Sandia National Laboratories
16. Alan Denko	Department of Navy
17. Fred Dilger	Black Mountain Research
18. Geoffrey (Geoff) Fettus	Natural Resources Defense Council
19. Tim Frazier	TA Frazier LLC
20. Derrick Freeman	Nuclear Energy Institute
21. Bob Fronczak	Association of American Railroads
22. James George	Department of Energy
23. John Gercy	Dominion
24. Mariko Geronimo	The Brattle Group
25. Ellen Ginsberg	Nuclear Energy Institute
26. Frank Graves	The Brattle Group
27. Christopher Guith	U.S. Chamber of Commerce – Institute for 21st Century Energy
28. Kuhika Gupta	University of Oklahoma
29. Brian Gustems	PSEG Nuclear, LLC
30. Robert Halstead	State of Nevada
31. Don Hancock	Southwest Research and Information Center
32. Brady Hanson	Pacific Northwest National Laboratory
33. Christopher (Chris) Hanson	Department of Energy
34. Scott Hendrick	National Conference of State Legislatures
35. Nate Hickman	State of Texas
36. Brian Holian	Nuclear Regulatory Commission

Appendix II: Spent Nuclear Fuel Experts and Stakeholders We Interviewed

Name	Affiliation
37. Rob Howard	Oak Ridge National Laboratory
38. Lisa Janairo	The Council of State Governments, Midwestern Office
39. Josh Jarrell	Oak Ridge National Laboratory
40. Hank Jenkins-Smith	University of Oklahoma
41. Bradley Jones	Nuclear Regulatory Commission
42. Steve Jones	Nuclear Regulatory Commission
43. Andrew Kadak	Kadak Associates
44. Kevin Kamps	Beyond Nuclear
45. Christopher Kouts	Kouts Consulting
46. Darrell Lacy	Nye County, Nevada
47. Doug Larson	Western Interstate Energy Board
48. Ned Larson	Department of Energy
49. David Leroy	Leroy Law Office
50. Adam Levin	AHL Consulting
51. Mark Lombard	Nuclear Regulatory Commission
52. Edwin Lyman	Union of Concerned Scientists
53. Arjun Makhijani	Institute for Energy and Environmental Research
54. Zita Martin	Tennessee Valley Authority
55. Ben McRae	Department of Energy
56. Rodney (Rod) McCullum	Nuclear Energy Institute
57. Katrina McMurrian	Nuclear Waste Strategy Coalition
58. Richard Meserve	Carnegie Institution for Science
59. Mike Morrissey	State of Texas
60. Nigel Mote	Nuclear Waste Technical Review Board
61. Paul Murray	AREVA
62. Connie Nakahara	State of Utah
63. Steve Nesbit	Duke Energy
64. Cyrus Nezhad	Department of Energy
65. Robert Nordhaus	Van Ness Feldman LLP
66. Mark Nutt	Argonne National Laboratory
67. Brian O'Connell ^a	National Association of Regulatory Utility Commissioners
68. Mary Olson	Nuclear Information and Resource Service
69. Rob Palmberg	Dairyland Power Cooperative
70. Aaron Perea	Department of Energy
71. Christopher (Chris) Phillips	Energy Solutions, Inc.
72. Terry Pickens	Xcel Energy
73. Lara Pierpoint	Department of Energy

Appendix II: Spent Nuclear Fuel Experts and Stakeholders We Interviewed

Name	Affiliation
74. Everett Redmond	Nuclear Energy Institute
75. James Rubenstone	Nuclear Regulatory Commission
76. Chris Scolari	Western Governors' Association
77. Jay Silberg	Pillsbury Winthrop Shaw Pittman LLP
78. Tim Smith	Governmental Strategies, Inc.
79. Norman St. Amour	Nuclear Regulatory Commission
80. Eileen Supko	Energy Resources International, Inc.
81. Peter Swift	Sandia National Laboratories
82. Sheiba Tafazzoli	Nuclear Regulatory Commission
83. Jane Kelley Taylor	Department of Energy
84. Leigh Trocine	Nuclear Regulatory Commission
85. Uldis Vanags	Council of State Governments, Eastern Regional Conference
86. Jack Volpato	Eddy County, New Mexico
87. John Wagner	Oak Ridge National Laboratory
88. Sandra Wastler	Nuclear Regulatory Commission
89. Christopher Wells	Southern States Energy Board
90. Jim Wiggins	Nuclear Regulatory Commission
91. Jeffrey (Jeff) Williams	Department of Energy
92. Jim Williams	Western Interstate Energy Board
93. David (Dave) Zabransky	Department of Energy

Source: GAO. | GAO-15-141

^aBrian O'Connell retired in 2013 as director of the Nuclear Waste Program.

Appendix III: Commercial Spent Nuclear Fuel Stored in Wet, Dry, and Shutdown Storage Sites (Text for Interactive Figure 5)

Wet storage sites

1. Beaver Valley
2. Callaway
3. Clinton
4. Fermi
5. Shearon Harris
6. Pilgrim
7. South Texas Project
8. Virgil C. Summer
9. Three Mile Island
10. Watts Bar
11. Wolf Creek
12. GE Morris

Wet and dry storage sites

1. Arkansas Nuclear One
2. Braidwood
3. Browns Ferry
4. Brunswick
5. Byron
6. Calvert Cliffs
7. Catawba
8. Columbia Generating Station
9. Comanche Peak
10. Cooper
11. Davis-Besse
12. Diablo Canyon
13. Donald C. Cook
14. Dresden
15. Duane Arnold
16. Joseph M. Farley
17. James A. FitzPatrick
18. Fort Calhoun
19. R.E. Ginna
20. Grand Gulf
21. Edwin I. Hatch
22. Hope Creek
23. Indian Point
24. La Salle
25. Limerick
26. McGuire
27. Millstone

**Appendix III: Commercial Spent Nuclear Fuel
Stored in Wet, Dry, and Shutdown Storage
Sites (Text for Interactive Figure 5)**

28. Monticello
29. Nine Mile Point
30. North Anna
31. Oconee
32. Oyster Creek
33. Palisades
34. Palo Verde
35. Peach Bottom
36. Perry
37. Point Beach
38. Prairie Island
39. Quad Cities
40. River Bend
41. H. B. Robinson
42. St. Lucie
43. Salem
44. Seabrook
45. Sequoyah
46. Surry
47. Susquehanna
48. Turkey Point
49. Vermont Yankee
50. Vogtle
51. Waterford

Shut-down storage sites^a

1. Big Rock Point
2. Maine Yankee
3. Yankee Rowe
4. Haddam Neck
5. Crystal River
6. Kewaunee
7. La Crosse
8. Zion
9. Trojan
10. Humboldt Bay
11. Rancho Seco
12. San Onofre

33 states with accumulated spent fuel

1. Alabama
2. Arizona
3. Arkansas

**Appendix III: Commercial Spent Nuclear Fuel
Stored in Wet, Dry, and Shutdown Storage
Sites (Text for Interactive Figure 5)**

4. California
5. Connecticut
6. Florida
7. Georgia
8. Illinois
9. Iowa
10. Kansas
11. Louisiana
12. Maine
13. Maryland
14. Massachusetts
15. Michigan
16. Minnesota
17. Mississippi
18. Missouri
19. Nebraska
20. New Hampshire
21. New Jersey
22. New York
23. North Carolina
24. Ohio
25. Oregon
26. Pennsylvania
27. South Carolina
28. Tennessee
29. Texas
30. Vermont
31. Virginia
32. Washington
33. Wisconsin

Source: GAO analysis of NRC and DOE data, as of July 2014. | GAO-15-141

^aIn addition, there are three permanently shutdown reactors at sites that continue to have operating reactors. The sites that have both shutdown and operating reactors include the Dresden, Indian Point, and Millstone sites. Of the 12 shutdown reactor sites, the Zion site has two permanently shutdown reactors and the San Onofre site has three permanently shutdown reactors. Also, the operator at the Vermont Yankee site has announced that it plans to shut down the reactor at the end of 2014.

Appendix IV: Additional Information on the Spent Nuclear Fuel Settlement Agreements

The settlement agreements between the Department of Justice and the owners or generators of spent nuclear fuel have not been identical and have changed over time. For example, from 2004 through 2009, the Department of Justice settled with six owners and generators representing 40 of the 118 reactors covered under the standard contract. Under the settlement agreements—known as the Exelon Settlement agreements—it was assumed that the Department of Energy (DOE) would have accepted spent nuclear fuel for disposal at a rate of 900 metric tons per year from 1998 through 2014, and at a rate of 2,100 metric tons per year thereafter. Under the Exelon Settlement agreements, DOE is liable for spent nuclear fuel storage costs that owners and generators would not have incurred if DOE had accepted and disposed of the fuel at this rate. Beginning in 2011, the Department of Justice began using a new settlement agreement—called the New Framework Settlement agreement. As of September 8, 2014, the Department of Justice reported that it has executed New Framework Settlement Agreements with 20 litigants representing 45 reactors covered under the standard contract. These settlement agreements do not supersede the Exelon agreements, which remain effective for the parties that settled through 2009. The New Framework Settlement agreements assumed a higher rate of acceptance of spent nuclear fuel, based on an appellate decision. Specifically, the new settlement agreements assumed that DOE would have accepted spent nuclear fuel for disposal at a rate of 1,200 metric tons per year from 1998 through 2002; 2,000 metric tons in 2003; 2,650 metric tons per year from 2004 through 2007; and 3,000 metric tons per year beginning in 2008. The result is that some types of spent nuclear fuel storage costs for which owners and generators were deemed responsible under the Exelon Settlement agreement are now a DOE liability under the new settlement agreements.¹

According to a Department of Justice document used to discuss settlements for the owners and generators covered by the New Framework Settlement agreements, there are five categories of reimbursable costs:

¹The Department of Justice has also entered into four other settlement agreements with former owners of spent nuclear fuel who have since exited the industry. While there is no pending litigation concerning the settled claims, litigation continues with the new owners of the reactors in three of these cases.

1. **Additional Pool Storage:** Costs to purchase, license, and install new, additional, or replacement storage racks or to make available additional storage spaces to the extent, and only to the extent, necessary to provide additional capacity in the spent nuclear fuel pool at the site.
2. **Dry Storage Costs:** Costs to purchase canisters and casks, including canisters that may be licensed for transport and casks for transferring spent nuclear fuel to the dry storage facility;² costs to load spent nuclear fuel into and to transport canisters and casks to the dry storage facility; costs of ancillary equipment for casks and cask loading, such as crawler-type transporters, dollies, and vacuum-drying equipment; costs to conduct initial loading demonstrations required by the Nuclear Regulatory Commission (NRC); costs for training and development of procedures; costs for cask-loading campaign mobilization and demobilization; costs to study and to evaluate spent nuclear fuel storage options; costs for quality assurance inspections of cask vendors; costs for security improvements required by NRC for the dry storage facility; costs of maintaining and operating the dry storage facility; costs for security improvements or upgrades required to comply with utility's security plan approved by the NRC; and costs to design, license and build the dry storage facility, including costs of building the portion of the facility that will be required for the dry storage of the utility's spent nuclear fuel in addition to utility's allocations, provided that the utility can demonstrate that it was more cost effective to incur the costs to design, license and build the dry storage facility during the claim period rather than after termination of the agreement. If the utility previously constructed a dry storage facility for reasons other than to store the utility's allocations or needs to place, or places, items other than canisters or casks containing the utility's allocations in dry storage, only the costs attributable to the portion of the dry storage facility needed to store the utility's allocations will be allowable.
3. **Modifications of the Existing Plant:** Costs paid to modify cranes to the extent, and only to the extent, necessary to increase the rated lifting capacity of the crane(s) used in the loading of spent nuclear fuel from the fuel storage pool, provided that the utility can establish that these modifications would not have been necessary to meet the requirements of NUREG-0612 or load spent nuclear fuel in casks or

²The dry storage facility is known as the independent spent fuel storage installation.

canisters provided by DOE had DOE begun performance in 1998; building modifications that the utility can establish would not have been necessary to load spent nuclear fuel into casks or canisters provided by DOE (e.g., seismic restraints for fuel pool or upgrades to floor of cask-loading area); and costs to improve the haul path from the fuel building to the dry storage facility, to the extent that the haul path is different from the path that the utility would have used to deliver fuel to DOE. If the utility incurs costs for site modifications or equipment purchases to store the utility's allocations that otherwise benefit the operation of the plant, including crane modifications for purposes other than loading storage canisters or casks, the cost reimbursed will be proportional to the benefit to the operation of the plant.

4. **Property Taxes:** Costs paid as a result of any increase in assessed property tax resulting from and traceable to projects, as identified in the preceding three paragraphs, that were undertaken to provide additional storage for the utility's allocations.
5. **Labor and Overhead:** The cost of labor charged directly by the utility's employees to any project that is otherwise allowable shall be considered allowable, provided that the hours expended on such project are charged in accordance with utility's standard time recordation system and are identified at the individual employee level. In addition, the following types of overhead charges will be deemed allowable provided that the charges are calculated in accordance with the utility's established accounting practice and policy: (a) payroll overheads or "burdens" associated with labor hours charged to allowable projects and (b) non-payroll overheads allocated to allowable projects claimed up to a maximum of 5 percent of the portion of the utility's claim which is otherwise allowable and to which such non-payroll overheads are allocated.

Appendix V: Process and Costs of Transferring Spent Nuclear Fuel from Wet to Dry Storage (Text for Interactive Figure 7)

1. Nuclear power reactor and spent nuclear fuel pools	<p>Nuclear power reactor and spent nuclear fuel pools—Spent nuclear fuel typically cools for at least 5 years in a pool before a canister (\$700,000 to \$1.5 million) is placed in the pool, filled with spent nuclear fuel, removed from the pool, and dried. A reusable steel transfer cask (\$1.5 million to \$3 million) provides shielding for nearby workers as the spent nuclear fuel is transferred from the pool and placed into either a vertical or horizontal dry storage system. The process of transferring spent nuclear fuel, excluding the canister, transfer cask, and storage system costs \$150,000 to \$550,000. Then the canister is placed into either a vertical or horizontal dry storage system.</p>
2. Transporter	<p>Transporter— For vertical storage, a crawler-type transporter (\$1 million to \$1.5 million) carries the entire canister and storage cask in a vertical orientation to a storage pad. For horizontal storage, a tractor with a transfer trailer carries the canister in a reusable transfer cask in a horizontal orientation (\$1.5 million to \$3 million) to the horizontal module.</p>
3. Vertical storage cask/horizontal storage module	<p>Vertical storage cask/horizontal storage module—Utilities typically choose either a vertical storage system (\$250,000 to \$350,000 per cask) or a horizontal storage system (\$500,000 to \$600,000 per module) for a particular site.</p>
4. Safety and security systems and annual operations	<p>Safety and security systems and annual operations—Design, licensing, and construction of the dry storage facility and safety and security systems (\$5.5 million to \$42 million). Annual operations include costs of security, operations, and maintenance cost. Annual operations at an operating reactor site: \$100,000 to \$300,000 and at a shutdown reactor site: \$2.5 million to \$6.5 million.</p>

Source: GAO analysis of Nuclear Energy Institute data. | GAO-15-141.

Appendix VI: Comments from the Department of Energy



Department of Energy
Washington, DC 20585

September 26, 2014

Mr. Frank Rusco
Director, Natural Resources
and Environment
U.S. Government Accountability Office
441 G Street, NW
Washington, D.C. 20548

Dear Mr. Rusco:

Thank you for providing a draft copy of the Government Accountability Office (GAO) report, "Spent Nuclear Fuel Management: Outreach Needed to Help Gain Public Acceptance for Federal Activities that Address Liability," (GAO-14-715). We have reviewed the draft report and provide general comments below.

GAO was charged by the Chairman of the House Energy and Commerce Committee and the Chairman of the Environment and the Economy Subcommittee of the House Energy and Commerce Committee to determine: (1) at what rate is spent nuclear fuel accumulating and how do the components of spent nuclear fuel management contribute to federal liabilities; (2) what factors, if any, might affect DOE's ability to meet its time frames to begin taking custody of spent nuclear fuel at interim storage facilities; (3) how might delays, if any, in DOE's taking custody of spent nuclear fuel at interim storage facilities affect future federal liabilities. We recognize that conducting a review of the Department's spent nuclear fuel activities and federal liabilities is a difficult undertaking, and we appreciate the time and thoroughness GAO took during its review.

The Department has the following comments regarding the draft report's recommendation.

Recommendation: To help achieve and sustain public acceptance for future spent nuclear fuel management efforts, the Secretary of the Department of Energy should develop and implement a coordinated outreach strategy for providing information to specific stakeholders and the general public on federal activities related to managing spent nuclear fuel.

The Department agrees that effective and coordinated outreach and communication to affected stakeholders and the general public will be critical to help achieve and sustain public acceptance of future spent nuclear fuel management efforts



Printed with soy ink on recycled paper

Currently the Department is actively engaged with States, Tribes and other stakeholders in planning for future transportation of spent nuclear fuel. The Department plans to

continue these interactions and improve its outreach to the general public. It will also make an effort to provide the public with more complete information about its ongoing activities and the issues associated with spent fuel management.

Additionally, the Department requests that GAO address the following factual inaccuracies in the draft report:

- The report implies (on pages 15 and 19) that there are technical challenges and uncertainties with the transportation of all spent nuclear fuel, which is not true. There are in fact such challenges and uncertainties with respect to *some* spent nuclear fuel. The overly broad statements should be so qualified.
- On page 19, the report incorrectly states that high burn-up fuel has only recently been used. In fact, high burn-up fuel has been used for more than 20 years.

Thank you for the opportunity to provide comments on this draft. We look forward to receiving your final report. If you have any questions related to this letter, please feel free to contact Mr. John Herczeg at (202) 586-3715.

Sincerely,

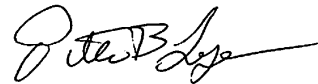

Peter B. Lyons,
Assistant Secretary,
for Nuclear Energy

Appendix VII: GAO Contact and Staff Acknowledgments

GAO Contact

Frank Rusco, (202) 512-3841 or ruscof@gao.gov

Staff Acknowledgments

In addition to the individual named above, Karla Springer (Assistant Director), Arkelga Braxton, Kevin Bray, Ross Gauthier, Diana C. Goody, Armetha Liles, Wendell Matt, Mehrzad Nadji, Cynthia Norris, Katrina Pekar-Carpenter, Timothy Persons (Chief Scientist), Anne Rhodes-Kline, and Robert Sánchez made key contributions.

GAO's Mission

The Government Accountability Office, the audit, evaluation, and investigative arm of Congress, exists to support Congress in meeting its constitutional responsibilities and to help improve the performance and accountability of the federal government for the American people. GAO examines the use of public funds; evaluates federal programs and policies; and provides analyses, recommendations, and other assistance to help Congress make informed oversight, policy, and funding decisions. GAO's commitment to good government is reflected in its core values of accountability, integrity, and reliability.

Obtaining Copies of GAO Reports and Testimony

The fastest and easiest way to obtain copies of GAO documents at no cost is through GAO's website (<http://www.gao.gov>). Each weekday afternoon, GAO posts on its website newly released reports, testimony, and correspondence. To have GAO e-mail you a list of newly posted products, go to <http://www.gao.gov> and select "E-mail Updates."

Order by Phone

The price of each GAO publication reflects GAO's actual cost of production and distribution and depends on the number of pages in the publication and whether the publication is printed in color or black and white. Pricing and ordering information is posted on GAO's website, <http://www.gao.gov/ordering.htm>.

Place orders by calling (202) 512-6000, toll free (866) 801-7077, or TDD (202) 512-2537.

Orders may be paid for using American Express, Discover Card, MasterCard, Visa, check, or money order. Call for additional information.

Connect with GAO

Connect with GAO on [Facebook](#), [Flickr](#), [Twitter](#), and [YouTube](#). Subscribe to our [RSS Feeds](#) or [E-mail Updates](#). Listen to our [Podcasts](#). Visit GAO on the web at www.gao.gov.

To Report Fraud, Waste, and Abuse in Federal Programs

Contact:

Website: <http://www.gao.gov/fraudnet/fraudnet.htm>

E-mail: fraudnet@gao.gov

Automated answering system: (800) 424-5454 or (202) 512-7470

Congressional Relations

Katherine Siggerud, Managing Director, siggerudk@gao.gov, (202) 512-4400, U.S. Government Accountability Office, 441 G Street NW, Room 7125, Washington, DC 20548

Public Affairs

Chuck Young, Managing Director, youngc1@gao.gov, (202) 512-4800 U.S. Government Accountability Office, 441 G Street NW, Room 7149 Washington, DC 20548

