

Infiltrator IM- and TW-Series Septic Tank General Installation Instructions

MARCH 2014



BEFORE YOU BEGIN

Infiltrator Systems' tanks must be installed according to state and/or local regulations, which supersede the manufacturer's installation instructions. If unsure of the installation requirements for a specific site, contact the health department or permitting authority. The IM-Series referred to in this document includes the IM-540, IM-1060, and IM-1530 tanks. The TW-Series includes the TW-1250 and TW-1500 tanks.

WARNING: IMPLOSIONS MAY CAUSE SERIOUS INJURY
Follow Infiltrator Systems Inc. vacuum test instructions

MATERIALS AND EQUIPMENT NEEDED

- | | |
|--|--|
| <input type="checkbox"/> Infiltrator tank | <input type="checkbox"/> Shovel |
| <input type="checkbox"/> Access port lid(s)* | <input type="checkbox"/> Level |
| <input type="checkbox"/> 10 screws per lid* | <input type="checkbox"/> 5-inch-diameter (125 mm) hole saw (IM-Series only) |
| <input type="checkbox"/> 2 inlet/outlet gaskets (included) | <input type="checkbox"/> 5.25-inch-diameter (133 mm) hole saw (TW-Series only) |
| <input type="checkbox"/> Inlet/outlet tees* | <input type="checkbox"/> Utility knife |
| <input type="checkbox"/> Tape measure | <input type="checkbox"/> PVC pipe glue with primer |
| <input type="checkbox"/> Pipe, risers, etc. | |
| <input type="checkbox"/> Socket wrench | |
| <input type="checkbox"/> Excavator | |
- *tee and lid inclusion varies by state/province

INSTALLATION SITE SELECTION

- Do not install the tank in vehicular traffic areas. The tank is designed for non-traffic applications.
- The allowable soil cover depth is 6 to 48* inches (150 to 1,200 mm). *18-inch (450 mm) max. in Florida for Cat. 3 IM- and TW-Series tanks; 48-inch (1,200 mm) max. in Florida for Cat. 4 IM-Series tanks; 36-inch (900 mm) max. in Massachusetts, New Hampshire, North Carolina, and Oregon.
- The tank shall not be installed where the subsurface water level outside the tank exceeds the height of the outlet pipe saddle. Follow Table 4 guidelines.

EXCAVATING AND PREPARING THE SITE

- Unless buoyancy control measures are required, the excavation width and length should be 18 to 36 inches (450 to 900 mm) larger than the tank on each side or sized as necessary to ensure proper backfill compaction, as outlined in Steps 5-10 of "Backfilling the Tank" in this document. See Infiltrator IM- and TW-Series Tank Buoyancy Control Guidance document, available online at www.infiltratorsystems.com, for specific excavation requirements when installing buoyancy control measures.
- Excavation depth shall account for the height of tank (55 inches (1,375 mm) for the IM-Series tanks and 51 inches (1,275 mm) for the TW-Series tanks). Also account for 4 inches (100 mm) of bedding (if required) and cover depth (permissible cover depth is 0.5 to 4 feet (150 to 1,200 mm) of soil).
Note: If the water level outside the tank exceeds the height of the outlet pipe saddle, tank structural integrity may be compromised. Follow Table 4 guidelines.
- Inspect bottom of excavation to verify suitability of native soil for tank installation. Soils with large, protruding, or sharp stones or other similar objects that may damage the tank are not suitable.
- The tank may be installed either in suitable native soil (see Backfilling the Tank section) or a minimum 4-inch (100 mm) layer of well-graded granular soil having particles less than 3 inches (75 mm) in diameter, or maximum 0.5-inch (13 mm) diameter crushed stone.
- Create a uniform, compacted, level surface to ensure that the bottom of the tank is evenly supported. Verify that the installation surface is flat.

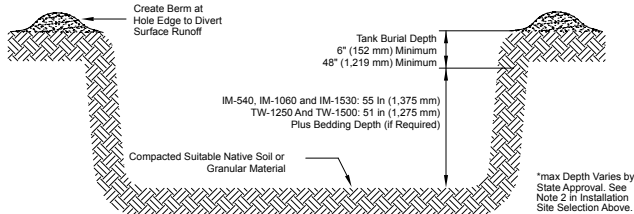

INSTALLING THE TANK

- Inspect the tank for damage before installation.
- If the tank inlet and outlet penetrations are not drilled, drill holes using the drill

points provided at each of the inlet and outlet ports according to the applicable Inlet and Outlet Hole Locations section of this document. The inlet and outlet may be drilled on either the sides or ends of the tank, as required based on applicable codes and site conditions.*

* Indiana, Kentucky, Oregon, West Virginia, and certain Florida and Texas tanks are factory-drilled.

- The gaskets supplied with the tank are compatible with Schedule 40 and SDR 35 pipe using a 5-inch-diameter (125 mm) hole saw with IM-Series tanks, and a 5¼-inch-diameter (133 mm) hole saw with TW-Series tanks.
- Install the rubber gaskets at the inlet and outlet.
- Using all four of the tank's integral lifting lugs, lower tank into excavation.
- Slide the inlet and outlet pipes* through the gaskets. Soapy lubricant may be used to slide the pipe in.
*For North Carolina, the inlet pipe shall be a straight pipe with no tee.
- Horizontally position the tee 1½ inches (40 mm) from the access port rim, allowing the tee to fit into the recess in the access port lid (see detail).
- Install lids and risers (see Installing Risers section) as necessary. Rotate lid over access opening until it indexes to tank and drops into position.

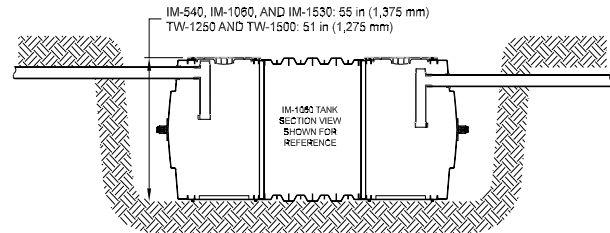
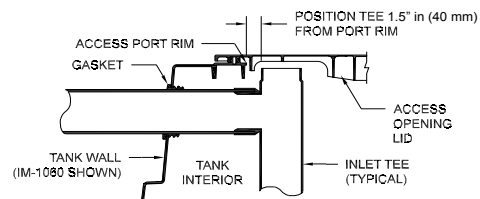

BACKFILLING THE TANK

Note: Infiltrator tanks do not require filling with water prior to backfill placement. Water filling and backfilling to the tank mid-height is required if the tank is left in either an open or backfilled excavation that may fill with water from rain or other sources.

- Backfill with suitable native soil (max. 3-inch (75-mm) stone diameter). If native soil is unsuitable, replace unsuitable fraction with suitable soil. If suitable soil is not locally available, contact Infiltrator Systems for assistance.
- Suitable soil shall include soil textural classes defined in the United States Department of Agriculture soil triangle. Suitable soil textural classes are based on the tank installation depth, as measured from finished grade to the top of tank.
 - For a tank soil cover depth of 0.5 to 2.0 feet (150 to 600 mm), suitable soil textures include:

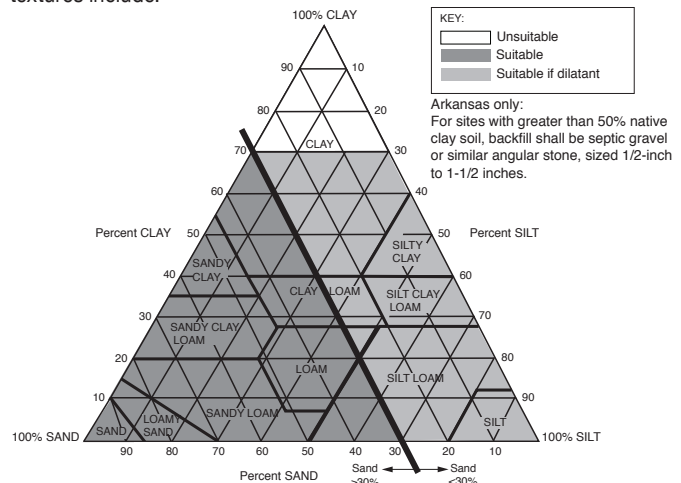

- b) For a tank soil cover depth that is greater than 2.0 feet and up to 4.0 feet (600 to 1,200 mm), suitable soil textures include:

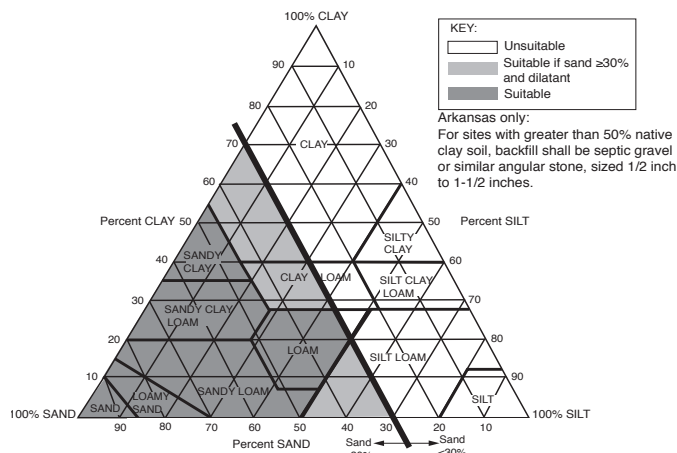

- Backfill should not have stones greater than 3 inches (75 mm) in diameter or excessive clods that do not break apart during placement and compaction. Backfill must be capable of occupying the spaces between the tank ribs and beneath the haunches.

Note: Rounded screened aggregate (e.g., pea gravel) is not a suitable backfill.
- Standard field soil classification methods shall be used to determine the soil textural class.

Note: Under most circumstances, the determination of soil dilatancy will not be required. Dilatancy shall be determined in the field using a test that does not require specialized equipment, per ASTM D2488, Section 14.3. Complete instructions can be found at www.infiltratorsystems.com
- Place and compact soil by walking-in beneath the haunches of the tank.
- Place backfill around the four sidewalls in an alternating manner, so that the backfill height along the four sidewalls is maintained within a 12-inch (300-mm) tolerance.
- Do not backfill top of tank before sidewalls are completely backfilled.
- Continue to place backfill along the sidewalls in 12-inch (300-mm) lifts. Place backfill between the ribs on the sidewalls such that the space between the ribs is completely filled with soil.
- Compact backfill material either by walking-in, hand tamping or mechanical compaction (includes backhoe bucket). If mechanical compaction is used, such as a walk-behind tamper or backhoe bucket, a single pass is recommended. Compact each lift prior to placement of next lift. Compact backfill from tank walls to excavation sidewalls.
- Complete backfilling and grade the area.
- A minimum 6-inch (150-mm) depth of suitable soil must be placed over the top of the tank. The balance of backfill placed to finish grade above the tank may be either suitable or unsuitable soil.
- Establish a strong stand of erosion-resistant vegetation.

Note: Grade to prevent the backfilled excavation from filling with surface runoff. If the water level in the backfilled excavation exceeds the height of the outlet pipe saddle, tank structural integrity may be compromised.

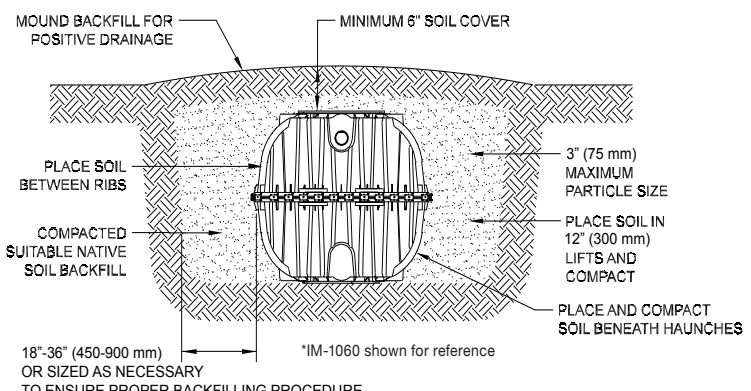

SHORT AND LONG-TERM GROUNDWATER CONTROL

It may be necessary to implement groundwater control measures during tank installation. Maintain dry conditions by expanding the excavation to create a short-term groundwater collection sump for temporary placement of a dewatering pump

if needed. Long-term groundwater control measures such as underdrains and interceptor trenches may be sensible if the site is amenable to construction of a control system and such systems are not prohibited by regulation or law, and the tank location is not subject to flooding. Properly installed underdrains and groundwater interceptor trenches may prevent the need for tank buoyancy control measures.

INSTALLING UNDER SHALLOW GROUNDWATER CONDITIONS

Buoyancy control measures may be required if the Infiltrator tank is to be installed with less than 12 inches (300 mm) of soil backfill cover, and where the water level outside the tank has the potential to rise 30 inches (750 mm) or more above the elevation of the tank bottom. Otherwise, no control measures are required (see Table 1). The need for buoyancy control measures must be determined based on backfill cover depth and height of water outside of tank above the tank bottom according to Table 1. Refer to Infiltrator IM- and TW-Series Tank Buoyancy Control Guidance document for more information.

Table 1: Tank models¹ and conditions requiring buoyancy control²

| Water height above tank bottom | Soil cover depth above tank ³ | |
|---|--|----------------------|
| | 6 in (150 mm) to 12 in (300 mm) | Above 12 in (300 mm) |
| Above outlet pipe saddle | Do not install | Do not install |
| 36 in (900 mm) to outlet pipe saddle ⁴ | All models | None |
| 30 in (750 mm) to 36 in (900 mm) | All models except IM-540 and IM-1060 | None |
| Less than 30 in (750 mm) | None | None |

- IM-540, IM-1060, TW-1250, TW-1500, and IM-1530.
- See Infiltrator IM- and TW- Series Tank Buoyancy Control Guidance for detailed information on the use of controls.
- No controls are required for soil cover depths exceeding 12 in (300 mm).
- The tank shall not be installed where the water level outside the tank exceeds the height of the outlet pipe saddle. Follow Table 4 guidelines.

INSTALLING RISERS

- Compatible risers include 24-inch (600 mm) diameter products such as the Infiltrator TW-Riser, EZset by Infiltrator, PolyLok®, Inc., and Tuf-Tite® Corporation, in addition to 24-inch (600 mm) diameter corrugated HDPE and IPEX Ultra Rib® PVC pipe. Follow Infiltrator's IM- and TW-Series Tank Riser Connection Guidance.
- In Oregon only, watertightness testing shall include filling with water at least 2 inches above riser connection, with no more than 1 gallon leakage per 24 hours, per OAR 340-073-0025(3).

INSTALLING PUMPS AND RELATED EQUIPMENT

Pumps may be supported on a stable, level 16x16-inch (400x400-mm) platform positioned on the bottom of the tank. One 16x16-inch block or two 8x16-inch (200 -mm x 400-mm) side-by-side blocks may be used. Limit block height to account for pump height and liquid levels during pump cycles. Block(s) should be placed below an access opening and level upon the tank bottom. For two blocks, orient them perpendicular to ribs on the tank bottom, if present, for stability. Installation of products such as electrical conduit and wiring, pumps, water level control equipment, valves, siphon equipment, etc. shall be in accordance with the product manufacturer's instructions and compliant with applicable state or local rules and regulations. Appurtenances shall be fastened to the tank riser system and not the tank body or access opening rim. Where possible, appurtenances shall be installed to facilitate maintenance and repair access via the tank access openings.

Note: Prefabricated pump vaults may be installed.

GENERAL SPECIFICATIONS

- Failure to comply with installation instructions will void warranty.
- Prior to ground disturbance, check for subsurface obstructions and utilities in conformance with applicable requirements.
- Operating water temperature shall be less than 100° F (40° C).
- In cold conditions, handle and backfill tank with care to prevent impact damage.
- Tanks are not fire resistant. Store away from ignition sources.
- Removal of structural bulkheads is prohibited; removal of locking clips on the IM-Series tank mid-seam connection is also prohibited.
- Only suitable for potable applications if the tank bears the NSF/ANSI 61 certification mark. Otherwise, tank is recommended for use in septic, rainwater/stormwater storage, holding, and pump applications, or other non-potable uses.
- Infiltrator tanks are designed for installation underground.
- Contact Infiltrator Systems for above-ground use requirements.

Table 2: Infiltrator Tank Nominal Volume Chart

| Height ¹ | | Total liquid volume in tank at indicated height | | | | | | | | | |
|---------------------|-----|---|--------|----------|--------|--------------------|--------|----------|--------|----------|--------|
| | | IM-540 | | IM-1060 | | IM-1530 | | TW-1250 | | TW-1500 | |
| in | cm | U.S. Gal | Liters | U.S. Gal | Liters | U.S. Gal | Liters | U.S. Gal | Liters | U.S. Gal | Liters |
| 1 | 3 | 3 | 11 | 3 | 11 | 17 | 64 | 14 | 53 | 17 | 64 |
| 2 | 5 | 8 | 30 | 13 | 49 | 34 | 128 | 30 | 115 | 37 | 140 |
| 3 | 8 | 14 | 53 | 28 | 106 | 51 | 192 | 58 | 218 | 71 | 267 |
| 4 | 10 | 21 | 80 | 46 | 174 | 68 | 256 | 87 | 330 | 107 | 404 |
| 5 | 13 | 29 | 109 | 65 | 246 | 94 | 357 | 117 | 444 | 143 | 543 |
| 6 | 15 | 37 | 141 | 86 | 326 | 122 | 463 | 148 | 558 | 180 | 683 |
| 7 | 18 | 46 | 173 | 107 | 405 | 152 | 573 | 178 | 674 | 218 | 825 |
| 8 | 20 | 55 | 207 | 129 | 488 | 180 | 681 | 209 | 791 | 256 | 968 |
| 9 | 23 | 64 | 243 | 152 | 575 | 212 | 802 | 240 | 910 | 294 | 1,112 |
| 10 | 25 | 74 | 279 | 176 | 666 | 245 | 928 | 272 | 1,029 | 332 | 1,257 |
| 11 | 28 | 84 | 317 | 200 | 757 | 280 | 1,061 | 304 | 1,149 | 371 | 1,404 |
| 12 | 30 | 94 | 356 | 225 | 852 | 312 | 1,182 | 336 | 1,270 | 410 | 1,551 |
| 13 | 33 | 105 | 396 | 251 | 950 | 351 | 1,328 | 368 | 1,393 | 449 | 1,700 |
| 14 | 36 | 116 | 437 | 277 | 1,049 | 387 | 1,463 | 400 | 1,516 | 489 | 1,849 |
| 15 | 38 | 127 | 480 | 303 | 1,147 | 422 | 1,597 | 433 | 1,640 | 528 | 2,000 |
| 16 | 40 | 138 | 523 | 330 | 1,249 | 464 | 1,756 | 466 | 1,765 | 569 | 2,152 |
| 17 | 43 | 150 | 566 | 357 | 1,351 | 500 | 1,892 | 500 | 1,892 | 609 | 2,305 |
| 18 | 46 | 161 | 611 | 384 | 1,454 | 537 | 2,034 | 533 | 2,019 | 650 | 2,459 |
| 19 | 48 | 173 | 656 | 411 | 1,556 | 575 | 2,177 | 567 | 2,146 | 690 | 2,614 |
| 20 | 50 | 186 | 702 | 438 | 1,658 | 614 | 2,322 | 601 | 2,275 | 732 | 2,769 |
| 21 | 53 | 198 | 749 | 465 | 1,760 | 652 | 2,468 | 636 | 2,407 | 774 | 2,928 |
| 22 | 56 | 210 | 796 | 493 | 1,866 | 690 | 2,612 | 671 | 2,541 | 816 | 3,091 |
| 23 | 58 | 223 | 843 | 521 | 1,972 | 729 | 2,758 | 708 | 2,678 | 860 | 3,256 |
| 24 | 61 | 235 | 891 | 549 | 2,078 | 770 | 2,914 | 745 | 2,819 | 905 | 3,425 |
| 25 | 64 | 248 | 940 | 577 | 2,184 | 808 | 3,058 | 781 | 2,955 | 948 | 3,589 |
| 26 | 66 | 261 | 988 | 605 | 2,290 | 847 | 3,208 | 815 | 3,086 | 990 | 3,747 |
| 27 | 69 | 274 | 1,038 | 633 | 2,396 | 887 | 3,356 | 849 | 3,215 | 1,031 | 3,903 |
| 28 | 71 | 287 | 1,088 | 662 | 2,506 | 928 | 3,513 | 883 | 3,342 | 1,072 | 4,057 |
| 29 | 74 | 300 | 1,137 | 691 | 2,616 | 968 | 3,665 | 916 | 3,469 | 1,112 | 4,210 |
| 30 | 76 | 313 | 1,185 | 719 | 2,722 | 1,007 | 3,814 | 950 | 3,594 | 1,152 | 4,362 |
| 31 | 79 | 326 | 1,233 | 747 | 2,828 | 1,048 | 3,966 | 982 | 3,719 | 1,192 | 4,514 |
| 32 | 81 | 338 | 1,281 | 775 | 2,934 | 1,087 | 4,113 | 1,015 | 3,842 | 1,232 | 4,663 |
| 33 | 84 | 351 | 1,328 | 802 | 3,036 | 1,126 | 4,262 | 1,047 | 3,964 | 1,271 | 4,810 |
| 34 | 86 | 363 | 1,375 | 830 | 3,142 | 1,165 | 4,410 | 1,079 | 4,084 | 1,309 | 4,956 |
| 35 | 89 | 375 | 1,421 | 857 | 3,244 | 1,204 | 4,557 | 1,110 | 4,203 | 1,347 | 5,101 |
| 36 | 91 | 387 | 1,466 | 884 | 3,346 | 1,242 | 4,701 | 1,141 | 4,320 | 1,385 | 5,243 |
| 37 | 94 | 399 | 1,511 | 911 | 3,449 | 1,280 | 4,846 | 1,172 | 4,436 | 1,422 | 5,384 |
| 38 | 97 | 411 | 1,555 | 938 | 3,551 | 1,318 | 4,988 | 1,201 | 4,548 | 1,458 | 5,521 |
| 39 | 99 | 422 | 1,598 | 965 | 3,653 | 1,355 | 5,131 | 1,230 | 4,657 | 1,494 | 5,654 |
| 40 | 102 | 433 | 1,640 | 992 | 3,755 | 1,393 | 5,272 | 1,261 | 4,772 | 1,532 | 5,798 |
| 41 | 104 | 444 | 1,681 | 1,018 | 3,854 | 1,430 | 5,412 | 1,286 | 4,869 | 1,562 | 5,915 |
| 42 | 107 | 455 | 1,722 | 1,044 | 3,952 | 1,466 | 5,550 | 1,314 | 4,972 | 1,596 | 6,042 |
| 43 | 109 | 465 | 1,761 | 1,069 | 4,047 | 1,502 | 5,685 | 1,340 | 5,074 | 1,629 | 6,167 |
| 44 | 112 | 475 | 1,799 | 1,094 | 4,141 | 1,537 | 5,817 | 1,366 | 5,172 | 1,661 | 6,288 |
| 45 | 114 | 485 | 1,836 | 1,118 | 4,232 | 1,572 | 5,950 | 1,390 | 5,263 | 1,690 | 6,399 |
| 46 | 117 | 494 | 1,871 | 1,142 | 4,323 | 1,604 | 6,070 | 1,410 | 5,337 | 1,715 | 6,492 |
| 47 | 119 | 503 | 1,905 | 1,165 | 4,410 | 1,638 | 6,201 | 1,427 | 5,402 | 1,737 | 6,574 |
| 48 | 122 | 512 | 1,938 | 1,187 | 4,493 | 1,667 | 6,310 | 1,439 | 5,446 | 1,750 | 6,626 |
| 49 | 124 | 520 | 1,970 | 1,208 | 4,573 | 1,697 | 6,422 | 1,448 | 5,481 | 1,762 | 6,669 |
| 50 | 127 | 528 | 1,999 | 1,228 | 4,648 | 1,724 | 6,527 | - | - | - | - |
| 51 | 130 | 535 | 2,027 | 1,247 | 4,720 | 1,749 | 6,621 | - | - | - | - |
| 52 | 132 | 542 | 2,050 | 1,265 | 4,789 | 1,766 | 6,684 | - | - | - | - |
| 53 | 135 | 547 | 2,071 | 1,278 | 4,838 | 1,777 | 6,726 | - | - | - | - |
| 54 | 137 | 551 ² | 2,087 | 1,287 | 4,872 | 1,785 ² | 6,758 | - | - | - | - |

1. Height measured from lowermost inside surface at bottom of corrugation in tank.

2. The total capacity of the IM-540 tank is 552 gallons; the total capacity of the IM-1530 tank is 1,787 gallons.

INLET AND OUTLET HOLE LOCATIONS

Drill height marks are provided on all Infiltrator tank models to guide inlet and outlet hole drilling. A single drill height mark is provided at each end or side port on the IM-Series tanks (example illustrated below). Holes may be drilled at the end or side inlet and outlet locations, as allowed by state and/or local regulations. The drill height mark indicates the center

point location for the hole saw. The pilot drill bit on the hole saw should be positioned at the center of the drill height mark to align the hole saw properly. On the TW-Series tanks, marks "A" (lower) and "B" (upper) are located at the inlet end, while marks "C" (lower) and "D" (middle) are located at the outlet end. Table 3 provides drilling and invert information by regulatory jurisdiction for the installation of 4-inch- (100-mm-) diameter pipe.

Table 3: Inlet and Outlet Hole Locations^a

| Jurisdiction ¹ | Inlet Drill Location | Outlet Drill Location | Invert Drop (in) [mm] | Inlet Invert Height (in) [mm] | | Outlet Invert Height ² and Liquid Level (in) [mm] |
|--|----------------------|-----------------------|-----------------------|--|------------------------------------|--|
| | | | | Above Inside Bottom of Tank ² | Above Excavation Base ³ | |
| IM-540 and IM-1530 | | | | | | |
| All | All | All | 3.00 [76] | 47.00 [1,994] | 47.20 [1,199] | 44.00 [1,118] |
| IM-1060 | | | | | | |
| All | End | End | 3.00 [76] | 47.00 [1,994] | 47.20 [1,199] | 44.00 [1,118] |
| | Side | Side | 3.00 [76] | 47.50 [1,207] | 47.70 [1,212] | 44.50 [1,130] |
| | Side | End | 3.50 [89] | 47.50 [1,207] | 47.70 [1,212] | 44.00 [1,118] |
| | End | Side | 2.50 [64] | 47.00 [1,994] | 47.20 [1,199] | 44.50 [1,130] |
| TW-1250 and TW-1500 | | | | | | |
| FL | B | D | 2.75 [70] | 42.75 [1,086] | 43.45 [1,102] | 40.00 [1,016] |
| DE, IA, MA, ON | A | D | 2.00 [51] | 42.00 [1,067] | 42.70 [1,086] | 40.00 [1,016] |
| AR, CA, CO, CT, ID, IN, KS, KY, MO, MT, ND, OR, PA, SD, TX, VT, WV | B | C | 3.00 [76] | 42.75 [1,086] | 43.45 [1,102] | 39.75 [1,010] |
| All Others | A | C | 2.25 [57] | 42.00 [1,067] | 42.70 [1,086] | 39.75 [1,010] |

1. Indiana, Kentucky, Oregon, West Virginia, and certain Florida and Texas tanks are factory drilled.
2. Invert heights are measured from the lowest interior surface at the bottom of the tank to the invert.
3. Invert heights are measured from the base of the excavation to the invert.
4. State, provincial, and local regulatory requirements supersede Table 3 information.

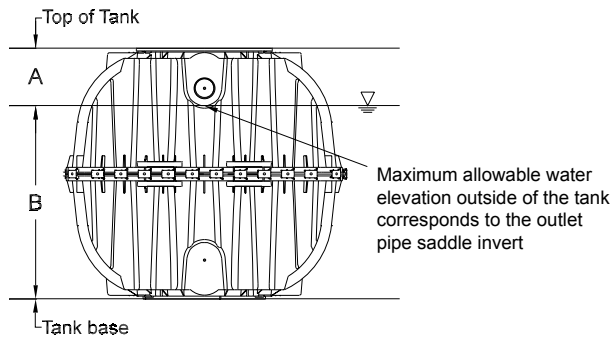

Table 4: Maximum Allowable Subsurface Water Elevation

| Tank Model | Vertical Distance to Maximum Allowable Water Elevation Outside of Tank | |
|------------------------|--|--------------------|
| | A - From Top of Tank | B - From Tank Base |
| IM-Series ¹ | 13" (330 mm) | 43" (1,075 mm) |
| TW-Series ² | 11" (280 mm) | 39" (975 mm) |

1. IM-Series tanks include the IM-540, IM-1060, and IM-1530.
2. TW-Series tanks include the TW-1250 and TW-1500.

INFILTRATOR SYSTEMS, INC. ("Infiltrator")

INFILTRATOR® SEPTIC TANK LIMITED WARRANTY

FIVE (5) YEAR MATERIALS AND WORKMANSHIP LIMITED WARRANTY

- This limited warranty is extended to the end user of an Infiltrator Septic Tank. A Septic Tank manufactured by Infiltrator, when installed and operated in accordance with Infiltrator's installation instructions and local regulation by a licensed installer, is warranted to you: (i) against defective materials and workmanship for five (5) years after installation. Infiltrator will, at its option, (i) repair the defective product or (ii) replace the defective materials. Infiltrator's liability specifically excludes the cost of removal and/or installation of the Septic Tank.
- In order to exercise its warranty rights, you must notify Infiltrator in writing at its corporate headquarters in Old Saybrook, Connecticut within fifteen (15) days of the alleged defect.
- YOUR EXCLUSIVE REMEDY WITH RESPECT TO ANY AND ALL LOSSES OR DAMAGES RESULTING FROM ANY CAUSE WHATSOEVER SHALL BE SPECIFIED IN SUBPARAGRAPH (a) ABOVE. INFILTRATOR SHALL IN NO EVENT BE LIABLE FOR ANY CONSEQUENTIAL OR INCIDENTAL DAMAGES OF ANY KIND, HOWEVER OCCASIONED, WHETHER BY NEGLIGENCE OR OTHERWISE. SOME STATES DO NOT ALLOW THE EXCLUSION OR LIMITATION OF INCIDENTAL OR CONSEQUENTIAL DAMAGES, SO THIS LIMITATION OR EXCLUSION MAY NOT APPLY TO YOU. THIS WARRANTY GIVES YOU SPECIFIC LEGAL RIGHTS AND YOU MAY ALSO HAVE OTHER RIGHTS WHICH VARY FROM STATE TO STATE.**
- THIS LIMITED WARRANTY IS THE EXCLUSIVE WARRANTY GIVEN BY INFILTRATOR AND SUPERSEDES ANY PRIOR, CONTRARY, ADDITIONAL, OR SUBSEQUENT REPRESENTATIONS, WHETHER ORAL OR WRITTEN. INFILTRATOR DISCLAIMS AND EXCLUDES TO THE GREATEST EXTENT ALLOWED BY LAW ALL OTHER WARRANTIES, WHETHER EXPRESS OR IMPLIED, OR STATUTORY, INCLUDING ANY WARRANTY OF MERCHANTABILITY, FINESSE FOR A PARTICULAR PURPOSE AND ANY IMPLIED WARRANTIES OTHERWISE ARISING FROM COURSE OF DEALING, COURSE OF PERFORMANCE, OR USAGE OF TRADE. NO PERSON (INCLUDING ANY EMPLOYEE, AGENT, DEALER, OR REPRESENTATIVE) IS AUTHORIZED TO MAKE ANY REPRESENTATION OR WARRANTY CONCERNING THIS PRODUCT, EXCEPT TO REFER YOU TO THIS LIMITED WARRANTY. EXCEPT AS EXPRESSLY SET FORTH HEREIN, THIS WARRANTY IS NOT A WARRANTY OF FUTURE PERFORMANCE, BUT ONLY A WARRANTY TO REPAIR OR REPLACE.**
- YOU MAY ASSIGN THIS LIMITED WARRANTY TO A SUBSEQUENT PURCHASER OF YOUR HOME.**
- NO REPRESENTATIVE OF INFILTRATOR HAS THE AUTHORITY TO CHANGE THIS LIMITED WARRANTY IN ANY MANNER WHATSOEVER, OR TO EXTEND THIS LIMITED WARRANTY.**

CONDITIONS AND EXCLUSIONS

There are certain conditions or applications over which Infiltrator has no control. Defects or problems as a result of such conditions or applications are not the responsibility of Infiltrator and are NOT covered under this warranty. They include failure to install the Septic Tank in accordance with instructions or applicable regulatory requirements or guidance, altering the Septic Tank contrary to the installation instructions and disposing of chemicals or other materials contrary to normal septic tank usage.

The above represents the Standard Limited Warranty offered by Infiltrator. A limited number of states and counties have different warranty requirements. Any purchaser of a Septic Tank should contact Infiltrator's corporate headquarters in Old Saybrook, Connecticut, prior to such purchase to obtain a copy of the applicable warranty, and should carefully read that warranty prior to the purchase of a Septic Tank.

Distributed By:



4 Business Park Road
P.O. Box 768
Old Saybrook, CT 06475
860-577-7000 • Fax 860-577-7001
1-800-221-4436
www.infiltratorsystems.com