



Final Report: Community Clean Energy Resiliency Initiative

February 18, 2015

**The Commonwealth of Massachusetts
Department of Energy Resources
100 Cambridge Street, Suite 100
Boston, MA 02451**

The Cadmus Group, Inc.

An Employee-Owned Company • www.cadmusgroup.com

Prepared by:
Dave Beavers
Danielle Burns
Charlie McClelland
Ryan Fahey

Table of Contents

Introduction	1
Technical Assistance Services	2
CCERI Funding Application Requirements.....	2
Awardee Metrics	2
Technical Assistance Overview.....	3
Key Questions Addressed	7
What Distributed Generation and Storage Technology Should Be Used?.....	7
Modeling and Information Gathering Constraints	7
What Benefits Will a Microgrid Provide?	8
What Ownership Structure Should Be Used?	9
How Much Is The Project Likely To Cost?.....	9
What Regulatory Challenges Could a Project Face?.....	9
Recommendations for Supporting Community Energy Resilience	10
Increase Number of Educational Offerings	10
Conduct Market Assessment of Energy Storage Technologies	11
Develop Guidance for Energy Resiliency Procurement.....	10
Identify a Clear Grid Interconnection Pathway for Energy Storage	11
Develop Tools to Identify Best Candidates for Resiliency Measures	11
Include a Site Visit as Part of the Technical Assistance Process.....	Error! Bookmark not defined.

Introduction

As part of the Massachusetts Administration's Climate Change Preparedness Initiatives, the governor of Massachusetts directed the Massachusetts Department of Energy Resources (DOER) to administer a \$40 million grant program to ensure energy resiliency at critical facilities in municipalities using clean energy technology. Energy resiliency is intended to reduce power service interruptions and support critical infrastructure during outages.

The Community Clean Energy Resiliency Initiative (CCERI or the Initiative) recognizes that climate change-induced events impact the entire commonwealth and that communities are at the forefront of responding to such events.

DOER contracted Cadmus to provide support and technical assistance for its CCERI efforts, in conjunction with HOMER Energy and MCFA. Together, these firms are called the Cadmus team.

This report summarizes the services provided by the Cadmus team and provides an assessment of the opportunities and barriers for municipalities to implement energy resiliency measures, the lessons learned throughout the technical assistance process, and recommendations for next steps.

Technical Assistance Services

In support of the Initiative, the Cadmus team provided technical assistance to 27 communities (awardees) exploring the potential for energy resilient power systems at critical facilities. Awardees included single municipalities, neighboring/joint municipalities, public/private partnerships, and regional planning agencies (RPAs) that represented multiple communities. All 351 communities in Massachusetts were eligible to apply for CCERI technical assistance.¹

Awardee Metrics

Notable metrics related to the 27 awardees were:

- Awardees were scattered geographically throughout Massachusetts, representing 10 of the 14 counties in the commonwealth. The highest concentration of awardees were in Middlesex County.
- Awardees represented communities with a variety of socioeconomic backgrounds. For example, in one community, the median household income was only \$31,628.²
- Awardees also represented communities with various population sizes—from less than 1,900 residents (Leverett) to nearly 650,000 residents (Boston). The median population of awardees' communities was approximately 21,000 residents.³
- Only one awardee was a municipally-owned utility; the remaining 26 were served by an investor-owned utility.
- Only one awardee requested and justified autonomy greater than three days (Beverly Cache Site, seven days).
- Only two awardees (Boston and Northampton) had previously retained outside consulting services to explore energy resiliency in their communities.
- Thirteen awardees had already designed or installed distributed generation at one or more of the proposed sites, and they asked the Cadmus team to assess adding battery backup or energy storage to the existing or planned generation source.

CCERI Funding Application Requirements

- Submitted by a municipality, multiple municipalities working together, regional planning agency, or public-private-partnership
 - Project to serve a critical facility
 - Incorporate clean energy generation, storage, or energy management technologies
 - Provide, at minimum, three days of power in the event of a grid-outage (“autonomy”)
-

¹ For more information on the Initiative, including links to the solicitation, applicants, and project information, refer to <http://www.mass.gov/eea/energy-utilities-clean-tech/renewable-energy/resiliency-initiative.html>.

² U.S. Census Bureau. 2010. Accessed online: <http://factfinder.census.gov/faces/nav/jsf/pages/index.xhtml>.

³ Ibid.

Technical Assistance Overview

With a large number of awardees and a larger number of individual sites to consider, the Cadmus team found it critical to establish a streamlined process to efficiently and effectively communicate with all participating communities. In doing so, we could better understand the awardees’ desired outcomes from participation in the Initiative and could collaboratively devise a preliminary plan to achieve these outcomes.

The cornerstone of this streamlined process involved designating a dedicated point of contact from the Cadmus team for each awardee.

Table 1 presents the four main areas of technical assistance we provided—educational offerings, community engagement, site screening, and provisions for a detailed project plan.

Table 1. Technical Assistance Services Provided to Awardees

Technical Assistance	Services Provided by the Cadmus Team
Educational Offerings	Participated in a webinar introducing the technical assistance team and describing the scope of technical assistance services to be provided under the Initiative.
Community Engagement	<p>Designated a single point of contact for each awardee. These points of contact gave awardees an overview of the technical assistance process, managed the data gathering process, kept in contact for day-to-day updates on project plan status and questions pertaining to the technical assistance process, communicated additional data-gathering needs of the modeling team, communicated deliverables timelines, and explained technical detail of the reports.</p> <p>The Cadmus team also held phone meetings with community stakeholders (including energy board, planners, facilities managers, utility representatives, and external consultants) to gather building energy usage data, understand the needs and concerns of the community, and assist in the prioritization of facilities for analysis.</p>
Site Screening for Distributed Generation and Energy Storage Potential	Provided site desktop screening for solar photovoltaic (e.g., rooftop, carport, and ground-mounted) and wind implementation potential. Also used Spark spread analysis to determine preliminary feasibility of using combined heat and power (CHP) systems.*
Detailed Project Plan	<p>For each project considered, developed a detailed project plan. The Cadmus team produced a total of 47 unique project plans on behalf of 27 awardees; plans were delivered during October 2014.</p> <p>Each project plan included an analysis of a single facility, or cluster of critical facilities, representing a broad array of services integral to communities during both normal (i.e., business as usual) and emergency response scenarios. The project plans enabled awardees to evaluate options for clean energy resiliency systems and prepared the community to apply for Phase 2 Implementation funding under the Initiative.**</p> <p>Project plans also outlined the technical and economic first-pass feasibility assessments of proposed projects. Project plans comprise a summary document listing key metrics and system characteristics, a system performance report, and additional information to support applicants’ efforts to apply for implementation assistance.</p>

Technical Assistance	Services Provided by the Cadmus Team
	<p>Each project plan contained the following elements:</p> <ul style="list-style-type: none"> • Summary of information gathered during the technical assistance process • Recommended system configurations for meeting the community’s energy resiliency needs • Overview of cost and energy performance factors for each proposed systems • Any other factors discovered during the investigation that might affect the feasibility of an energy resiliency project at the facility • Detailed results of the HOMER system optimization model • Additional information regarding battery technologies and interconnection costs.*** <p>Cadmus offered awardees the opportunity to schedule a project wrap-up call to discuss results in further detail; about half of the communities took this opportunity.</p>

* The term “spark spread” represents the gross margin of producing electricity from a gas-fired power plant versus the purchase price of electricity from the grid.

** A zip file containing all project plans delivered under the program can be found at: <http://www.mass.gov/eea/docs/doer/renewables/community-clean-energy-resiliency-initiative-technical-assistancereports-project-plans-and-appendices.zip>.

*** More information regarding the HOMER model can be found at: www.homerenergy.com.

Once we received a technical assistance application from DOER (and prior to initiating contact with the awardee), we reviewed the awardee’s description of the proposed sites to understand the potential opportunities and determine if any additional data or information were necessary, such as information regarding electrical services or specifications of existing fossil fuel generators (gensets) at the facility.

The dedicated point of contact also communicated with the awardee to introduce him/herself, explain the technical assistance process, and confirm our understanding of their technical assistance application. In some instances, awardees proposed energy resiliency projects at more facilities than the grant would allow for, so we helped the awardees prioritize which sites to pursue. For example, the City of Medford initially proposed seven disparate facilities with a range of technology options; we worked closely with city officials to identify three sites for technical assistance.

Following a high-level review of potential energy resilient technology options at each site, we sent an information request to the awardees. Following receipt of their responses, we scheduled a conference call with each awardee to discuss our initial approach and better understand site-specific circumstances, any challenges to pursuing a certain technology, or if groundwork had already been completed that should be used in our modeling. For example, the City of Cambridge was interested in pursuing a solar PV and battery storage system at its water treatment facility. The city had already completed a solar feasibility study at the site, and we were able to use the findings of that study to more accurately estimate the solar potential at the facility.

When suggesting potential energy resiliency technologies for awardees, we also considered the possibility of linking certain technologies together, thereby creating resilient hybrid systems. Many facilities included a hybrid of solar PV, battery storage, and existing fossil fuel generator.

For example, the Mt. Tom communications tower in the City of Holyoke had a particularly unique hybrid system; the suggested energy resilient technology would combine a small solar PV system, small wind turbine, battery storage, and a diesel generator—resulting in our most fuel-diverse site under CCERI. Figure 1 shows two scenarios for the Mt. Tom communications tower.

Figure 1. Scenarios for Mt. Tom Communications Tower in Holyoke

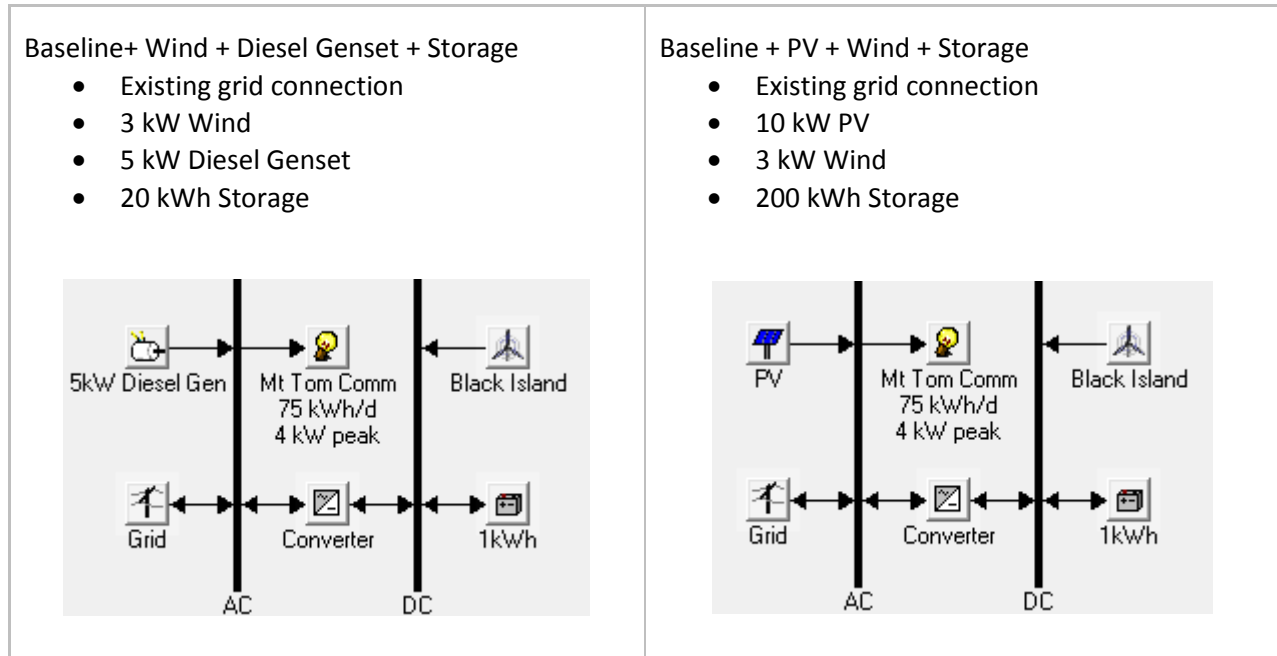

Using the awardee’s suggested sites and technologies, the responses of the information request, and information gathered during our discussions with the awardee, the Cadmus team developed models of proposed energy resilient technologies at the facility that represented three days of autonomous power from the electric grid.

We used HOMER Energy models, with which we could identify the optimal system size of the resilient technology and energy storage based on the facility’s prior energy usage and also estimate the costs for the technology and storage. We compiled these modeling results, as well as an explanation of the awardees’ facilities evaluated and assumptions we used, in a facility-specific project plan and delivered these to awardees.

The awardees used the results presented in the project plan to determine their interest in pursuing project implementation funding during Phase 2 of CCERI. As needed, the Cadmus team’s point of contact participated in a follow-up conversation with the awardee to discuss the findings in the project plan.

For example, we held a follow-up conference call with the Metropolitan Area Planning Council (MAPC) to explain the findings for the two municipal entities the council represented. Table 2 is an example of this technical assistance to MAPC for the Beverly Cache site.

Table 2. Municipal Technical Assistance Case Study

Technical Assistance Activity	Metropolitan Area Planning Council (MAPC) – Beverly Cache Site
Technical Assistance Application Review	The technical assistance application requested that the Cadmus team review solar PV, solar thermal, energy storage, and islanding mechanisms. Beverly Cache had no existing clean energy generation on site.
Confirmation of Sites and Technologies for Technical Assistance	The Beverly Cache site comprises a series of buildings; some are modular structures. We held a phone call with MAPC and the Beverly Cache site staff to determine which buildings were appropriate for solar PV. We also discovered during the call that no thermal load existed on the site and that wetlands were present in the area surrounding the buildings.
Request for Information	Our request for information included questions to determine the site’s electric feed capabilities and general energy usage. We also asked if MAPC and the Beverly Cache site staff would be interested in ground-mounted or parking canopy solar at the site.
Conference Call with Awardee	We held a follow-up call with MAPC and Beverly Cache site staff to discuss the proposed approach. All parties agreed to pursue ground-mounted and parking canopy solar PV in non-wetland areas of the site. Additionally, MAPC and Beverly Cache site staff requested that we evaluate autonomous power for a 7-day, rather than 3-day, outage.
Modeling and Project Plan	We conducted a desktop solar PV analysis to determine conservative solar PV potential based on available space. Using these estimates, we applied HOMER modeling to determine the appropriate battery storage sizing for a 7-day power outage. We prepared the project plan and sent it to MAPC and the Beverly Cache site staff.
Follow-Up on Project Plan	We held a brief follow-up call with MAPC to review the contents of the report.

Key Questions Addressed

In this section, Cadmus describes the questions addressed by the technical assistance services and the challenges and lessons learned throughout the technical assistance process.

What Distributed Generation and Storage Technology Should Be Used?

In general, the make-up of project sites, availability of Initiative budget, and site resource characteristics limited most potential system configurations to solar PV and battery storage as backup, CHP systems, or combinations of these technologies. We also considered the potential for biomass and small wind.

System Configuration Constraints

We ruled out CHP systems if there was an insufficient thermal load on the site. For example, we determined that CHP was infeasible at many schools that were not open year-round and that used air conditioning.

For solar PV and battery systems, we always recommended that a solar plus the storage system operate in conjunction with existing fossil fuel backup generators in order to boost the resiliency of the system and meet the target of three days of autonomous power.

In the scenario of solar PV coupled with the existing genset and batteries, the energy storage options were often cost-prohibitive. For example, we evaluated solar PV and battery backup for the Lawrence Wastewater Treatment Facility; because wastewater facilities have very high electric loads, battery storage to run this facility during a power outage was financially infeasible.

In trying to determine the best technology and configurations for each site, we also found there was:

- Limited opportunity for wind due to lack of resources and space, which is not surprising because the majority of facilities are occupied and located in densely populated areas.
- Limited potential for CHP implementation due to the absence of large, year-around thermal loads at most sites.
- Lack of information on small biomass systems. Although Western Massachusetts offers abundant biomass resources, the facilities considering this technology had relatively small loads. Details on source/cost information for smaller biomass systems (less than 100 kW) was not readily available.
- Cost-prohibitive battery scenarios. DOER requested that systems have three days of autonomy from the electric grid, which presents very expensive battery scenarios, even considering the availability of grant funding for implementation. We determined that accomplishing this

Modeling and Information Gathering Constraints

- Lack of understanding around building energy usage. (Load profile information generally not available.)
 - Lack of breakdown/ understanding of critical versus non-critical loads
 - Lack of thermal load necessary for CHP viability
-

autonomy with solar PV and battery alone was cost-prohibitive; the projected cost of the battery portion of the system alone would have been in excess of \$1 million for moderately sized facilities and much higher for larger facilities (e.g., schools or wastewater treatment plants). Providing a full three days of emergency power otherwise required the incorporation of fossil fuel gensets, often the lowest cost option, or CHP systems that present higher costs and require on-site thermal loads to qualify for state and utility incentives.

Technical Constraints

These technical constraints limited the potential for some sites:

- Reliability of wind and solar was a concern for certain facilities that require 24/7 operation (e.g., IT infrastructure). In general, we designed systems for winter storm months when solar resources would be low and, consequently, PV did not have a great effect on the size of battery needed for autonomy.
- At some facilities, emergency loads were simply too large to match with conventional generation and storage, such as at the Andover Wastewater Treatment Plant. Perhaps other technologies (e.g., bio-digesters) could offer solutions, though planning and execution of these systems was not practically achievable in allotted timeframe.
- Retrofitting existing solar systems with battery backup and islanding capabilities could be particularly challenging due to the need for air conditioner-coupled smart inverters. In many cases, complete replacement of the existing inverters could be necessary, which could present challenges if the existing system is under a Power Purchase Agreements (PPA) because it could violate the terms of the existing PPA.
- Lack of understanding, prior knowledge, or experience related to the impact of line-side interconnections and associated configuration on islanding operations. One utility said such a configuration (e.g., multiple interconnection pathways) would be possible, but it did not provide information concerning the level of detail needed for an interconnection study or the potential impact on system costs.
- No possible determination of the interaction between peak shaving and net-metering due to the lack of precedent. This made it difficult to estimate system and interconnection costs as well as any benefits and tradeoffs regarding the interaction between peak shaving and net-metering.

What Benefits Will a Microgrid Provide?

The Cadmus team received technical assistance applications from five awardees (Amherst, Boston, Melrose, Northampton, West Boylston) requesting an evaluation of a microgrid configuration. The geographic dispersion of the facilities to be included in the microgrid was the most limiting factor for the potential microgrids—primarily due to the high cost of conductors to interconnect the facilities. However, two of the awardees pursuing microgrids (Boston and Northampton) had already employed outside engineering services to evaluate the potential for a microgrid, and were confident in the benefits of a microgrid system.

What Ownership Structure Should Be Used?

The Cadmus team recommended that awardees consider using available grant funds to buy down the cost of a system lease. Further, we recommended they explore PPAs for new generation assets because this ownership structure is compatible with community needs. A PPA represents the “all-in” cost of energy (e.g., O&M costs are the responsibility of the third-party system owner). PPAs with performance guarantees, as required under Massachusetts General Law Chapter 25A, are particularly attractive due to the financial incentive for the system owner to maintain the project. Alternatively, customers pursuing direct ownership would be saddled with scheduling maintenance and sourcing vendors and would see these costs go directly against their bottom line/annual operating budget.

How Much Is The Project Likely To Cost?

One of the most frequent questions the awardees asked was, “How much will this system cost?” The Cadmus team encountered these distinct challenges when pricing the proposed systems:

- High uncertainty in microgrid development costs. We applied a microgrid development cost multiplier equal to 60% of the installed cost of the system. We obtained this 1.6 multiplier from a Sandia National Laboratories microgrid costing method outlined in the literature.⁴ However, the true application of this cost to microgrid configurations in Massachusetts is unknown.
- Operations and maintenance (O&M) were determined to be a major deterrent to energy resiliency; it is possible that O&M could be bundled into a lease and bought down with grant funding.

What Regulatory Challenges Could a Project Face?

There is not much experience with energy resiliency projects among the communities, utilities, and other potential participants in Massachusetts. Some of the challenges these projects could face are:

- Utility interconnection—there is very limited energy storage precedents in Massachusetts.
- Permitting process is difficult to capture due to high variability in municipal-level fire, building, and electrical requirements.
- Communities are also wary of liability concerns associated with hosting battery storage equipment, and the impact on insurance policies is not yet understood.

⁴ Jensen, R., et al. *Venetie, Alaska Energy Assessment*. Sandia National Laboratories. July 2013. Available online: <http://prod.sandia.gov/techlib/access-control.cgi/2013/136185.pdf>.

Recommendations for Supporting Community Energy Resilience

The communities receiving CCERI grants are among the first to pursue energy resiliency projects in Massachusetts. This was an opportunity for the CCERI awardees to learn about energy resiliency, uncover gaps in the community's knowledge, and shed light on the difficulties facing communities exploring clean energy resiliency projects.

After working with the communities and understanding their needs when approaching an energy resiliency project, Cadmus offers several recommendations for future iterations of the grant program and for DOER to consider in other initiatives related to resiliency:

- Increase number of education offerings
- Conduct market assessment of energy storage technologies, including case studies on existing projects to reduce uncertainty in system costing and development constraints
- Develop guidance for energy resiliency procurement
- Develop a clear pathway for energy storage parallel interconnection to the grid
- Structure application to identify best candidates for resiliency measures
- Include a site visit as part of the technical assistance process

Increase Number of Educational Offerings

To support the interpretation of project plan results, the Cadmus team provided additional information on battery technologies and interconnection considerations. DOER conducted three informational webinars in May 2014, in which it presented an overview of the Initiative, the technical assistance team and process, and project implementation grant.

To further bolster participation, early pre-screening of facilities, identification of viable distributed generation options, and management of expectations about O&M costs and storage concepts could be incorporated into program design. DOER could consider presenting a series of informational webinars to educate community energy leaders and champions. In this manner, DOER could support pre-screening of eligible facilities and improve the quality of technical assistance and project implementation applications.

Develop Guidance for Energy Resiliency Procurement

Many communities are procuring energy services through M.G.L. c. 25A 11C (contracts for procurement of energy management services) and 11I (Energy management services contracts; request for qualifications; regulations; payments; performance bond). DOER oversees these contract vehicles, which may also serve as a procurement vehicle for resiliency services. We recommend that DOER review the 25A procurement pathways to assess how they should be used by communities when procuring energy resiliency equipment or services and also advise these communities about best practices for doing so.

One issue that may arise is how to define “performance guarantee” in the context of energy resiliency services. Communities may benefit from a DOER-recommended definition of the term as it refers to energy resiliency, with suggestions for how it should be covered in contracts.

Identify a Clear Grid Interconnection Pathway for Energy Storage

The grid interconnection process for an energy resiliency project may be more complicated than for a distributed generation project. Currently power backup projects in Massachusetts do not operate in parallel with the grid. They operate only when the facility that they support is disconnected from the grid. Benefits from parallel operation of storage, in addition to energy resiliency, include the potential to reduce utility peak demand charges and sell ancillary services, such as support for grid voltage and frequency regulation, to the utility.

During the course of our work, we identified one project seeking parallel operation, but to our knowledge there is no clearly defined process for storage parallel operation. We recommend that DOER seek a clear interconnection pathway from the investor-owned utilities for energy resiliency projects, including when parallel operation may be considered; the impacts, if any, on net-metering status; and when engineering studies will be required; and how to achieve any additional benefits associated with a parallel interconnection. This clarification could help some communities avoid lengthy and costly interconnection processes.

Develop Tools to Identify Best Candidates for Resiliency Measures

With the exception of a few awardees, most communities did not have interval data on energy usage for their facilities, nor information on the facilities’ critical loads, as well as an understanding of the procurement pathway for energy resiliency projects. Easy to use tools that help communities conceptualize potential projects, and a first estimate of possible costs and benefits, would help communities screen out undesirable projects and focus attention on more feasible projects.

Conduct Market Assessment of Energy Storage Technologies

Cost data are sparse, and few vendors currently exist. Although energy storage, particularly lead-acid technologies, is well understood and has been used for backup power needs for decades, much speculation exists about:

- Permitting needs (building, electrical)
- Safety consideration and insurance requirements associated with energy storage applications
- Impacts on facility operating costs (O&M costs)
- Costs and benefits of competing technologies/battery chemistries (evaluating what other technologies are available, their cost, and the benefits they offer)
- Regulatory impacts (net metering, demand reduction, ancillary services including frequency regulation and Volt/VAR control)
- Cost to interconnect neighboring facilities into a microgrid

DOER could provide more guidance to potential applicants prior to the application process so potential applicants could self-select in or out of the technical assistance process based on key indicators. DOER could conduct a market study of energy storage technologies and present a series of case studies on existing projects to emphasize successes and challenges that would help communities planning similar projects reduce uncertainty about system costing and development of constraints.